

Model(s):
CERONA-36
CERONA-42

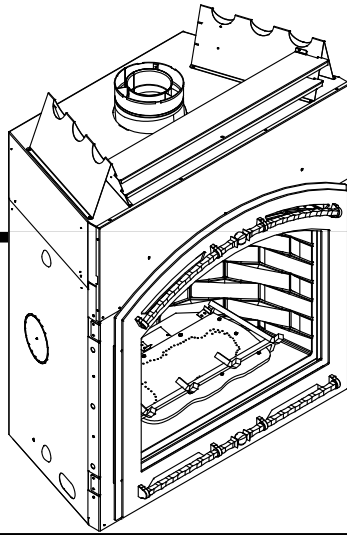

GAS-FIRED



NOTICE



DO NOT DISCARD THIS MANUAL

- Important operating and maintenance instructions included.
- Read, understand and follow these instructions for safe installation and operation.
- Leave this manual with party responsible for use and operation.

**DO NOT
DISCARD**

⚠ WARNING: If the information in these instructions is not followed exactly, a fire or explosion may result causing property damage, personal injury, or death.

- **DO NOT** store or use gasoline or other flammable vapors and liquids in the vicinity of this or any other appliance.
- **What to do if you smell gas**
 - **DO NOT** try to light any appliance.
 - **DO NOT** touch any electrical switch. **DO NOT** use any phone in your building.
 - Immediately call your gas supplier from a neighbor's phone. Follow the gas supplier's instructions.
 - If you cannot reach your gas supplier, call the fire department.
- Installation and service must be performed by a qualified installer, service agency, or the gas supplier.

In the Commonwealth of Massachusetts installation must be performed by a licensed plumber or gas fitter.

See Table of Contents for location of additional Commonwealth of Massachusetts requirements.



Installation and service of this appliance should be performed by qualified personnel. Hearth & Home Technologies suggests NFI certified or factory trained professionals, or technicians supervised by an NFI certified professional.

! WARNING



**HOT GLASS WILL CAUSE BURNS.
DO NOT TOUCH GLASS UNTIL COOLED.
NEVER ALLOW CHILDREN TO TOUCH GLASS.**

A barrier designed to reduce the risk of burns from the hot viewing glass is provided with this appliance and shall be installed.

This appliance may be installed as an OEM installation in manufactured home (USA only) or mobile home and must be installed in accordance with the manufacturer's instructions and the *Manufactured Home Construction and Safety Standard, Title 24 CFR, Part 3280* in the United States, or the *Standard for Installation in Mobile Homes, CAN/CSA Z240 MH Series*, in Canada.

This appliance is only for use with the type(s) of gas indicated on the rating plate. This appliance is not convertible for use with other gases, unless a certified kit is used.

Read this manual before installing or operating this appliance.
Please retain this owner's manual for future reference.

A. Congratulations

Congratulations on selecting a Heat & Glo gas fireplace, an elegant and clean alternative to wood burning fireplaces. The Heat & Glo gas fireplace you have selected is designed to provide the utmost in safety, reliability, and efficiency.

As the owner of a new fireplace, you'll want to read and carefully follow all of the instructions contained in this owner's manual. Pay special attention to all cautions and warnings.

This owner's manual should be retained for future reference. We suggest that you keep it with your other important documents and product manuals.

The information contained in this owner's manual, unless noted otherwise, applies to all models and gas control systems.

Your new Heat & Glo gas fireplace will give you years of durable use and trouble-free enjoyment. Welcome to the Heat & Glo family of fireplace products!

Homeowner Reference Information	<i>We recommend that you record the following pertinent information about your fireplace.</i>
Model Name: _____	Date purchased/installed: _____
Serial Number: _____	Location on fireplace: _____
Dealership purchased from: _____	Dealer Phone: _____
Notes: _____	

Listing Label Information/Location

The model information regarding your specific fireplace can be found on the rating plate usually located in the control area of the fireplace.



No one builds a better fire

Heat & Glo, a brand of Hearth & Home Technologies
7571 215th Street West, Lakeville, MN 55044

GAS-FIRED



Not for use with solid fuel.
(Ne doit pas être utilisé avec un combustible solide).

Type of Gas (*Sorte De Gaz*): **NATURAL GAS** This appliance must be installed in accordance with local codes, if any; if not, follow ANSI Z223.1 in the USA or CAN/CGA B149 installation codes. *(Installer l'appareil selon les codes ou règlements locaux ou, en l'absence de tels règlements, selon les codes d'installation CAN/CGA-B149.)*

ANSI Z21XX-XXXX · CSA 2.XX-MXX

Minimum Permissible Gas Supply for Purposes of Input Adjustment.

Approved Minimum (<i>De Gaz</i>) Acceptable	0.0 in w.c. (<i>Po. Col. d'eau</i>)
Maximum Pressure (<i>Pression</i>)	0.0 in w.c. (<i>Po. Col. d'eau</i>)
Maximum Manifold Pressure (<i>Pression</i>)	0.0 in w.c. (<i>Po. Col. d'eau</i>)
Minimum Manifold Pressure (<i>Pression</i>)	0.0 in w.c. (<i>Po. Col. d'eau</i>)

Total Electrical Requirements: 000Vac, 00Hz., less than 00 Amperes

MADE IN USA

ALTITUDE:	0-0000 FT. 0000-0000FT.	IN CANADA
MAX. INPUT BTUH:	00,000 00,000	
MIN. INPUT BTUH:	00,000 00,000	
ORIFICE SIZE:	#XXXXX #XXXXX	

Model:
(Modele): XXXXXXXX

Serial
(Serie): XXXXXXXX

Model Number

Serial Number

▲ Safety Alert Key:

- **DANGER!** Indicates a hazardous situation which, if not avoided will result in death or serious injury.
- **WARNING!** Indicates a hazardous situation which, if not avoided could result in death or serious injury.
- **CAUTION!** Indicates a hazardous situation which, if not avoided, could result in minor or moderate injury.
- **NOTICE:** Used to address practices not related to personal injury.

Table of Contents

A. Congratulations	2
B. Limited Lifetime Warranty	5

1 Listing and Code Approvals

A. Appliance Certification	7
B. Glass Specifications	7
C. BTU Specifications	7
D. High Altitude Installations	7
E. Non-Combustible Materials Specification	7
F. Combustible Materials Specification	7
G. Electrical Codes	7
H. Requirements for the Commonwealth of Massachusetts	8

User Guide

2 Operating Instructions

A. Gas Fireplace Safety	9
B. Your Fireplace	10
C. Fan Kit	10
D. Clear Space	10
E. Decorative Doors and Fronts	10
F. Fixed Glass Assembly	10
G. Remote Controls, Wall Controls and Wall Switches	10
H. Before Lighting Fireplace	10
I. Lighting Instructions (IPI)	11
J. After Fireplace is Lit	12
K. Frequently Asked Questions	12

3 Maintenance and Service

A. Maintenance Tasks-Homeowner	13
→ B. Maintenance Tasks-Qualified Service Technician	14

Installer Guide

4 Getting Started

A. Typical Appliance System	16
B. Design and Installation Considerations	17
C. Tools and Supplies Needed	17
D. Inspect Appliance and Components	17

5 Framing and Clearances

A. Selecting Appliance Location	18
B. Constructing the Appliance Chase	19
C. Clearances	19
D. Mantel and Wall Projections	20
E. Hearth Extension	21

6 Termination Locations

A. Vent Termination Minimum Clearances	22
--	----

7 Vent Information and Diagrams

A. Approved Pipe	24
B. Vent Table Key	24
C. Use of Elbows	24
D. Measuring Standards	24
E. Adding Vent Components	25
F. Install Support Brackets	25

8 Vent Clearances and Framing

A. Pipe Clearances to Combustibles	29
B. Wall Penetration Framing	29
C. Install the Ceiling Firestop	30
D. Install Attic Insulation Shield	30
E. Installing the Optional Heat-Zone® Gas Kit	31

9 Appliance Preparation

A. Removing Non-combustible Facing Material Assembly	32
B. Securing and Leveling the Appliance	32
C. Installing Non-combustible Facing Material	33
D. Installing Flue Restrictors	34

10 Installing Vent Pipe (DVP Pipe)

A. Assemble Vent Sections (DVP Pipe Only)	35
B. Assemble Slip Sections	36
C. Secure the Vent Sections	36
D. Disassemble Vent Sections	37
E. Install Decorative Ceiling Components	37
F. Install Metal Roof Flashing	38
G. Assemble and Install Storm Collar	38
H. Install Vertical Termination Cap	39
I. Heat Shield Requirements for Horizontal Termination	39
J. Install Horizontal Termination Cap	40

11 Gas Information

A. Fuel Conversion	41
B. Gas Pressure	41
C. Gas Connection	41
D. High Altitude Installations	41

12 Electrical Information

A. Wiring Requirements	42
B. Connecting to the Appliance	42
C. Intellifire Ignition System Wiring	42
D. Optional Accessories Requirements	42
E. Electrical Service and Repair	42

13 Finishing

A. Splatter Guard	44
B. Mantel Projections	45
C. Facing Material.	46
D. Finishing Material Options	47
E. Hearth Extension	48

14 Appliance Setup

A. Remove Fixed Glass Assembly	49
B. Remove the Shipping Materials	49
→ C. Inspect Firebox.	49
D. Clean the Appliance	49
E. Accessories	49
F. Ember Placement.	49
G. Positioning the Logs	50
H. Fixed Glass Assembly	54
I. Grilles and Trim	54
J. Air Shutter Setting	55
K. Install Mesh	55
L. Install Trim and/or Surround	55

15 Troubleshooting

A. Intellifire Ignition System	56
--	----

16 Reference Materials

A. Appliance Dimension Diagram.	58
B. Vent Components Diagrams	59
→ C. Service Parts	64
D. Contact Information	68

→ = Contains updated information.

B. Limited Lifetime Warranty

Hearth & Home Technologies LIMITED LIFETIME WARRANTY

Hearth & Home Technologies, on behalf of its hearth brands ("HHT"), extends the following warranty for HHT gas, wood, pellet, coal and electric hearth appliances that are purchased from an HHT authorized dealer.

WARRANTY COVERAGE:

HHT warrants to the original owner of the HHT appliance at the site of installation, and to any transferee taking ownership of the appliance at the site of installation within two years following the date of original purchase, that the HHT appliance will be free from defects in materials and workmanship at the time of manufacture. After installation, if covered components manufactured by HHT are found to be defective in materials or workmanship during the applicable warranty period, HHT will, at its option, repair or replace the covered components. HHT, at its own discretion, may fully discharge all of its obligations under such warranties by replacing the product itself or refunding the verified purchase price of the product itself. The maximum amount recoverable under this warranty is limited to the purchase price of the product. This warranty is subject to conditions, exclusions and limitations as described below.

WARRANTY PERIOD:

Warranty coverage begins on the date of original purchase. In the case of new home construction, warranty coverage begins on the date of first occupancy of the dwelling or six months after the sale of the product by an independent, authorized HHT dealer/ distributor, whichever occurs earlier. The warranty shall commence no later than 24 months following the date of product shipment from HHT, regardless of the installation or occupancy date. The warranty period for parts and labor for covered components is produced in the following table.

The term "Limited Lifetime" in the table below is defined as: 20 years from the beginning date of warranty coverage for gas appliances, and 10 years from the beginning date of warranty coverage for wood, pellet, and coal appliances. These time periods reflect the minimum expected useful lives of the designated components under normal operating conditions.

Warranty Period		HHT Manufactured Appliances and Venting							Components Covered
Parts	Labor	Gas	Wood	Pellet	EPA Wood	Coal	Electric	Venting	
1 Year		X	X	X	X	X	X	X	All parts and material except as covered by Conditions, Exclusions, and Limitations listed
2 years				X	X	X			Igniters, electronic components, and glass
		X	X	X	X	X			Factory-installed blowers
				X					Molded refractory panels
3 years				X					Firepots and burnpots
5 years	1 year			X	X				Castings and baffles
7 years	3 years		X	X	X				Manifold tubes, HHT chimney and termination
10 years	1 year	X							Burners, logs and refractory
Limited Lifetime	3 years	X	X	X	X	X			Firebox and heat exchanger
90 Days		X	X	X	X	X	X	X	All replacement parts beyond warranty period

See conditions, exclusions, and limitations on next page.

B. Limited Lifetime Warranty (*continued*)

WARRANTY CONDITIONS:

- This warranty only covers HHT appliances that are purchased through an HHT authorized dealer or distributor. A list of HHT authorized dealers is available on the HHT branded websites.
- This warranty is only valid while the HHT appliance remains at the site of original installation.
- This warranty is only valid in the country in which the HHT authorized dealer or distributor that sold the appliance resides.
- Contact your installing dealer for warranty service. If the installing dealer is unable to provide necessary parts, contact the nearest HHT authorized dealer or supplier. Additional service fees may apply if you are seeking warranty service from a dealer other than the dealer from whom you originally purchased the product.
- Check with your dealer in advance for any costs to you when arranging a warranty call. Travel and shipping charges for parts are not covered by this warranty.

WARRANTY EXCLUSIONS:

This warranty does not cover the following:

- Changes in surface finishes as a result of normal use. As a heating appliance, some changes in color of interior and exterior surface finishes may occur. This is not a flaw and is not covered under warranty.
- Damage to printed, plated, or enameled surfaces caused by fingerprints, accidents, misuse, scratches, melted items, or other external sources and residues left on the plated surfaces from the use of abrasive cleaners or polishes.
- Repair or replacement of parts that are subject to normal wear and tear during the warranty period. These parts include: paint, wood, pellet and coal gaskets, firebricks, grates, flame guides, batteries and the discoloration of glass.
- Minor expansion, contraction, or movement of certain parts causing noise. These conditions are normal and complaints related to this noise are not covered by this warranty.
- Damages resulting from: (1) failure to install, operate, or maintain the appliance in accordance with the installation instructions, operating instructions, and listing agent identification label furnished with the appliance; (2) failure to install the appliance in accordance with local building codes; (3) shipping or improper handling; (4) improper operation, abuse, misuse, continued operation with damaged, corroded or failed components, accident, or improperly/incorrectly performed repairs; (5) environmental conditions, inadequate ventilation, negative pressure, or drafting caused by tightly sealed constructions, insufficient make-up air supply, or handling devices such as exhaust fans or forced air furnaces or other such causes; (6) use of fuels other than those specified in the operating instructions; (7) installation or use of components not supplied with the appliance or any other components not expressly authorized and approved by HHT; (8) modification of the appliance not expressly authorized and approved by HHT in writing; and/or (9) interruptions or fluctuations of electrical power supply to the appliance.
- Non-HHT venting components, hearth components or other accessories used in conjunction with the appliance.
- Any part of a pre-existing fireplace system in which an insert or a decorative gas appliance is installed.
- HHT's obligation under this warranty does not extend to the appliance's capability to heat the desired space. Information is provided to assist the consumer and the dealer in selecting the proper appliance for the application. Consideration must be given to appliance location and configuration, environmental conditions, insulation and air tightness of the structure.

This warranty is void if:

- The appliance has been over-fired or operated in atmospheres contaminated by chlorine, fluorine, or other damaging chemicals. Over-firing can be identified by, but not limited to, warped plates or tubes, rust colored cast iron, bubbling, cracking and discoloration of steel or enamel finishes.
- The appliance is subjected to prolonged periods of dampness or condensation.
- There is any damage to the appliance or other components due to water or weather damage which is the result of, but not limited to, improper chimney or venting installation.

LIMITATIONS OF LIABILITY:

- The owner's exclusive remedy and HHT's sole obligation under this warranty, under any other warranty, express or implied, or in contract, tort or otherwise, shall be limited to replacement, repair, or refund, as specified above. In no event will HHT be liable for any incidental or consequential damages caused by defects in the appliance. Some states do not allow exclusions or limitation of incidental or consequential damages, so these limitations may not apply to you. This warranty gives you specific rights; you may also have other rights, which vary from state to state. EXCEPT TO THE EXTENT PROVIDED BY LAW, HHT MAKES NO EXPRESS WARRANTIES OTHER THAN THE WARRANTY SPECIFIED HEREIN. THE DURATION OF ANY IMPLIED WARRANTY IS LIMITED TO DURATION OF THE EXPRESSED WARRANTY SPECIFIED ABOVE.

1 Listing and Code Approvals

A. Appliance Certification

MODELS: CERONA-36, CERONA-42
LABORATORY: Underwriters Laboratories, Inc. (UL)
TYPE: Direct Vent Heater
STANDARD: ANSI Z21.88b-2005 • CSA2.33b-M2005 • UL307B

This product is listed to ANSI standards for “Vented Gas Fireplace Heaters” and applicable sections of “Gas Burning Heating Appliances for Manufactured Homes and Recreational Vehicles”, and “Gas Fired Appliances for Use at High Altitudes”.

NOTICE: This installation must conform with local codes. In the absence of local codes you must comply with the National Fuel Gas Code, ANSI Z223.1-latest edition in the U.S.A. and the CAN/CGA B149 Installation Codes in Canada.

NOT INTENDED FOR USE AS A PRIMARY HEAT SOURCE.
This appliance is tested and approved as either supplemental room heat or as a decorative appliance. It should not be factored as primary heat in residential heating calculations.

B. Glass Specifications

This appliance is equipped with 5 mm ceramic glass. Replace glass only with 5 mm ceramic glass. Please contact your dealer for replacement glass.

C. BTU Specifications

Model <i>(U.S. or Canada)</i>		Maximum Input BTU/h	Minimum Input BTU/h	Orifice Size (DMS)
Cerona-36 (NG)	US <i>(0-2000 FT)</i>	37,500	25,000	32
	CAN <i>(2000-4500 FT)</i>	33,750	22,300	33
Cerona-42 (NG)	US <i>(0-2000 FT)</i>	48,000	32,000	29
	CAN <i>(2000-4500 FT)</i>	40,500	28,800	30

D. High Altitude Installations

NOTICE: If the heating value of the gas has been reduced, these rules do not apply. Check with your local gas utility or authorities having jurisdiction.

When installing above 2000 feet elevation:

- In the USA: Reduce input rate 4% for each 1000 feet above 2000 feet.
- In CANADA: Reduce input rate 10% for elevations between 2000 feet and 4500 feet. Above 4500 feet, consult local gas utility.

Check with your local gas utility to determine proper orifice size.

E. Non-Combustible Materials Specification

Material which will not ignite and burn. Such materials are those consisting entirely of steel, iron, brick, tile, concrete, slate, glass or plasters, or any combination thereof.

Materials that are reported as passing **ASTM E 136, Standard Test Method for Behavior of Materials in a Vertical Tube Furnace at 750 °C** shall be considered non-combustible materials.

F. Combustible Materials Specification

Materials made of or surfaced with wood, compressed paper, plant fibers, plastics, or other material that can ignite and burn, whether flame proofed or not, or plastered or unplastered shall be considered combustible materials.

G. Electrical Codes

NOTICE: This appliance must be electrically wired and grounded in accordance with local codes or, in the absence of local codes, with **National Electric Code ANSI/NFPA 70-latest edition or the Canadian Electric Code CSA C22.1.**

- A 110-120 VAC circuit for this product must be protected with ground-fault circuit-interrupter protection, in compliance with the applicable electrical codes, when it is installed in locations such as in bathrooms or near sinks.

Note: The following requirements reference various Massachusetts and national codes not contained in this document.

H. Requirements for the Commonwealth of Massachusetts

For all side wall horizontally vented gas fueled equipment installed in every dwelling, building or structure used in whole or in part for residential purposes, including those owned or operated by the Commonwealth and where the side wall exhaust vent termination is less than seven (7) feet above finished grade in the area of the venting, including but not limited to decks and porches, the following requirements shall be satisfied:

Installation of Carbon Monoxide Detectors

At the time of installation of the side wall horizontal vented gas fueled equipment, the installing plumber or gas fitter shall observe that a hard wired carbon monoxide detector with an alarm and battery back-up is installed on the floor level where the gas equipment is to be installed. In addition, the installing plumber or gas fitter shall observe that a battery operated or hard wired carbon monoxide detector with an alarm is installed on each additional level of the dwelling, building or structure served by the side wall horizontal vented gas fueled equipment. It shall be the responsibility of the property owner to secure the services of qualified licensed professionals for the installation of hard wired carbon monoxide detectors.

In the event that the side wall horizontally vented gas fueled equipment is installed in a crawl space or an attic, the hard wired carbon monoxide detector with alarm and battery back-up may be installed on the next adjacent floor level.

In the event that the requirements of this subdivision can not be met at the time of completion of installation, the owner shall have a period of thirty (30) days to comply with the above requirements; provided, however, that during said thirty (30) day period, a battery operated carbon monoxide detector with an alarm shall be installed.

Approved Carbon Monoxide Detectors

Each carbon monoxide detector as required in accordance with the above provisions shall comply with NFPA 720 and be ANSI/UL 2034 listed and IAS certified.

Signage

A metal or plastic identification plate shall be permanently mounted to the exterior of the building at a minimum height of eight (8) feet above grade directly in line with the exhaust vent terminal for the horizontally vented gas fueled heating appliance or equipment. The sign shall read, in print size no less than one-half (1/2) in. in size, "**GAS VENT DIRECTLY BELOW. KEEP CLEAR OF ALL OBSTRUCTIONS**".

Inspection

The state or local gas inspector of the side wall horizontally vented gas fueled equipment shall not approve the installation unless, upon inspection, the inspector observes carbon monoxide detectors and signage installed in accordance with the provisions of 248 CMR 5.08(2)(a)1 through 4.

Exemptions

The following equipment is exempt from 248 CMR 5.08(2)(a)1 through 4:

- The equipment listed in Chapter 10 entitled "Equipment Not Required To Be Vented" in the most current edition of NFPA 54 as adopted by the Board; and
- Product Approved side wall horizontally vented gas fueled equipment installed in a room or structure separate from the dwelling, building or structure used in whole or in part for residential purposes.

MANUFACTURER REQUIREMENTS

Gas Equipment Venting System Provided

When the manufacturer of Product Approved side wall horizontally vented gas equipment provides a venting system design or venting system components with the equipment, the instructions provided by the manufacturer for installation of the equipment and the venting system shall include:

- Detailed instructions for the installation of the venting system design or the venting system components; and
- A complete parts list for the venting system design or venting system.

Gas Equipment Venting System NOT Provided

When the manufacturer of a Product Approved side wall horizontally vented gas fueled equipment does not provide the parts for venting the flue gases, but identifies "special venting systems", the following requirements shall be satisfied by the manufacturer:

- The referenced "special venting system" instructions shall be included with the appliance or equipment installation instructions; and
- The "special venting systems" shall be Product Approved by the Board, and the instructions for that system shall include a parts list and detailed installation instructions.

A copy of all installation instructions for all Product Approved side wall horizontally vented gas fueled equipment, all venting instructions, all parts lists for venting instructions, and/or all venting design instructions shall remain with the appliance or equipment at the completion of the installation.

See Gas Connection section for additional Commonwealth of Massachusetts requirements.

A. Gas Fireplace Safety

WARNING



**HOT GLASS WILL
CAUSE BURNS.
DO NOT TOUCH GLASS
UNTIL COOLED.
NEVER ALLOW CHILDREN
TO TOUCH GLASS.**

- Keep children away.
- CAREFULLY SUPERVISE children in same room as fireplace.
- Alert children and adults to hazards of high temperatures.

High temperatures may ignite clothing or other flammable materials.

- Clothing, furniture, draperies, and other flammable materials must not be placed on or near the appliance.

A barrier designed to reduce the risk of burns from the hot viewing glass is provided with this appliance and shall be installed. DO NOT operate the appliance with the barrier removed. If the barrier becomes damaged, the barrier shall be replaced with the manufacturer's barrier for this appliance.

Contact your dealer or Hearth & Home Technologies if the barrier is not present or help is needed to properly install one.

Young children should be carefully supervised when they are in the same room as the appliance. Toddlers, young children and others may be susceptible to accidental contact burns.

- A physical barrier is recommended if there are at risk individuals in the house.
- To restrict access to a fireplace or stove, install an adjustable safety gate to keep toddlers, young children and other at risk individuals out of the room and away from hot surfaces.
- Install a switch lock or a wall/remote control with child protection lockout feature.
- Keep remote controls out of reach of children.
- Never leave children alone near a hot fireplace, whether operating or cooling down.
- Teach children to NEVER touch the fireplace.
- Consider not using the fireplace when children will be present.

Contact your dealer for more information, or visit: www.hpba.org/safety-information.

To prevent unintended operation when not using your fireplace for an extended period of time (summer months, vacations, trips, etc):

- Remove batteries from remote controls.
- Turn off wall controls.
- Unplug 3 volt adapter plug and remove batteries on IPI models.

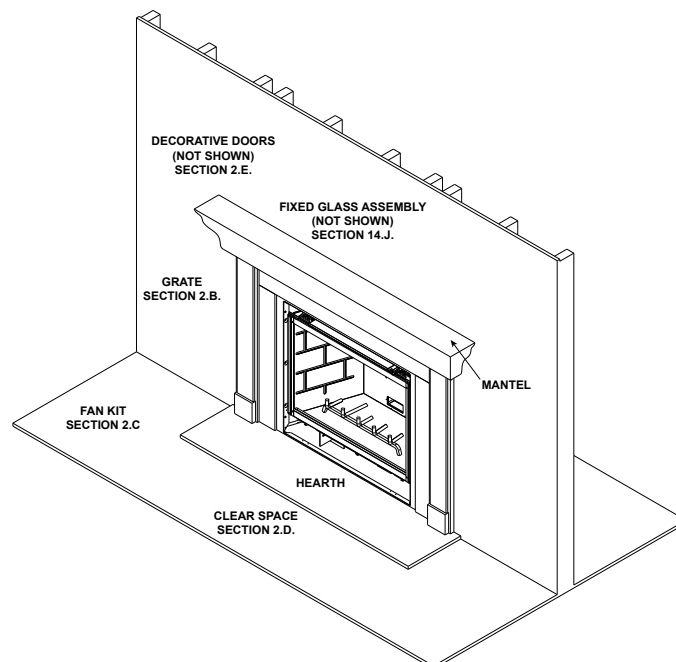

Figure 2.1 General Operating Parts

B. Your Fireplace

WARNING! DO NOT operate fireplace before reading and understanding operating instructions. Failure to operate fireplace according to operating instructions could cause fire or injury.

C. Fan Kit

A fan is shipped with this appliance.

D. Clear Space

WARNING! DO NOT place combustible objects in front of the fireplace or block louvers. High temperatures may start a fire. See Figure 2.2.

Avoid placing candles and other heat-sensitive objects on mantel or hearth. Heat may damage these objects.

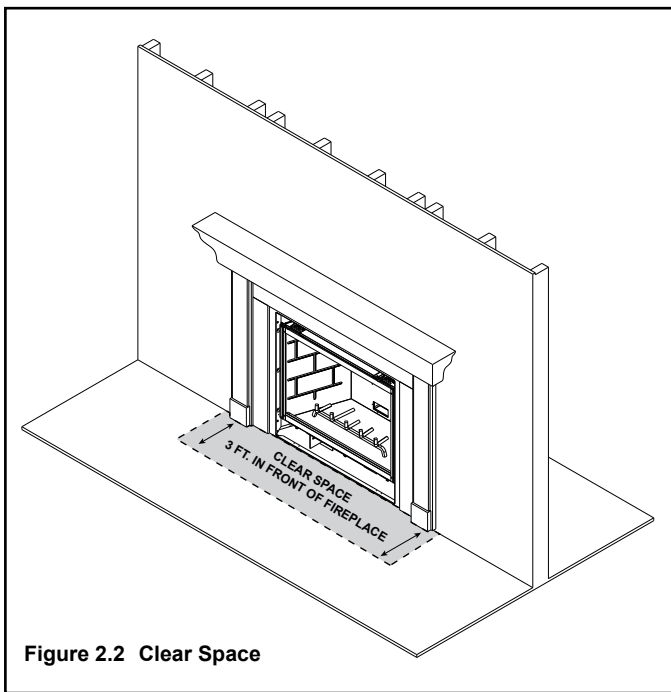

Figure 2.2 Clear Space

E. Decorative Doors and Fronts

WARNING! Risk of Fire! Install ONLY doors or fronts approved by Hearth & Home Technologies. Unapproved doors or fronts may cause fireplace to overheat.

This fireplace has been supplied with an integral barrier to prevent direct contact with the fixed glass panel. DO NOT operate the fireplace with the barrier removed.

Contact your dealer or Hearth & Home Technologies if the barrier is not present or help is needed to properly install one.

For more information refer to the instructions supplied with your decorative door or front.

F. Fixed Glass Assembly

See Section 14.G.

G. Remote Controls, Wall Controls and Wall Switches

Follow the instructions supplied with the control installed to operate your fireplace:

For safety:

- Install a switch lock or a wall/remote control with child protection lockout feature.
- Keep remote controls out of reach of children.

See your dealer if you have questions.

H. Before Lighting Fireplace

Before operating this fireplace for the first time, **have a qualified service technician:**

- Verify all shipping materials have been removed from inside and/or underneath the firebox.
- Review proper placement of logs, ember material and/or other decorative materials.
- Check the wiring.
- Check the air shutter adjustment.
- Ensure that there are no gas leaks.
- Ensure that the glass is sealed and in the proper position and that the integral barrier is in place.

WARNING! Risk of Fire or Asphyxiation! DO NOT operate fireplace with fixed glass assembly removed.

I. Lighting Instructions (IPI)

The IPI system may be operated with two D-cell batteries. When using batteries, unplug the transformer. To prolong battery life, remove them when using the transformer.

FOR YOUR SAFETY READ BEFORE LIGHTING

WARNING: If you do not follow these instructions exactly, a fire or explosion may result causing property damage, personal injury or loss of life.

- A.** This appliance is equipped with an intermittent pilot ignition (IPI) device which automatically lights the burner. **DO NOT** try to light the burner by hand.
- B. BEFORE LIGHTING,** smell all around the appliance area for gas. Be sure to smell next to the floor because some gas is heavier than air and will settle on the floor.
- WHAT TO DO IF YOU SMELL GAS**
- **DO NOT** try to light any appliance.
 - **DO NOT** touch any electric switch; do not use any phone in your building.
- Immediately call your gas supplier from a neighbor's phone. Follow the gas supplier's instructions.
 - If you cannot reach your gas supplier, call the fire department.
- C. DO NOT** use this appliance if any part has been under water. Immediately call a qualified service technician to inspect the appliance and to replace any part of the control system and any gas control which has been under water.

WARNING:

DO NOT CONNECT LINE VOLTAGE (110/120 VAC OR 220/240 VAC) TO THE CONTROL VALVE.

Improper installation, adjustment, alteration, service or maintenance can cause injury or property damage. Refer to the owner's information manual provided with this appliance.

This appliance needs fresh air for safe operation and must be installed so there are provisions for adequate combustion and ventilation air.

If not installed, operated, and maintained in accordance with the manufacturer's instructions, this product could expose you to substances in fuel or fuel combustion which are known to the State of California to cause cancer, birth defects, or other reproductive harm.

Keep burner and control compartment clean. See installation and operating instructions accompanying appliance.

For additional information on operating your
Hearth & Home Technologies fireplace, please refer to www.fireplaces.com.

CAUTION:

Hot while in operation. **DO NOT** touch. Keep children, clothing, furniture, gasoline and other liquids having flammable vapors away.

DO NOT operate the appliance with fixed glass assembly removed, cracked or broken. Replacement of the fixed glass assembly should be done by a licensed or qualified service person.

NOT FOR USE WITH SOLID FUEL

For use with natural gas and propane. A conversion kit, as supplied by the manufacturer, shall be used to convert this appliance to the alternate fuel.

Also Certified for Installation in a Bedroom or a Bedsitting Room.

For assistance or additional information, consult a qualified installer, service agency or the gas supplier.

LIGHTING INSTRUCTIONS (IPI)

1. This appliance is equipped with an ignition device which automatically lights the burner. **DO NOT** try to light the burner by hand.

**GAS
VALVE**

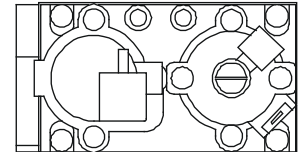

2. Wait five (5) minutes to clear out any gas. Then smell for gas, including near the floor. If you smell gas, STOP! Follow "B" in the Safety Information located on the left side of this label. If you do not smell gas, go to next step.
3. To light the burner:
Equipped with wall switch: Turn ON/OFF switch to ON.
Equipped with remote or wall control: Press ON or FLAME button.
Equipped with thermostat: Set temperature to desired setting.
4. If the appliance does not light after three tries, call your service technician or gas supplier.

TO TURN OFF GAS TO APPLIANCE

1. Equipped with wall switch: Turn ON/OFF switch to OFF.
Equipped with remote or wall control: Press OFF button.
Equipped with thermostat: Set temperature to lowest setting.
2. Service technician should turn off electric power to the control when performing service.

593-913G

Final inspection by _____

J. After Fireplace is Lit

Initial Break-in Procedure

- The fireplace should be run three to four hours continuously on high.
- Turn the fireplace off and allow it to completely cool.
- Remove fixed glass assembly. See Section 14.G.
- Clean fixed glass assembly. See Section 3.
- Replace the fixed glass assembly and run continuously on high an additional 12 hours.

This cures the materials used to manufacture the fireplace.

NOTICE! Open windows for air circulation during fireplace break-in.

- *Some people may be sensitive to smoke and odors.*
- *Smoke detectors may activate.*

K. Frequently Asked Questions

ISSUE	SOLUTIONS
Condensation on the glass	This is a result of gas combustion and temperature variations. As the fireplace warms, this condensation will disappear.
Blue flames	This is a result of normal operation and the flames will begin to yellow as the fireplace is allowed to burn for 20 to 40 minutes.
Odor from fireplace	When first operated, this fireplace may release an odor for the first several hours. This is caused by the curing of the paint and the burning off of any oils remaining from manufacturing. Odor may also be released from finishing materials and adhesives used around the fireplace.
Film on the glass	This is a normal result of the curing process of the paint and logs. Glass should be cleaned within 3 to 4 hours of initial burning to remove deposits left by oils from the manufacturing process. A non-abrasive cleaner such as gas fireplace glass cleaner may be necessary. See your dealer.
Metallic noise	Noise is caused by metal expanding and contracting as it heats up and cools down, similar to the sound produced by a furnace or heating duct. This noise does not affect the operation or longevity of the fireplace.
Is it normal to see the pilot flame burn continually?	In an intermittent pilot ignition system (IPI), the pilot flame should turn off when appliance is turned off. Some optional control systems available with IPI models may allow pilot flame to remain lit.

3 Maintenance and Service

Any safety screen or guard removed for servicing must be replaced prior to operating the fireplace.

When properly maintained, your fireplace will give you many years of trouble-free service. We recommend annual service by a qualified service technician.

A. Maintenance Tasks-Homeowner

Installation and repair should be done by a qualified service technician only. The fireplace should be inspected before use and at least annually by a professional service person.

The following tasks may be performed annually by the homeowner. If you are uncomfortable performing any of the listed tasks, please call your dealer for a service appointment.

More frequent cleaning may be required due to lint from carpeting or other factors. Control compartment, burner and circulating air passageway of the fireplace must be kept clean.

CAUTION! Risk of Burns! *The fireplace should be turned off and cooled before servicing.*

Glass Cleaning

Frequency: Seasonally

By: Homeowner

Tools Needed: Protective gloves, glass cleaner, drop cloth and a stable work surface.

CAUTION! Handle fixed glass assembly with care. *Glass is breakable.*

- *Avoid striking, scratching or slamming glass*
- *Avoid abrasive cleaners*
- **DO NOT** clean glass while it is hot
- Prepare a work area large enough to accommodate fixed glass assembly and door frame by placing a drop cloth on a flat, stable surface.

Note: Fixed glass assembly and gasketing may have residue that can stain carpeting or floor surfaces.

- Remove door or decorative front from fireplace and set aside on work surface.
- See Section 14.G for instructions to remove fixed glass assembly.
- Clean glass with a non-abrasive commercially available cleaner.
 - Light deposits: Use a soft cloth with soap and water
 - Heavy deposits: Use commercial fireplace glass cleaner (consult with your dealer)
- Carefully set fixed glass assembly in place on fireplace. Hold glass in place with one hand and secure glass latches with the other hand.
- Reinstall door or decorative front.

Doors, Surrounds, Fronts

Frequency: Annually

By: Homeowner

Tools needed: Protective gloves, stable work surface

- Assess condition of screen and replace as necessary.
- Inspect for scratches, dents or other damage and repair as necessary.
- Check that louvers are not blocked.
- Vacuum and dust surfaces.

Remote Control

Frequency: Seasonally

By: Homeowner

Tools needed: Replacement batteries and remote control instructions.

- Locate remote control transmitter and receiver.
- Verify operation of remote. Refer to remote control operation instructions for proper calibration and setup procedure.
- Place batteries as needed in remote transmitters and battery-powered receivers.
- Place remote control out of reach of children.

If not using your fireplace for an extended period of time (summer months, vacations/trips, etc), to prevent unintended operation:

- Remove batteries from remote controls.
- Unplug 3 volt adapter plug on IPI models.

Venting

Frequency: Seasonally

By: Homeowner

Tools needed: Protective gloves and safety glasses.

- Inspect venting and termination cap for blockage or obstruction such plants, bird nests, leaves, snow, debris, etc.
- Verify termination cap clearance to subsequent construction (building additions, decks, fences, or sheds). See Section 6.
- Inspect for corrosion or separation.
- Verify weather stripping, sealing and flashing remains intact.
- Inspect draft shield to verify it is not damaged or missing.

B. Maintenance Tasks-Qualified Service Technician

The following tasks must be performed by a qualified service technician.

Gasket Seal and Glass Assembly Inspection

Frequency: Annually

By: Qualified Service Technician

Tools needed: Protective gloves, drop cloth and a stable work surface.

- Inspect gasket seal and its condition.
- Inspect fixed glass assembly for scratches and nicks that can lead to breakage when exposed to heat.
- Confirm there is no damage to glass or glass frame. Replace as necessary.
- Verify that fixed glass assembly is properly retained and attachment components are intact and not damaged. Replace as necessary.

Logs

Frequency: Annually

By: Qualified Service Technician

Tools needed: Protective gloves.

- Inspect for damaged or missing logs. Replace as necessary. Refer to Section 14 for log placement instructions.
- Verify correct log placement and no flame impingement causing sooting. Correct as necessary.

Control Compartment and Firebox Top

Frequency: Annually

By: Qualified Service Technician

Tools needed: Protective gloves, vacuum cleaner, dust cloths

- Vacuum and wipe out dust, cobwebs, debris or pet hair. Use caution when cleaning these areas. Screw tips that have penetrated the sheet metal are sharp and should be avoided.
- Remove all foreign objects.
- Verify unobstructed air circulation.

Burner Ignition and Operation

Frequency: Annually

By: Qualified Service Technician

Tools needed: Protective gloves, vacuum cleaner, whisk broom, flashlight, voltmeter, indexed drill bit set, and a manometer.

- Verify burner is properly secured and aligned with pilot or igniter.
- Clean off burner top, inspect for plugged ports, corrosion or deterioration. Replace burner if necessary.
- Replace Glowing embers with new dime-size pieces. **DO NOT** block ports or obstruct lighting paths. Refer to Section 14 for proper ember placement.
- Verify batteries have been removed from battery back-up IPI systems to prevent premature battery failure or leaking.
- Check for smooth lighting and ignition carryover to all ports. Verify that there is no ignition delay.
- Inspect for lifting or other flame problems.
- Verify air shutter setting is correct. See Section 14 for required air shutter setting. Verify air shutter is clear of dust and debris.
- Inspect orifice for soot, dirt and corrosion. Verify orifice size is correct. See Service Parts List for proper orifice sizing.
- Verify manifold and inlet pressures. Adjust regulator as required.
- Inspect pilot flame pattern and strength. See Figure 3.1 for proper pilot flame pattern. Clean or replace orifice spud as necessary.
- Inspect IPI flame sensing rod for soot, corrosion and deterioration. Polish with fine steel wool or replace as required.
- Verify that there is not a short in flame sense circuit by checking continuity between pilot hood and flame sensing rod. Replace pilot as necessary.

Firebox



Frequency: Annually

By: Service Technician

Tools needed: Protective gloves, sandpaper, steel wool, cloths, mineral spirits, primer and touch-up paint.

- Inspect for paint condition, warped surfaces, corrosion or perforation. Sand and repaint as necessary.
- Replace appliance if firebox has been perforated.

Surface cracking or crazing of firebrick material is normal and expected. All cracks are acceptable and do not require replacement of the unit or the firebox with the exception of:

- Cracks compromising the surface plane of the firebox. See Figure 3.2.



Figure 3.1 IPI Pilot Flame Patterns

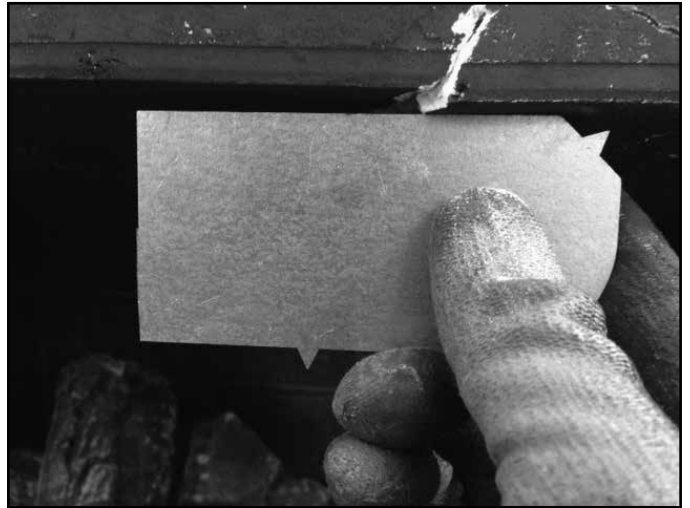

Figure 3.2. Surface plane of firebox is comprised and should be replaced.

4 Getting Started

Installer Guide

A. Typical Appliance System

NOTICE: Illustrations and photos reflect typical installations and are for design purposes only. Illustrations/diagrams are not drawn to scale. Actual product may vary from pictures in manual.

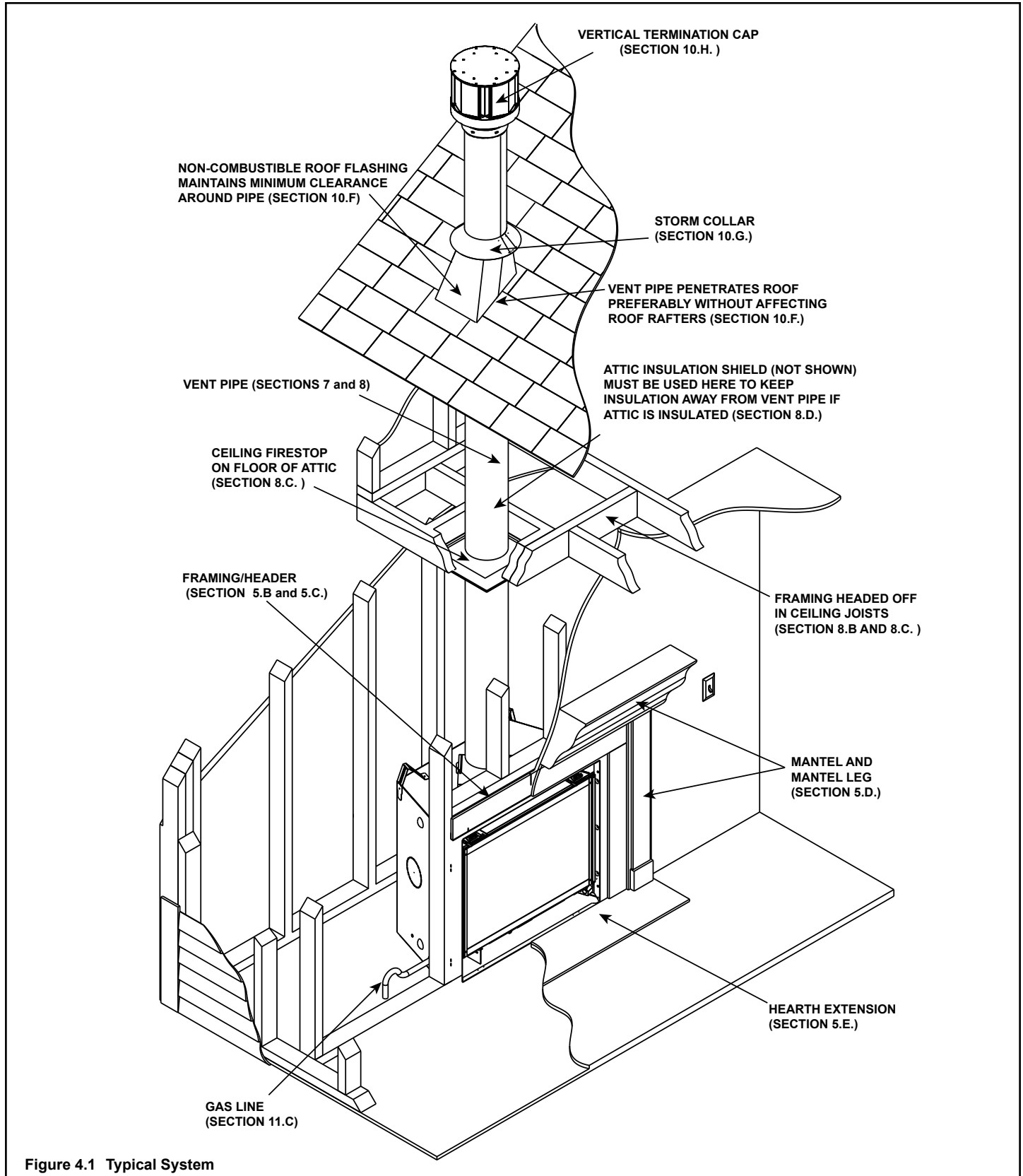

Figure 4.1 Typical System

B. Design and Installation Considerations

Heat & Glo direct vent gas appliances are designed to operate with all combustion air siphoned from outside of the building and all exhaust gases expelled to the outside. No additional outside air source is required.

Installation **MUST** comply with local, regional, state and national codes and regulations. Consult insurance carrier, local building inspector, fire officials or authorities having jurisdiction over restrictions, installation inspection and permits.

Before installing, determine the following:

- Where the appliance is to be installed.
- The vent system configuration to be used.
- Gas supply piping requirements.
- Electrical wiring requirements.
- Framing and finishing details.
- Whether optional accessories—devices such as a fan, wall switch, or remote control—are desired.

Improper installation, adjustment, alteration, service or maintenance can cause injury or property damage. For assistance or additional information, consult a qualified service technician, service agency or your dealer.

C. Tools and Supplies Needed

Before beginning the installation be sure that the following tools and building supplies are available.

- | | |
|----------------------|-----------------------------------|
| Tape measure | Framing material |
| Pliers | Hammer |
| Phillips screwdriver | Manometer |
| Gloves | Framing square |
| Voltmeter | Electric drill and bits (1/4 in.) |
| Plumb line | Safety glasses |
| Level | Reciprocating saw |
- Flat blade screwdriver
Non-corrosive leak check solution
1/2 - 3/4 in. length, #6 or #8 Self-drilling screws
Caulking material (300°F minimum continuous exposure rating)
One 1/4 in. female connection (for optional fan).

D. Inspect Appliance and Components

- Carefully remove the appliance and components from the packaging.
- The vent system components and decorative doors and fronts may be shipped in separate packages.
- If packaged separately, the log set and appliance grate must be installed.
- Report to your dealer any parts damaged in shipment, particularly the condition of the glass.
- **Read all of the instructions before starting the installation. Follow these instructions carefully during the installation to ensure maximum safety and benefit.**

WARNING! Risk of Fire or Explosion! Damaged parts could impair safe operation. DO NOT install damaged, incomplete or substitute components. Keep appliance dry.

Hearth & Home Technologies disclaims any responsibility for, and the warranty will be voided by, the following actions:

- Installation and use of any damaged appliance or vent system component.
- Modification of the appliance or vent system.
- Installation other than as instructed by Hearth & Home Technologies.
- Improper positioning of the gas logs or the glass door.
- Installation and/or use of any component part not approved by Hearth & Home Technologies.

Any such action may cause a fire hazard.

WARNING! Risk of Fire, Explosion or Electric Shock! DO NOT use this appliance if any part has been under water. Call a qualified service technician to inspect the appliance and to replace any part of the control system and/or gas control which has been under water.

5 Framing and Clearances

A. Selecting Appliance Location

When selecting a location for the appliance it is important to consider the required clearances to walls (see Figure 5.1).

WARNING! Risk of Fire or Burns! Provide adequate clearance around air openings and for service access. Due to high temperatures, the appliance should be located out of traffic and away from furniture and draperies.

NOTICE: Illustrations reflect typical installations and are FOR DESIGN PURPOSES ONLY. Illustrations/diagrams are not drawn to scale. Actual installation may vary due to individual design preference.

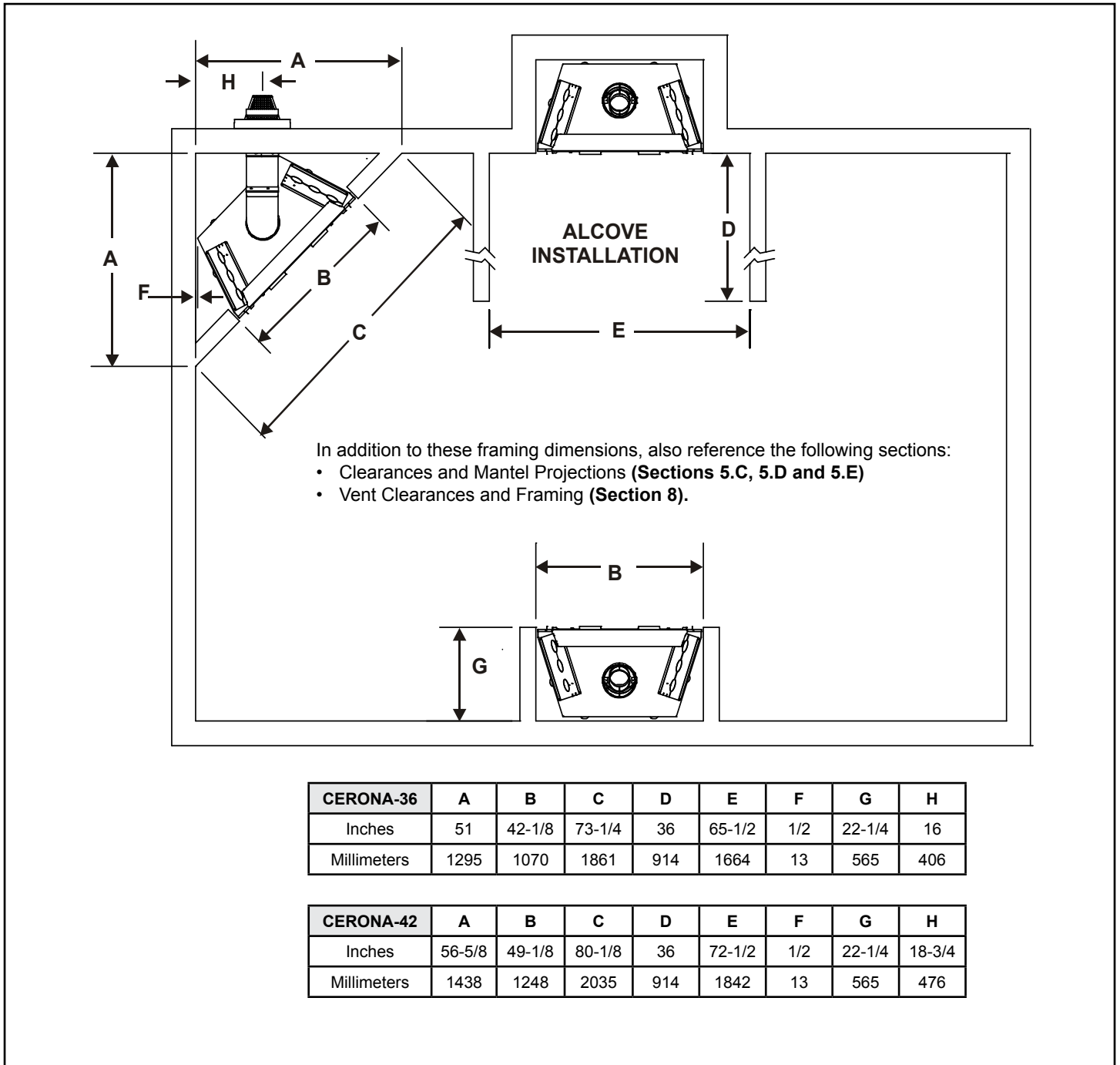

Figure 5.1 Appliance Locations

B. Constructing the Appliance Chase

A chase is a vertical box-like structure built to enclose the gas appliance and/or its vent system. In cooler climates the vent should be enclosed inside the chase.

NOTICE: Treatment of ceiling firestops and wall shield firestops and construction of the chase may vary with the type of building. These instructions are not substitutes for the requirements of local building codes. Therefore, you **MUST** check local building codes to determine the requirements to these steps.

Chases should be constructed in the manner of all outside walls of the home to prevent cold air drafting problems. The chase should not break the outside building envelope in any manner.

Walls, ceiling, base plate and cantilever floor of the chase should be insulated. Vapor and air infiltration barriers should be installed in the chase as per regional codes for the rest of the home. Additionally, in regions where cold air infiltration may be an issue, the inside surfaces may be sheetrocked and taped for maximum airtightness.

To further prevent drafts, the wall shield and ceiling firestops should be caulked with caulk with a minimum of

300°F continuous exposure rating to seal gaps. Gas line holes and other openings should be caulked with caulk with a minimum of 300°F continuous exposure rating or stuffed with unfaced insulation. If the appliance is being installed on a cement surface, a layer of plywood may be placed underneath to prevent conducting cold up into the room.

C. Clearances

NOTICE: Install appliance on hard metal or wood surfaces extending full width and depth. **DO NOT** install directly on carpeting, vinyl, tile or any combustible material other than wood.

WARNING! Risk of Fire! Maintain specified air space clearances to appliance and vent pipe:

- Insulation and other materials must be secured to prevent accidental contact.
- The chase must be properly blocked to prevent blown insulation or other combustibles from entering and making contact with fireplace or chimney.
- Failure to maintain airspace may cause overheating and a fire.

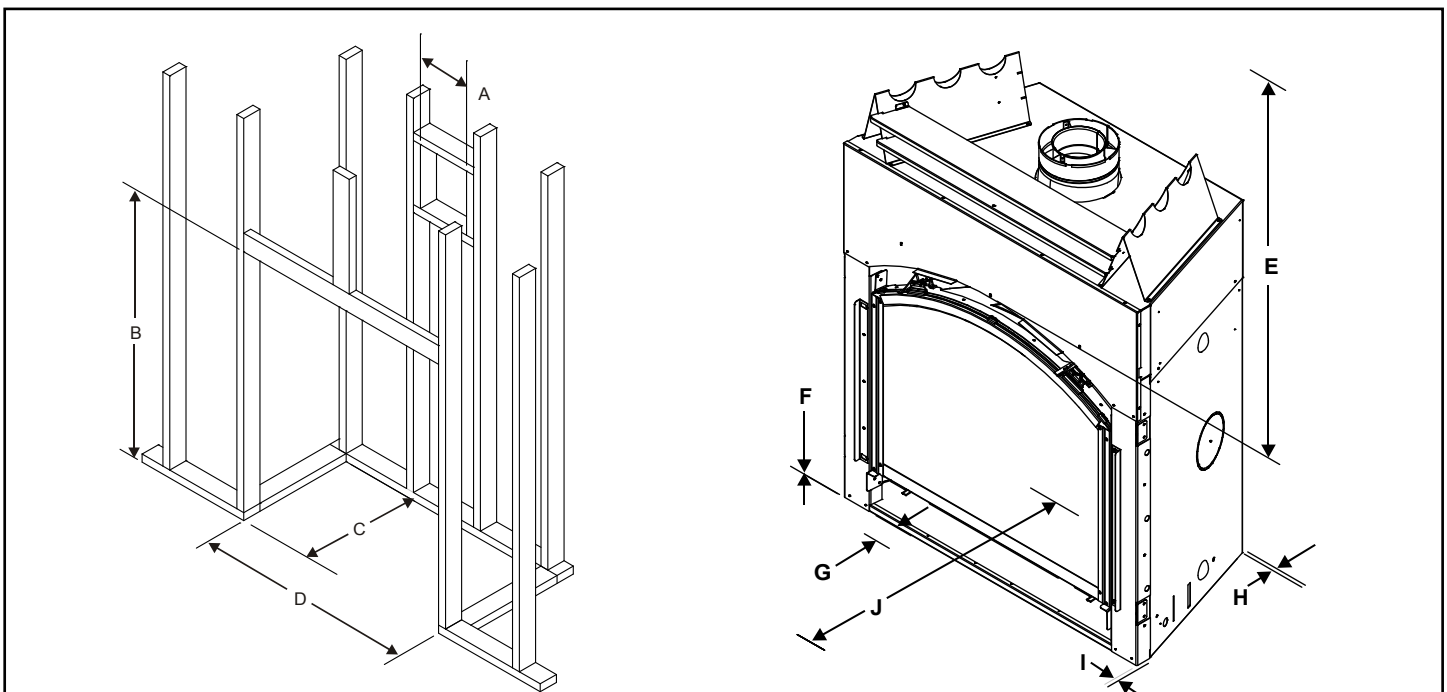

CLEARANCES TO COMBUSTIBLES:

		A	B	C	D	E	F	G	H	I	J
		Rough Opening (Vent Pipe)	Rough Opening (Height)	Rough Opening (Depth)	Rough Opening (Width)	Clearance to Ceiling from Top of Arch Opening	Combustible Floor	Combustible Flooring	Behind Appliance	Sides of Appliance	Front of Appliance
Cerona-36	in	10	50-1/2	22-1/4	42-1/8	49	0	8	1/2	1/2	36
	mm	254	1283	565	1070	1245	0	203	13	13	914
Cerona-42	in	10	54-1/2	22-1/4	49-1/8	45-1/4	0	8	1/2	1/2	36
	mm	254	1384	565	1248	1149	0	203	13	13	914

Figure 5.2 Clearances to Combustibles

D. Mantel and Wall Projections

WARNING! Risk of Fire! Comply with all minimum clearances as specified. Framing or finishing material closer than the minimums listed must be constructed entirely of non-combustible materials (i.e., steel studs, concrete board, etc).

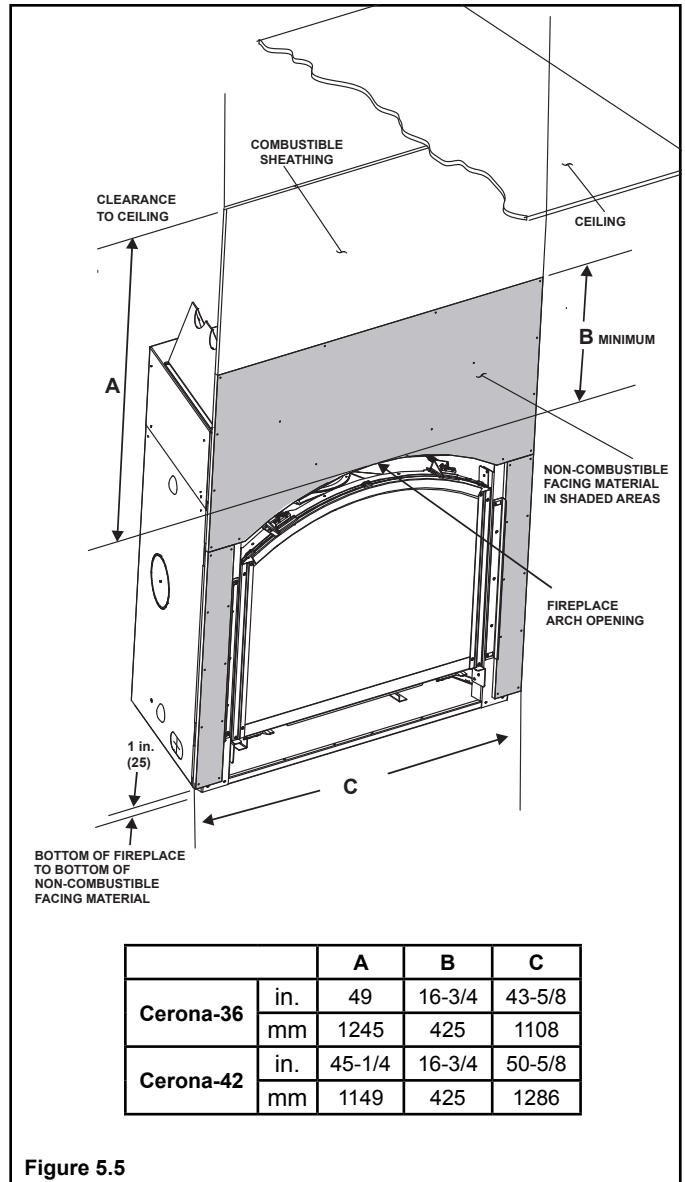
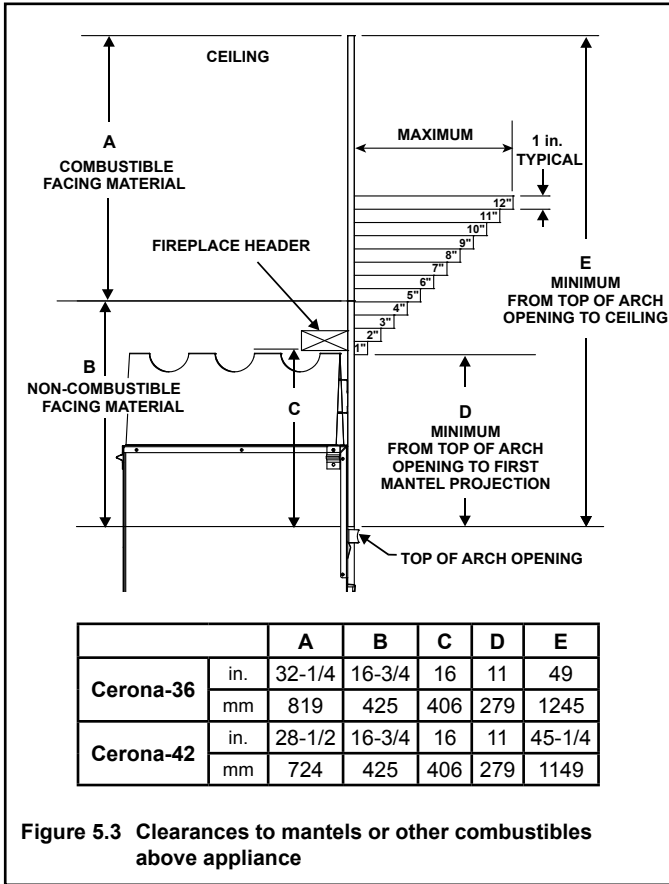

Note: If using the Apollo Mantel System, the appliance must be raised 1-1/4 in. from floor.

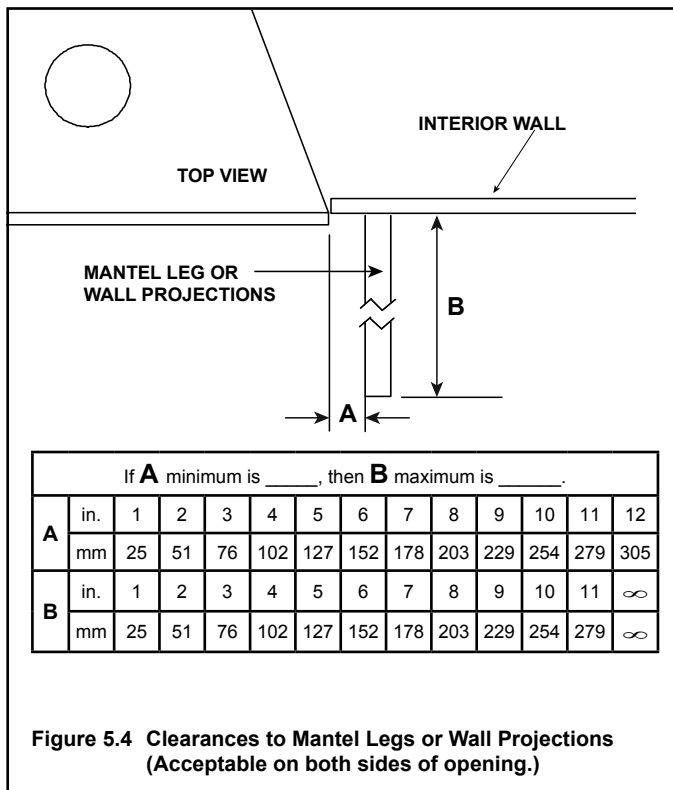

E. Hearth Extension

WARNING! Risk of Fire! Hearth extension required to protect combustible floors in front of appliance.

- An 8 inch minimum hearth extension must be constructed of non-combustible material.

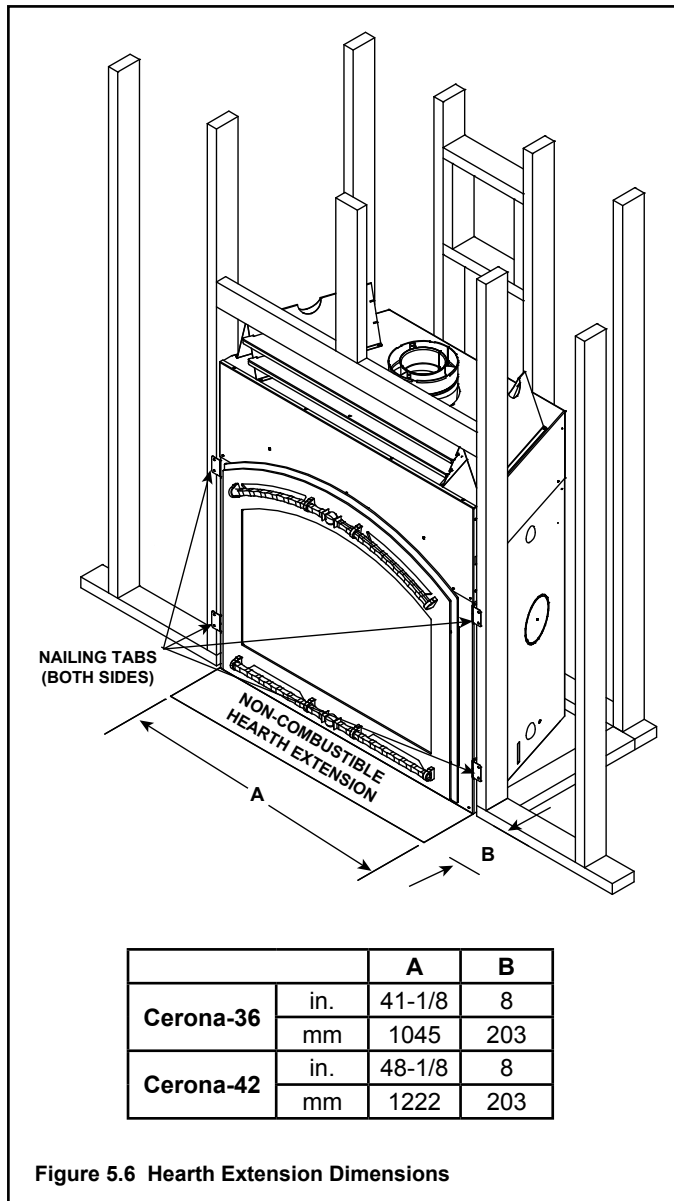

The base of the fireplace may sit on a combustible surface. The area in front of the fireplace must be protected by a noncombustible hearth extension, unless the fireplace is raised a minimum of 6 inches above the combustible floor or hearth. See Figures 5.6, 5.7 and 5.8.

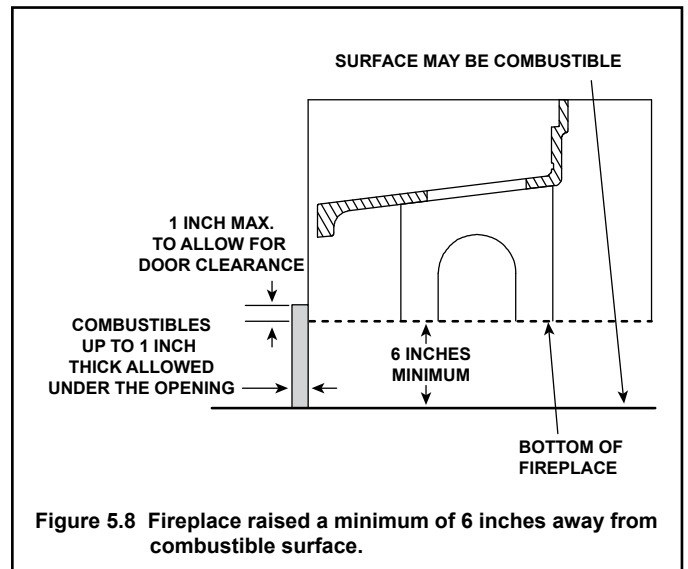
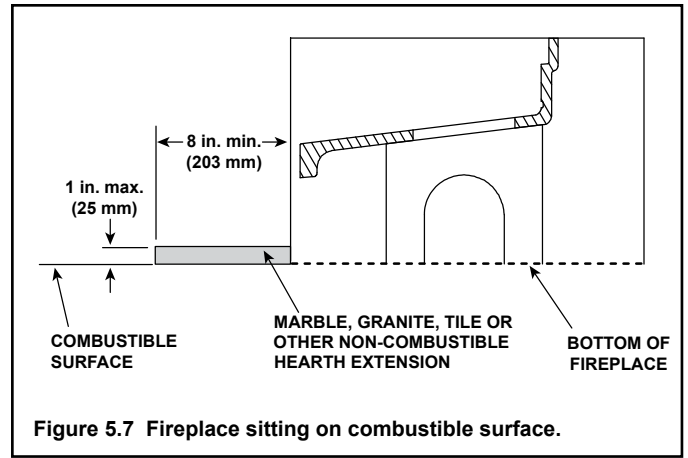

6 Termination Locations

A. Vent Termination Minimum Clearances

WARNING

Fire Risk.
Maintain vent clearance to combustibles as specified.

- **DO NOT** pack air space with insulation or other materials.

Failure to keep insulation or other materials away from vent pipe may cause overheating and fire.

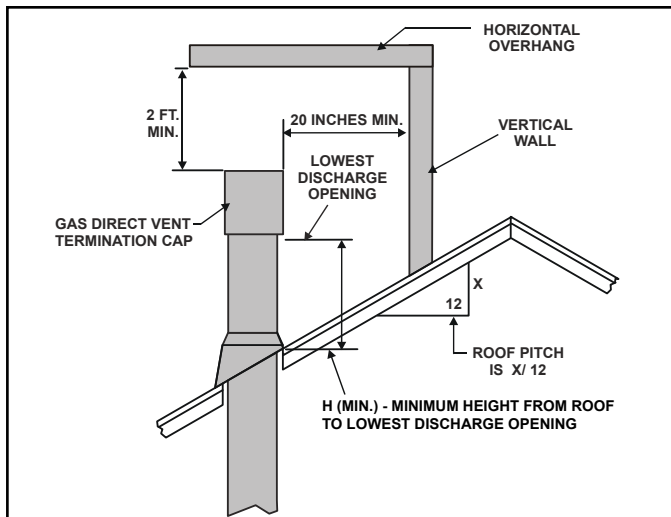

Roof Pitch	H (Min.) Ft.
Flat to 6/12.....	1.0*
Over 6/12 to 7/12.....	1.25*
Over 7/12 to 8/12.....	1.5*
Over 8/12 to 9/12.....	2.0*
Over 9/12 to 10/12.....	2.5*
Over 10/12 to 11/12.....	3.25
Over 11/12 to 12/12.....	4.0
Over 12/12 to 14/12.....	5.0
Over 14/12 to 16/12.....	6.0
Over 16/12 to 18/12.....	7.0
Over 18/12 to 20/12.....	7.5
Over 20/12 to 21/12.....	8.0

* 3 foot minimum in snow regions

Figure 6.1 Minimum Height From Roof To Lowest Discharge Opening

A	B
6 in. (minimum) up to 20 in. <i>152 mm/508 mm</i>	18 in. minimum <i>457 mm</i>
20 in. and over	0 in. minimum

Gas, Wood or Fuel Oil Termination Cap

Gas Termination Cap **

* If using decorative cap cover(s), this distance may need to be increased. Refer to the installation instructions supplied with the decorative cap cover.

** In a staggered installation with both gas and wood or fuel oil terminations, the wood or fuel oil termination cap must be higher than the gas termination cap.

Figure 6.2 Staggered Termination Caps

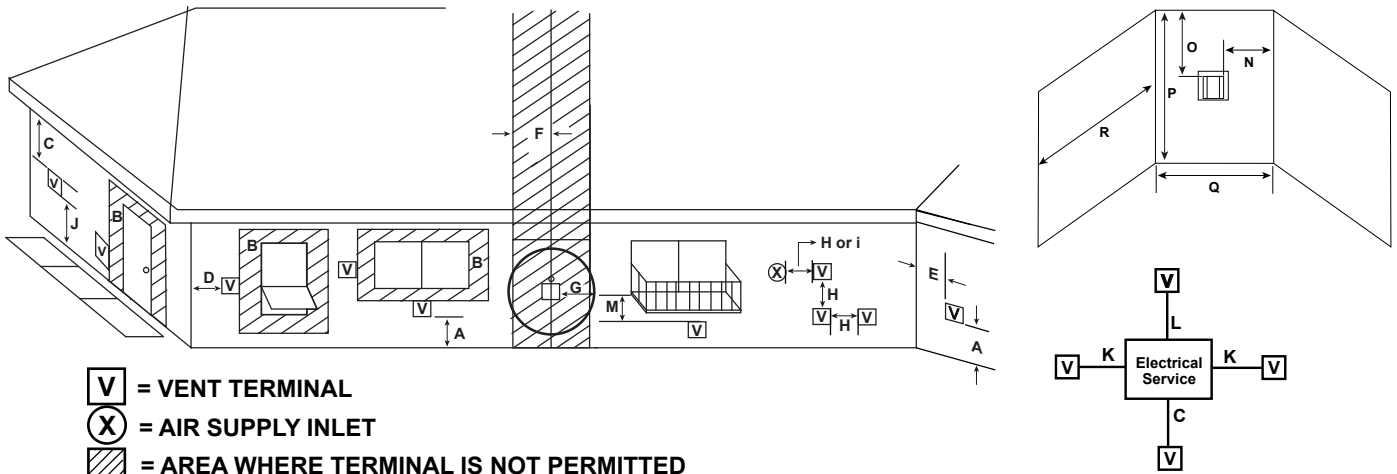

- V** = VENT TERMINAL
- X** = AIR SUPPLY INLET
- ▨** = AREA WHERE TERMINAL IS NOT PERMITTED

- A = 12 inches.....clearances above grade, veranda, porch, deck or balcony
- B = 12 inches.....clearance to window or door that may be opened, or to permanently closed window
- C = 18 inches.....clearance below unventilated soffit
18 inches.....clearance below ventilated soffit
30 inches.....clearance below vinyl soffits and electrical service
- D = 6 inches.....clearance to outside corner
- E = 6 inches.....clearance to inside corner
- F = 3 ft. (Canada).....not to be installed above a gas meter/regulator assembly within 3 feet horizontally from the center-line of the regulator
- G = 3 ft.....clearance to gas service regulator vent outlet
- H = 12 inches.....clearance to non-mechanical (unpowered) air supply inlet, combustion air inlet or direct-vent termination
- i = 3 ft. (U.S.A.)
6 ft. (Canada).....clearance to a mechanical (powered) air supply inlet

All mechanical air intakes within 10 feet of a termination cap must be a minimum of 3 feet below termination.

J = 7 ft. On **public** property: clearance above paved sidewalk or a paved driveway.

A vent shall not terminate directly above a sidewalk or paved driveway which is located between two single family dwellings and serves both dwellings.

- K = 6 inches.....clearance from sides of electrical service
- L = 12 inches.....clearance above electrical service
Location of the vent termination must not interfere with access to the electrical service.

M = 18 inchesclearance under veranda, porch, deck, balcony or overhang
42 inchesvinyl or composite overhang
Permitted when veranda, porch, deck or balcony is fully open on a minimum of 2 sides beneath the floor.

Figure 6.3 Minimum Clearances for Termination

Covered Alcove Applications
(Spaces open only on one side and with an overhang)

- N = 6 inches non-vinyl sidewalls
12 inches vinyl sidewalls
- O = 18 inches non-vinyl soffit and overhang
42 inches vinyl soffit and overhang
- P = 8 ft.

	Q_{MIN}	R_{MAX}
1 cap	3 feet	2 x Q _{ACTUAL}
2 caps	6 feet	1 x Q _{ACTUAL}
3 caps	9 feet	2/3 x Q _{ACTUAL}
4 caps	12 feet	1/2 x Q _{ACTUAL}
Q_{MIN} = # termination caps x 3 R_{MAX} = (2 / # termination caps) x Q_{ACTUAL}		

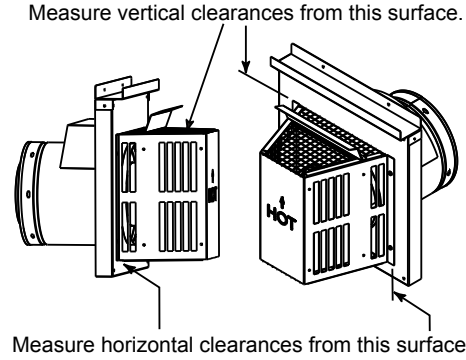

CAUTION! Risk of Burns! Termination caps are **HOT**, consider proximity to doors, traffic areas or where people may pass or gather (sidewalk, deck, patio, etc.). Listed cap shields available. Contact your dealer.

- Local codes or regulations may require different clearances.
- Vent system termination is **NOT** permitted in screened porches.
- Vent system termination is permitted in porch areas with two or more sides open.
- Hearth & Home Technologies assumes no responsibility for the improper performance of the appliance when the venting system does not meet these requirements.
- Vinyl protection kits are suggested for use with vinyl siding.

7 Vent Information and Diagrams

A. Approved Pipe

This appliance is approved for use with Hearth & Home Technologies DVP venting systems. Refer to Section 16.B for vent component information.

DO NOT mix pipe, fittings or joining methods from different manufacturers.

The pipe is tested to be run inside an enclosed wall. There is no requirement for inspection openings at each joint within the wall.

WARNING! Risk of Fire or Asphyxiation. This appliance requires a separate vent. **DO NOT** vent to a pipe serving a separate solid fuel burning appliance.

B. Vent Table Key

The abbreviations listed in this vent table key are used in the vent diagrams.

Symbol	Description
V ₁	First section (closest to appliance) of vertical length
V ₂	Second section of vertical length
H ₁	First section (closest to appliance) of horizontal length
H ₂	Subsequent sections of horizontal length

C. Use of Elbows

Diagonal runs have both vertical and horizontal vent aspects when calculating the effects. Use the rise for the vertical aspect and the run for the horizontal aspect (see Figure 7.1).

Two 45° elbows may be used in place of one 90° elbow. On 45° runs, one foot of diagonal is equal to 8-1/2 in. (216 mm) horizontal run and 8-1/2 in. (216 mm) vertical run. A length of straight pipe is allowed between two 45° elbows (see Figure 7.1).

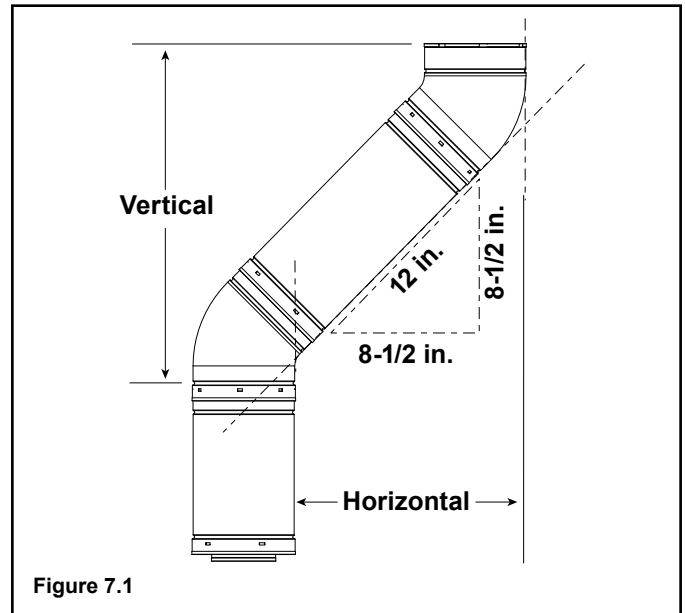

Figure 7.1

D. Measuring Standards

Vertical and horizontal measurements listed in the vent diagrams were made using the following standards.

- Pipe measurements are shown using the effective length of pipe (see Figure 7.2).
- Horizontal terminations are measured to the outside mounting surface (flange of termination cap) (see Figure 6.3).
- Vertical terminations are measured to bottom of termination cap.
- Horizontal pipe installed level with no rise.

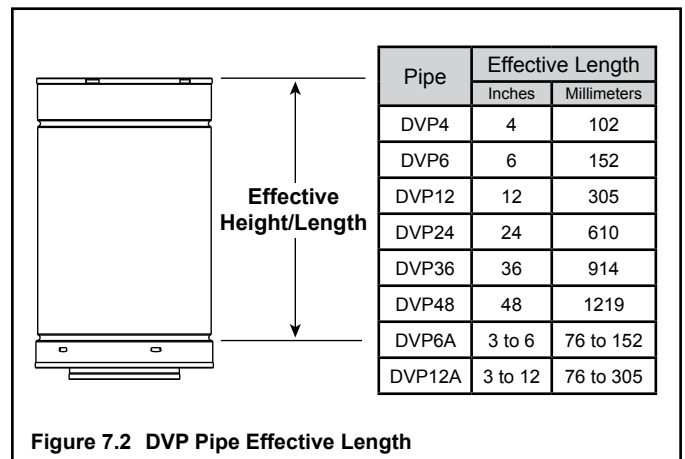

Figure 7.2 DVP Pipe Effective Length

E. Adding Vent Components

Make sure that the fiberglass rope ring supplied in the manual bag seals between the first vent component and the outer appliance wrap. See Figure 7.3.

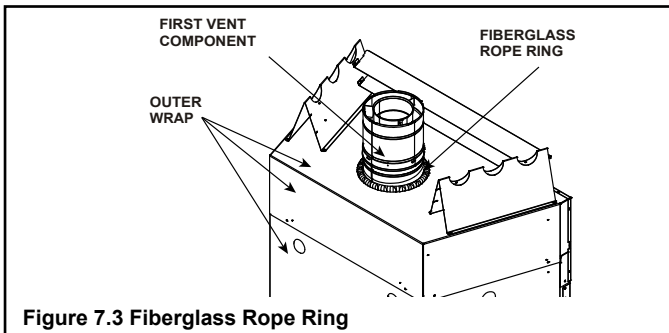

Figure 7.3 Fiberglass Rope Ring

WARNING

Fire Risk.

Installation of this appliance may require the use of heat shield 385-290 above the first 90° elbow in the venting system.

To Install the Heat Shield:

1. Determine if the heat shield is required. Do so by measuring the vertical distance between the top horizontal surface of the elbow to any combustible surface above. If the distance is more than 4 inches, the heat shield is **NOT** required. If it is 4 inches or less, the heat shield **IS REQUIRED**. Install per the following steps. See Figure 7.4.

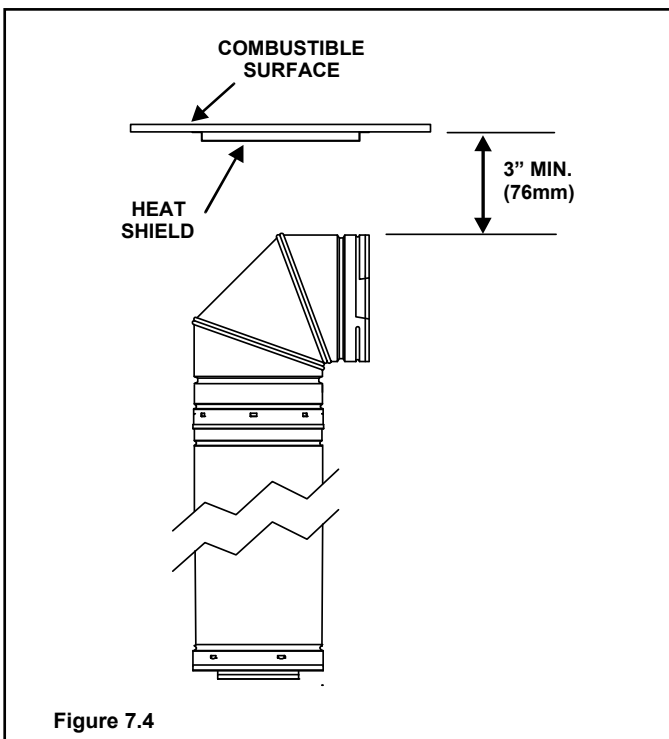

Figure 7.4

2. Fasten the shield in place using the four pilot holes provided in the part. The shield should be oriented such that the 13 1/8 inch dimension (longest dimension) is running in the same direction the elbow is pointing. The shield should be centered directly above the elbow, and positioned so that it creates a 1/2 inch airspace between the shield and the combustible surface. See Figure 7.5.

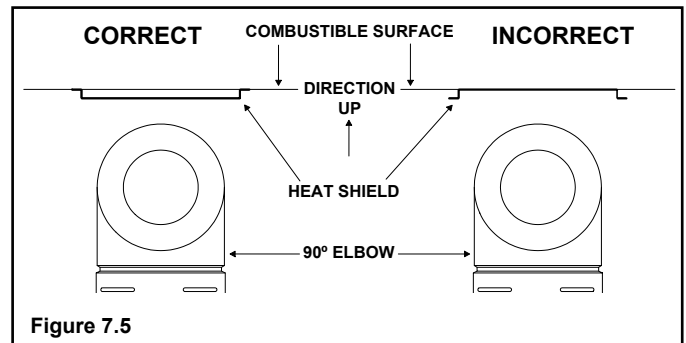

Figure 7.5

- If the combustible materials are not in place at the time of install the elbow heat shield may be screwed to the exhaust pipe (see Figure 7.6). Cut the tabs as shown and bend down. Secure the heat shield to the pipe maintaining 3 inch to 4 inch between the pipe and shield.

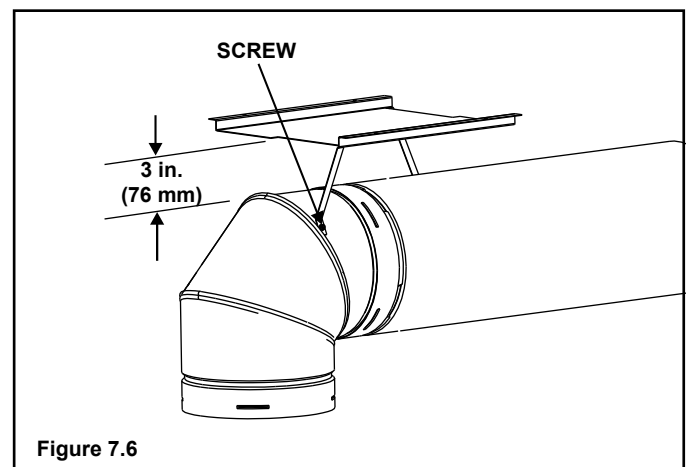

Figure 7.6

Refer to Cinch Pipe and Termination Cap installation instructions.

- Continue adding vent components, locking each succeeding component into place.
- Ensure that each succeeding vent component is securely fitted and locked into the preceding component in the vent system.
- 90° elbows may be installed and rotated to any point around the preceding component's vertical axis. If an elbow does not end up in a locked position with the preceding component, attach with a minimum of two (2) sheet metal screws.

F. Install Support Brackets

Refer to Cinch Pipe and Termination Cap installation instructions.

Top Vent - Horizontal Termination

⚠ WARNING



Fire Risk. Explosion Risk.

Do NOT pack insulation or other combustibles between ceiling firestops.

- ALWAYS maintain specified clearances around venting and firestop systems.
- Install wall shield and ceiling firestops as specified.

Failure to keep insulation or other material away from vent pipe may cause fire.

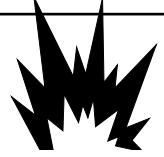

1. Top Vent - Horizontal Termination

One Elbow

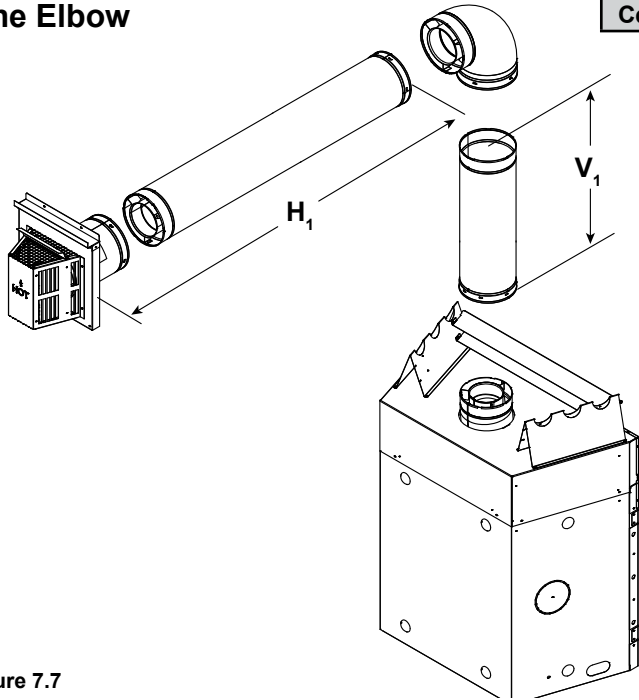

Cerona-36 ONLY

V ₁ Minimum		H ₁ Maximum	
1/2 ft	152 mm	2 ft	610 mm
1 ft	305 mm	2 ft	610 mm
2 ft	610 mm	5 ft	1.5 m
3 ft	914 mm	8 ft	2.4 m
4 ft	1.2 m	11 ft	3.4 m
5 ft	1.5 m	14 ft	4.3 m
6 ft	1.8 m	17 ft	5.2 m
7 ft	2.1 m	20 ft	6.1 m
8 ft	2.4 m	23 ft	7.0 m
V₁ = 40 ft. (12.2 m) Maximum H₁ = 23 ft. (7.0 m) Maximum V₁ + H₁ = 63 ft. (19.2 m) Maximum			

Note: Must have a minimum vertical vent before attaching a 90° elbow to the unit. See chart.	Minimal Vertical Vent		
	Model	ft.	mm
	Cerona-36	1/2	152
	Cerona-42	1	305

Figure 7.7

Two Elbows

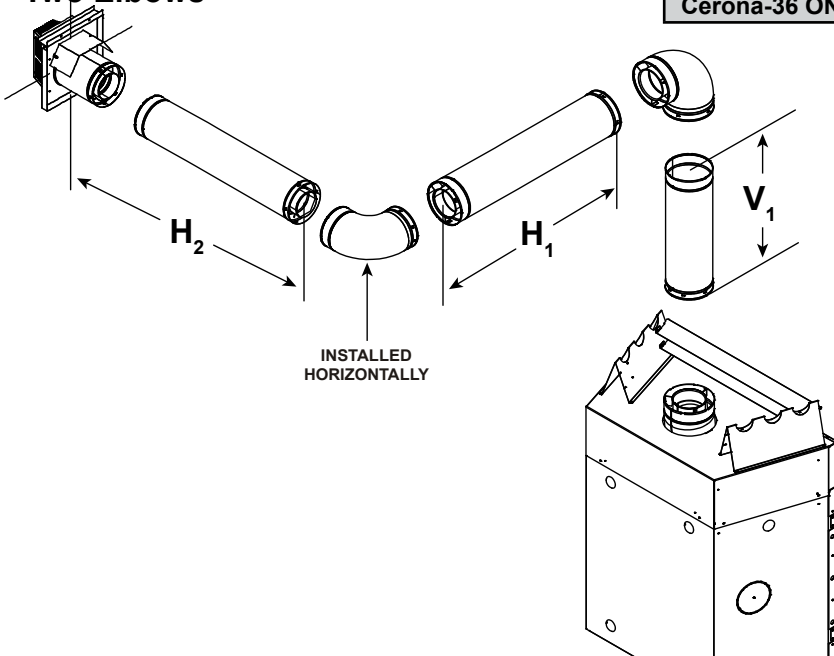

Cerona-36 ONLY

V ₁ Minimum		H ₁ + H ₂ Maximum	
1/2 ft	152 mm	2 ft	610 mm
1 ft	305 mm	2 ft	610 mm
2 ft	610 mm	5 ft	1.5 m
3 ft	914 mm	8 ft	2.4 m
4 ft	1.2 m	11 ft	3.4 m
5 ft	1.5 m	14 ft	4.3 m
6 ft	1.8 m	17 ft	5.2 m
7 ft	2.1 m	20 ft	6.1 m
8 ft	2.4 m	23 ft	7.0 m
V₁ + H₁ + H₂ = 63 ft. (19.2 m) Maximum H₁ + H₂ = 23 ft. (7.0 m) Maximum			

Note: Must have a minimum vertical vent before attaching a 90° elbow to the unit. See chart.	Minimal Vertical Vent		
	Model	ft.	mm
	Cerona-36	1/2	152
	Cerona-42	1	305

Figure 7.8

Top Vent - Horizontal Termination - (continued)

Three Elbows

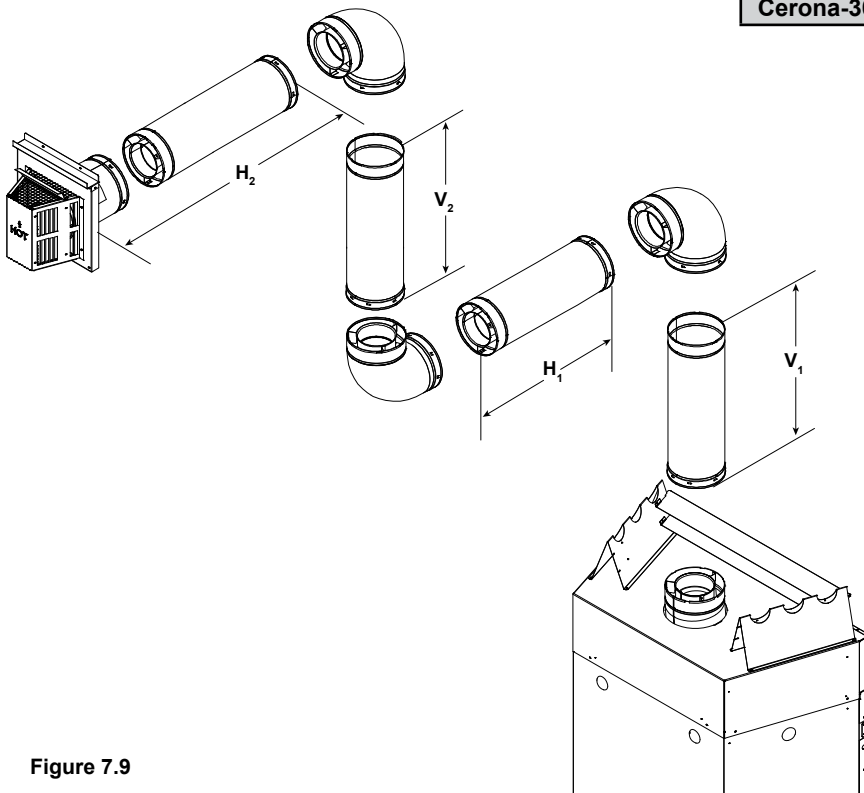

Cerona-36 ONLY	V ₁ Minimum		H ₁ + H ₂ Maximum	
	ft	mm	ft	mm
	1/2	152	3	914
	1	305	4	1.2 m
	2	610	7	2.1 m
	3	914	10	3.0 m
	4	1.2 m	13	4.0 m
	5	1.5 m	16	4.9 m
	6	1.8 m	17	5.2 m
	7	2.1 m	22	6.7 m

H₁ + H₂ = 22 ft. (6.7 m) Max.
V₁ + V₂ + H₁ + H₂ = 62 ft. (18.9 m) Max.

Note: Must have a minimum vertical vent before attaching a 90° elbow to the unit. See chart.	Minimal Vertical Vent		
	Model	ft.	mm
	Cerona-36	1/2	152
	Cerona-42	1	305

Figure 7.9

2. Top Vent - Vertical Termination Straight up Vertical Venting

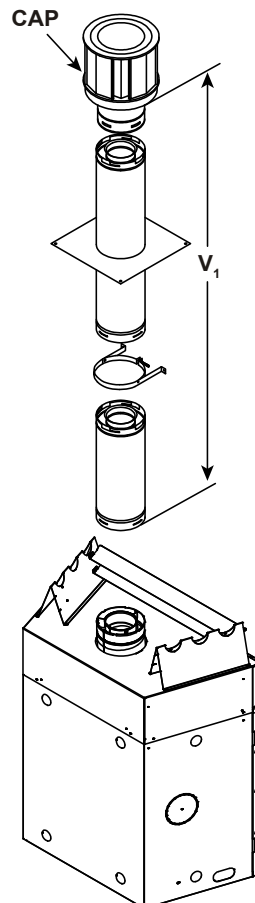

V₁ = 50 ft. Max. (15.2 m)

Note: On vertical venting configurations install the flue restrictor found in the appliance manual bag. Follow flue restrictor instructions in **Section 9.D**.

Figure 7.10

Two Elbows

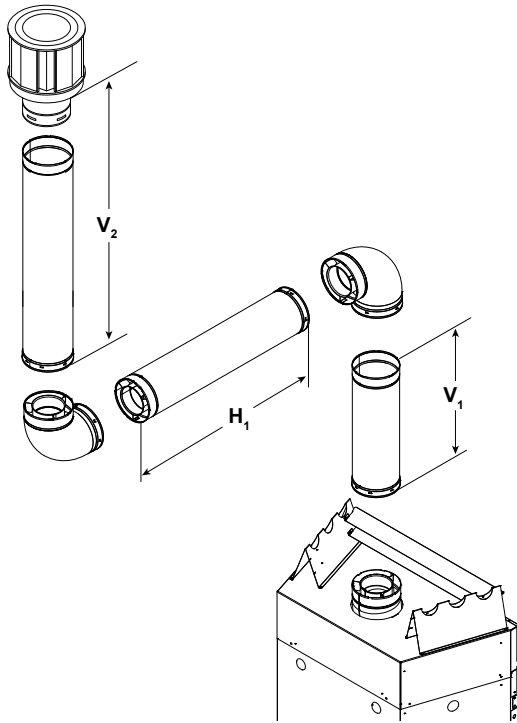

Cerona-36 ONLY	V ₁ Minimum		H ₁ Maximum	
	ft	mm	ft	mm
	1/2	152	2	610
	1	305	2	610
	2	610	5	1.5 m
	3	914	8	2.4 m
	4	1.2 m	11	3.4 m
	5	1.5 m	14	4.3 m
	6	1.8 m	17	5.2 m
	7	2.1 m	20	6.1 m
	8	2.4 m	23	7.0 m
H₁ = 23 ft. (7.0 m) Maximum V₁ + V₂ + H₁ = 63 ft. (19.2 m) Maximum				

Note: Must have a minimum vertical vent before attaching a 90° elbow to the unit. See chart.	Minimal Vertical Vent		
	Model	ft.	mm
	Cerona-36	1/2	152
	Cerona-42	1	305

Figure 7.11

Three Elbows

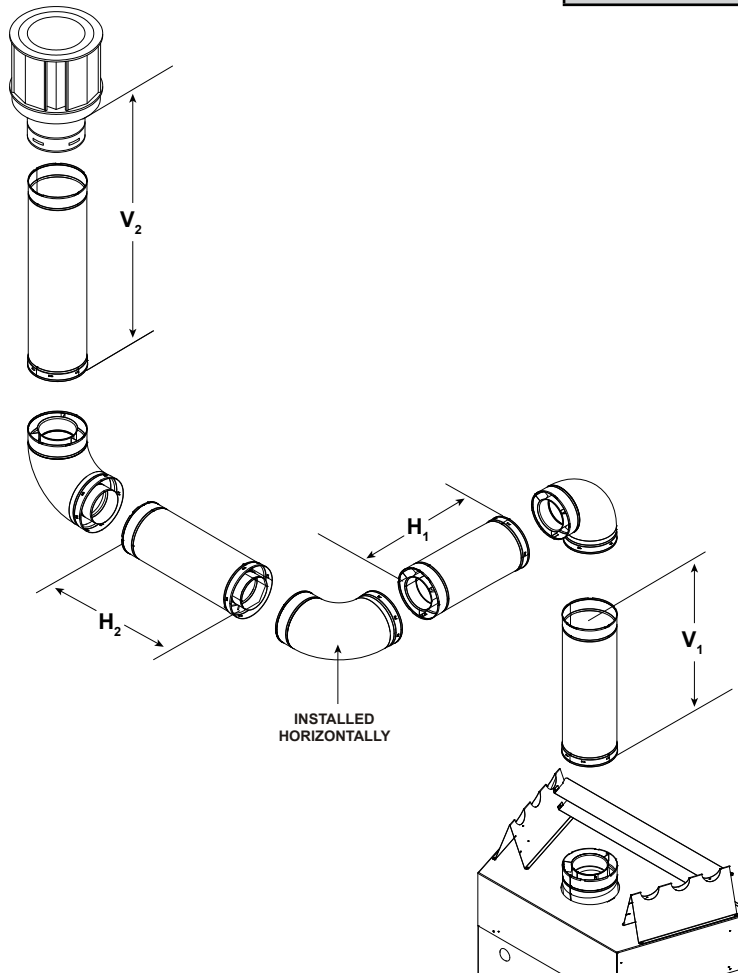

Cerona-36 ONLY	V ₁ Minimum		H ₁ + H ₂ Maximum	
	ft	mm	ft	mm
	1/2	152	3	914
	1	305	4	1.2 m
	2	610	7	2.1 m
	3	914	10	3.0 m
	4	1.2 m	13	4.0 m
	5	1.5 m	16	4.9 m
	6	1.8 m	17	5.2 m
	7	2.1 m	22	6.7 m
H₁ + H₂ = 22 ft. (6.7 m) Max. V₁ + V₂ + H₁ + H₂ = 62 ft. (18.9 m) Max.				

Note: Must have a minimum vertical vent before attaching a 90° elbow to the unit. See chart.	Minimal Vertical Vent		
	Model	ft.	mm
	Cerona-36	1/2	152
	Cerona-42	1	305

Figure 7.12

8 Vent Clearances and Framing

A. Pipe Clearances to Combustibles

WARNING! Risk of Fire! Maintain air space clearance to vent. DO NOT pack insulation or other combustibles:

- Between ceiling firestops
- Between wall shield firestops
- Around vent system

Failure to keep insulation or other material away from vent pipe may cause over heating and fire.

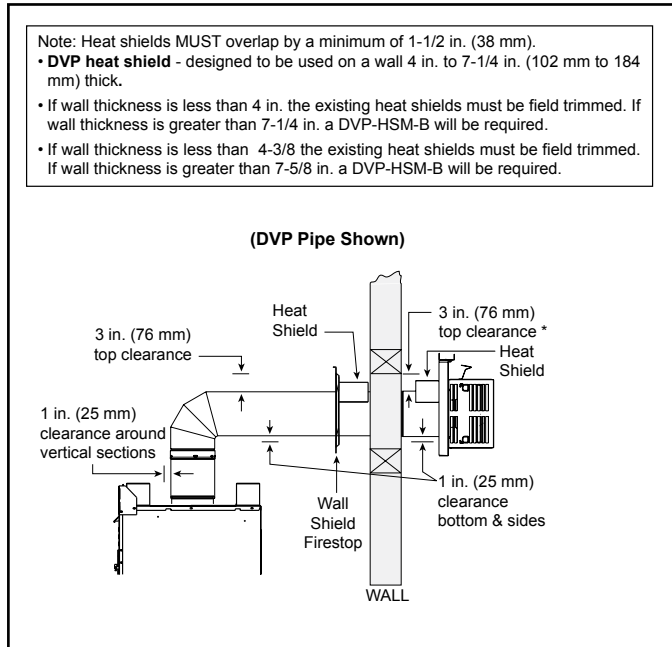

Figure 8.1 Horizontal Venting Clearances To Combustible Materials

B. Wall Penetration Framing

Combustible Wall Penetration

Whenever a combustible wall is penetrated, you must frame a hole for the wall shield firestop(s). The wall shield firestop maintains minimum clearances and prevents cold air infiltration.

- The opening must be framed on all four sides using the same size framing materials as those used in the wall construction.
- DVP pipe - A wall shield firestop is required on one side only on interior walls. If your local inspector requires a wall shield firestop on both sides, then both wall shield firestops must have a heat shield (refer to Section 16.B.) attached to them.
- See Section 10.J for information for regarding the installation of a horizontal termination cap.

Non-Combustible Wall Penetration

If the hole being penetrated is surrounded by non-combustible materials such as concrete, a hole with diameter one inch greater than the pipe is acceptable.

Whenever a non-combustible wall is penetrated, the wall shield firestop is only required on one side and no heat shield is necessary.

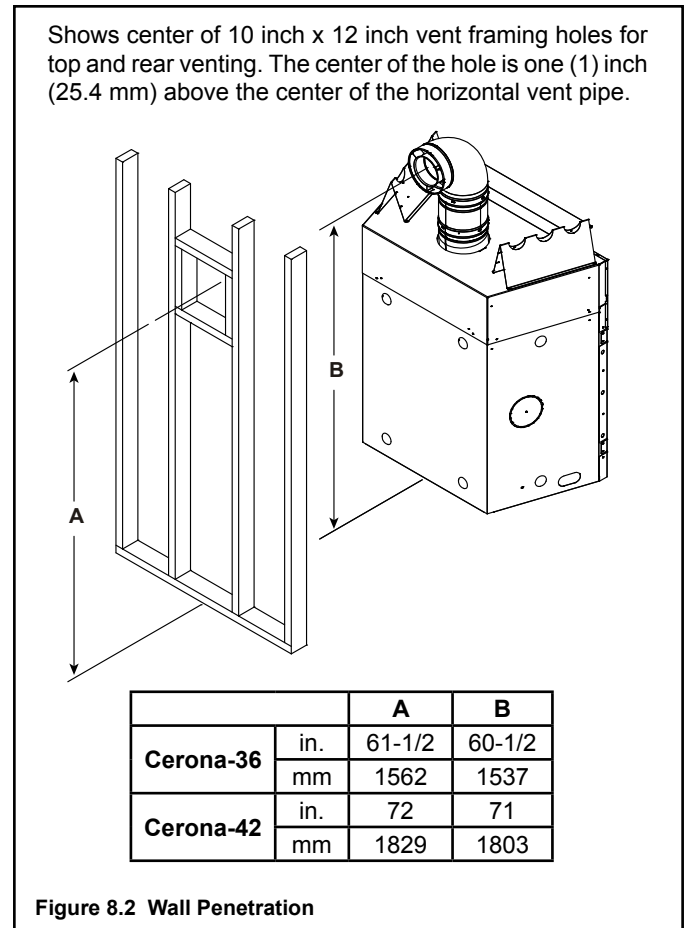

Figure 8.2 Wall Penetration

C. Install the Ceiling Firestop

A ceiling firestop **MUST** be used between floors and attics.

- **DVP pipe only** - Frame an opening 10 in. by 10 in. (254 mm by 254 mm) whenever the vent penetrates a ceiling/floor (see Figure 8.3).
- Frame the area with the same sized lumber as used in ceiling/floor joist.
- The ceiling firestop may be installed above or below the ceiling joists when installed with an attic insulation shield. It must be under joists between floors that are not insulated. Refer to Figure 8.4.
- Secure with three fasteners on each side.

WARNING! Risk of Fire! DO NOT pack insulation around the vent. Insulation must be kept back from the pipe to prevent overheating.

D. Install Attic Insulation Shield

WARNING! Fire Risk. DO NOT allow loose materials or insulation to touch vent. Hearth & Home Technologies requires the use of an attic shield.

The International Fuel Gas Code requires an attic shield constructed of 26 gauge minimum steel that extends at least 2 in. (51 mm) above insulation.

- Attic insulation shields must meet specified clearances to combustible materials and be secured in place.
- An attic insulation shield kit is available from Hearth & Home Technologies. Contact your dealer to order. Install attic insulation shield according to instructions included with kit.

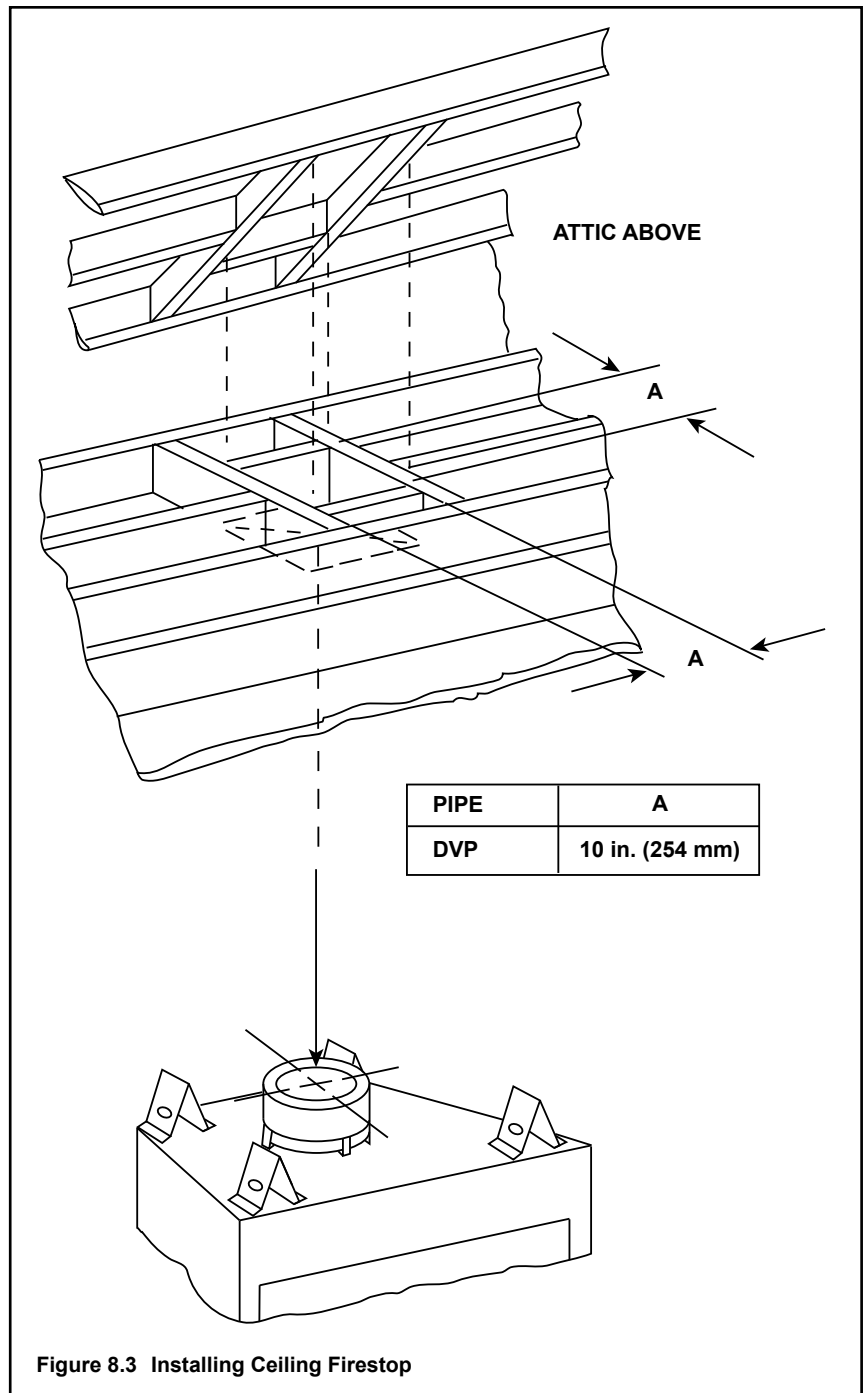

Figure 8.3 Installing Ceiling Firestop

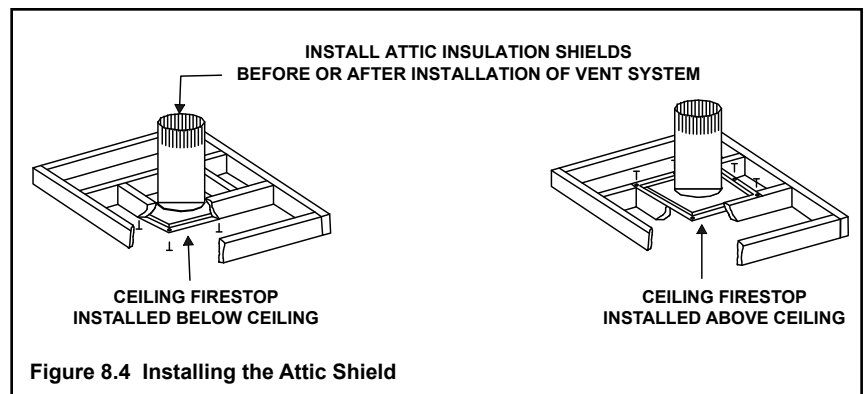

Figure 8.4 Installing the Attic Shield

E. Installing the Optional Heat-Zone® Gas Kit

- Remove the knockout from the sides of the appliance and discard it (see Figure 8.6).

Note: Center the duct collar around the exposed hole and attach it to the appliance with 3 screws **BEFORE** final positioning of the appliance.

- **Heat-Zone:** Determine the location for the air register/fan housing assembly.
- **Heat-Duct:** Determine the location of the entry in the air duct system.
- Reference the Heat-Zone/Heat-Duct Kit instructions for the remaining installation steps.

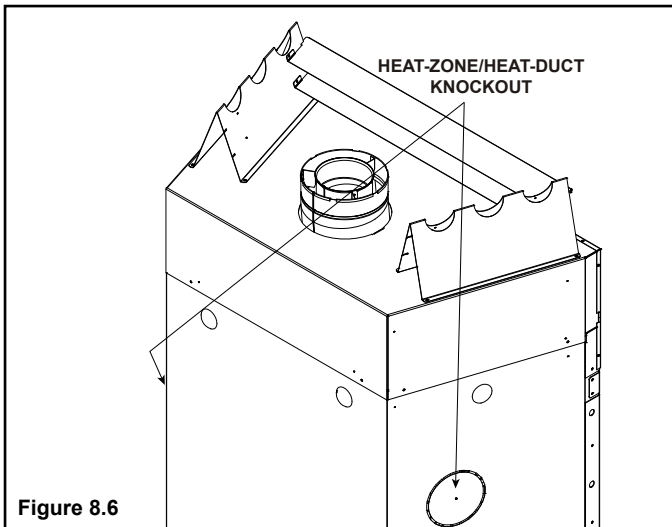

9 Appliance Preparation

A. Removing Non-combustible Facing Material Assembly

CAUTION! Risk of Cuts, Abrasions or Flying Debris. Wear protective gloves and safety glasses during installation. Sheet metal edges are sharp.

The non-combustible assembly is located on the back of appliance (see Figure 9.1).

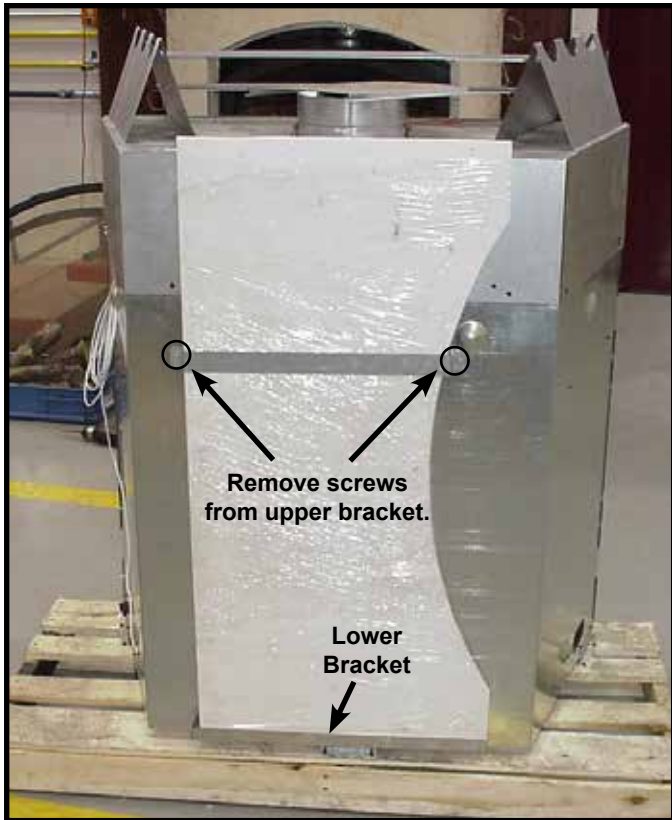

Figure 9.1 Non-Combustible Facing Material Assembly

CAUTION! Handle with care. Non-combustible material may be damaged if dropped.

- Hold non-combustible pieces in place.
- Remove and save two screws from upper brackets (see Figure 9.1).
- Remove non-combustible pieces.
- Remove and save three screws from lower bracket (see Figure 9.1).
- Discard brackets.
- Replace screws in holes where these pieces were attached to appliance.

B. Securing and Leveling the Appliance

WARNING! Risk of Fire! Prevent contact with:

- Sagging or loose insulation
- Insulation backing or plastic
- Framing and other combustible materials

Block openings into the chase to prevent entry of blown-in insulation. Make sure insulation and other materials are secured.

DO NOT notch the framing around the appliance standoffs.

Failure to maintain air space clearance may cause overheating and fire.

The diagram shows how to properly position and secure the appliance (see Figure 9.2). Nailing tabs are provided to secure the appliance to the framing members.

- Bend out nailing tabs on each side.
- Place the appliance into position.
- Keep nailing tabs flush with the framing.
- Level the appliance from side to side and front to back.
- Shim the appliance as necessary. It is acceptable to use wood shims underneath the appliance.
- Secure the appliance to the framing by using nails or screws through the nailing tabs.
- Secure the appliance to the floor by inserting two screws through the pilot holes at the bottom of the appliance.

The diagram shows (Figure 9.2) the location of the nailing tabs provided to secure the appliance to the framing members.

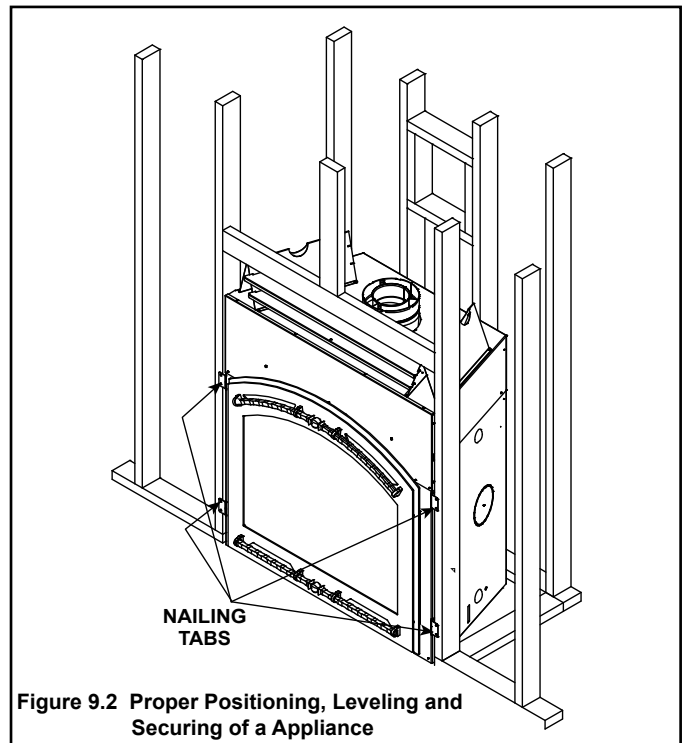

Figure 9.2 Proper Positioning, Leveling and Securing of an Appliance

- Place the appliance into position.
- Level the appliance from side to side and front to back.
- Shim the appliance, as necessary. It is acceptable to use wood shims.
- Bend out nailing tabs on each side.
- Keep nailing tabs flush with the framing.
- Secure the appliance to the framing by using nails or screws through the nailing tabs.

WARNING! Fire Risk. Maintain specified clearances around the appliance. **DO NOT** notch into the framing around the appliance spacers.

C. Installing Non-combustible Facing Material

⚠ WARNING

Fire Risk.

- Follow these instructions exactly.
- Facing materials must be installed properly to prevent fire.
- No materials may be substituted without authorization by Hearth & Home Technologies.

- Center and attach top board to the framing members (see Figure 9.3).
- Use fasteners from fastener packet (in manual bag) in shaded areas (Figure 9.3).
- Use regular sheetrock screws in non-shaded areas (see Figure 9.3).

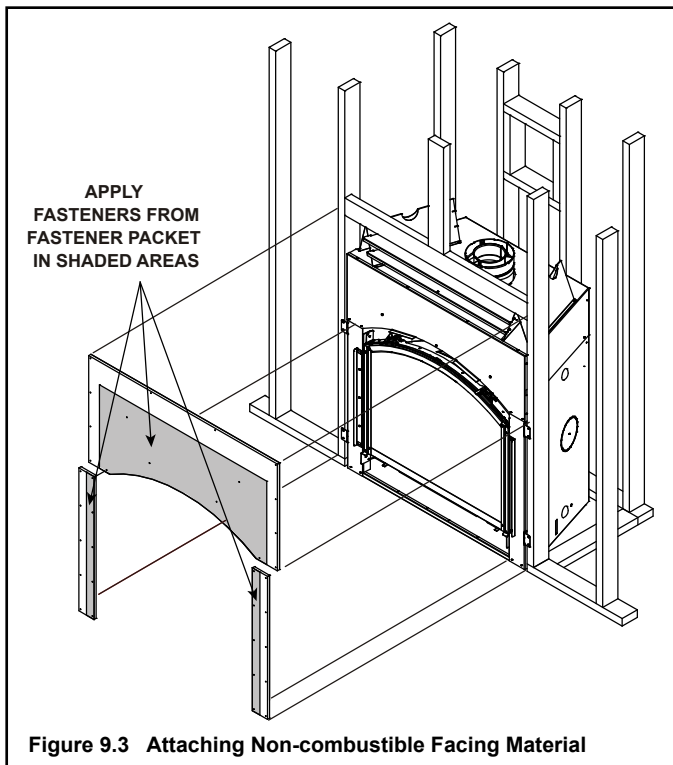

Figure 9.3 Attaching Non-combustible Facing Material

- Attach the left and right side pieces to the framing members. (See Figure 9.3).

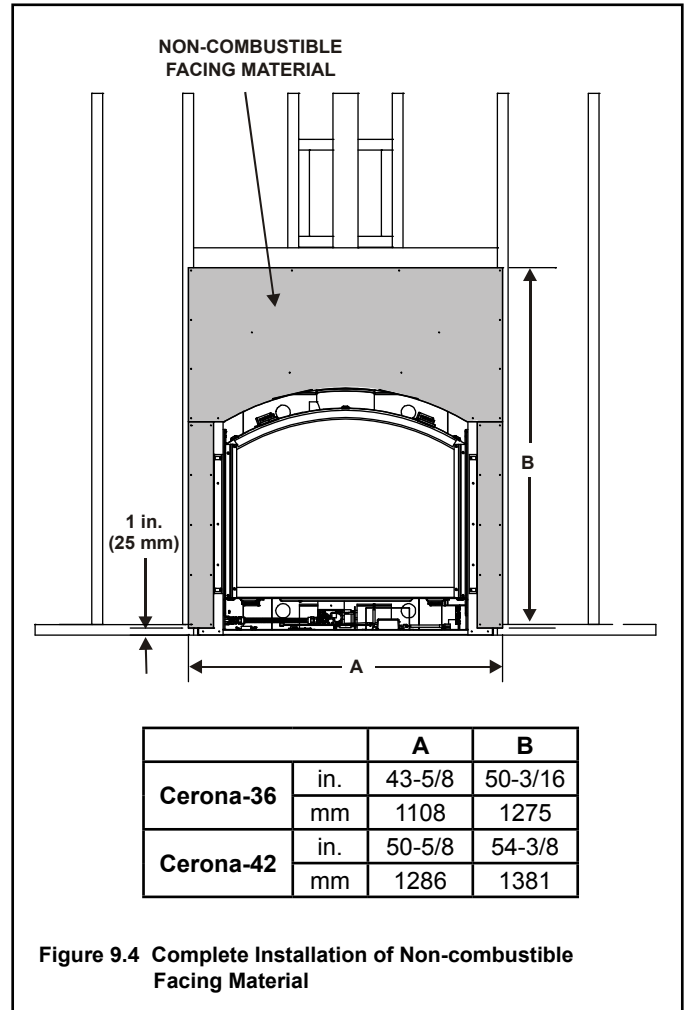

Figure 9.4 Complete Installation of Non-combustible Facing Material

- Use a wet or dry towel or soft brush to remove dust or dirt from facing material.
- Apply a non-combustible adhesive to attach tile, stone or other non-combustible finishing materials per manufacturer's instructions.

D. Installing Flue Restrictors

Locate the flue restrictor and two screws inside the manual bag. Use the following table to determine which restrictors to use for the vent run.

Vent Run Vertical	15 ft. - 50 ft.
Cerona-36	1-1/4
Cerona-42	1-1/4

Mount the flue restrictor to the flapper door using two screws (see Figure 9.5).

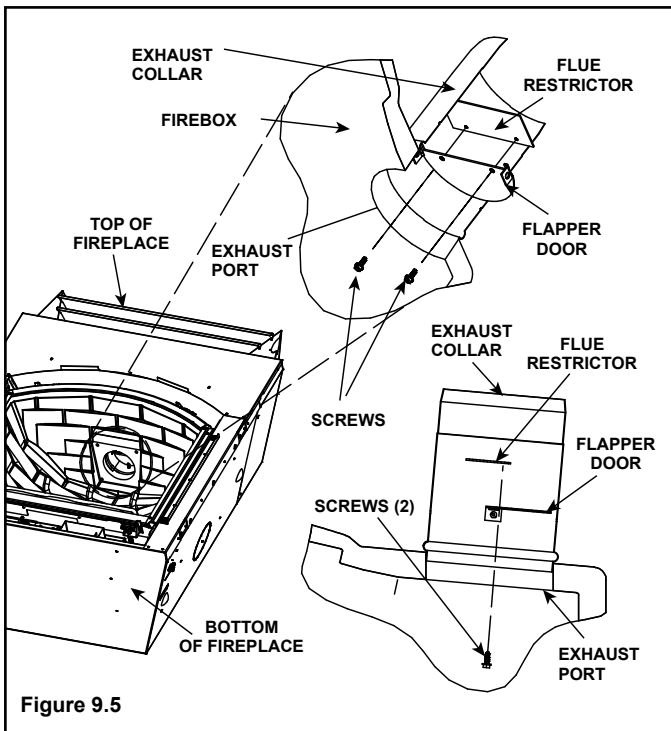

10 Installing Vent Pipe (DVP Pipe)

A. Assemble Vent Sections (DVP Pipe Only)

Attach Vent to the Firebox Assembly

Note: The end of the pipe sections with the lanced tabs will face toward the appliance.

Attach the first pipe section to the starting collar:

- Lanced pipe end of the starting collar.
- Inner pipe over inner collar.
- Push the pipe section until all lanced tabs snap in place.
- Lightly tug on pipe to confirm it has locked.

Commercial, Multi-family (Multi-level exceeding two stories), or High-Rise Applications

All outer pipe joints must be sealed with high temperature silicone (300°F minimum continuous exposure rating), including the slip section that connects directly to the horizontal termination cap.

- Apply a bead of silicone sealant (300°F minimum continuous exposure rating) inside the female outer pipe joint prior to joining sections. See Figure 10.1.
- Only outer pipes need to be sealed. All unit collar, pipe, slip section, elbow and cap outer flues shall be sealed in this manner, unless otherwise stated.

WARNING! Risk of Fire or Explosion! DO NOT break silicone seals on slip sections. Use care when removing termination cap from slip pipe. If slip section seals are broken during removal of the termination cap, vent may leak.

Assemble Pipe Sections

Per Figure 10.2:

- Start the inner pipe on the lanced end of section A into the flared end of section B.
- Start the outer pipe of section A over the outer pipe of section B.
- Once both vents sections are started, push firmly until all lanced tabs lock into place.
- Lightly tug on the pipe to confirm the tabs have locked.

It is acceptable to use screws no longer than 1/2 in. (13 mm) to hold outer pipe sections together. If predrilling holes, **DO NOT** penetrate inner pipe.

For 90° and 45° elbows that are changing the vent direction from horizontal to vertical, one screw minimum should be put in the outer flue at the horizontal elbow joint to prevent the elbow from rotating. Use screws no longer than 1/2 in. (13 mm). If predrilling screw holes, **DO NOT** penetrate inner pipe.



Figure 10.1 High Temperature Silicone Sealant

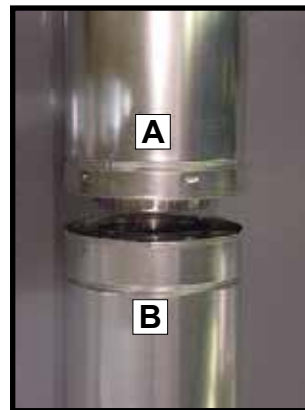

Figure 10.2



Figure 10.3

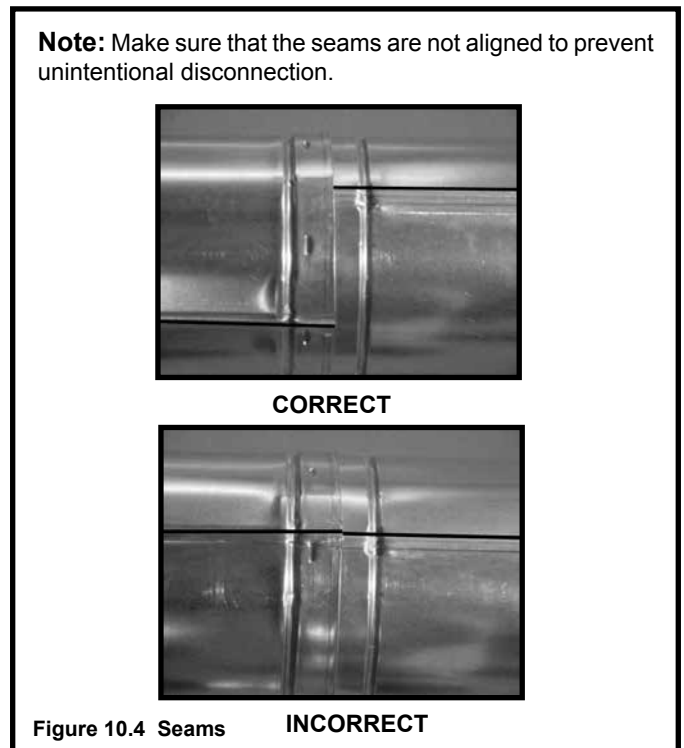

Figure 10.4 Seams

INCORRECT

B. Assemble Slip Sections

- Slide the inner flue of the slip section into the inner flue of the pipe section and the outer flue of the slip section over the outer flue of the pipe section. See Figure 10.5.
- Slide together to the desired length.

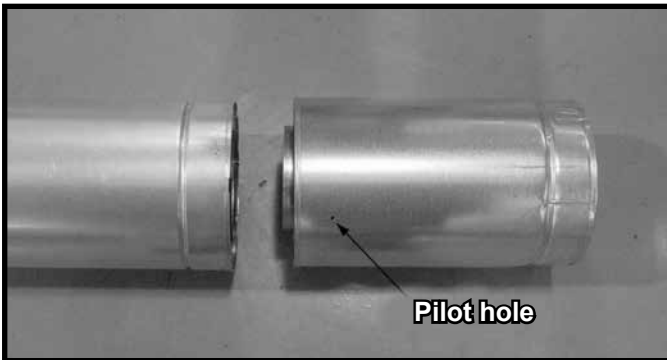

Figure 10.5 Slip Section Pilot Holes

- Maintain a 1-1/2 in. (38 mm) overlap between the slip section and the pipe section.
- Secure the pipe and slip section with two screws no longer than 1/2 in. (13 mm), using the pilot holes in the slip section. See Figure 10.6.

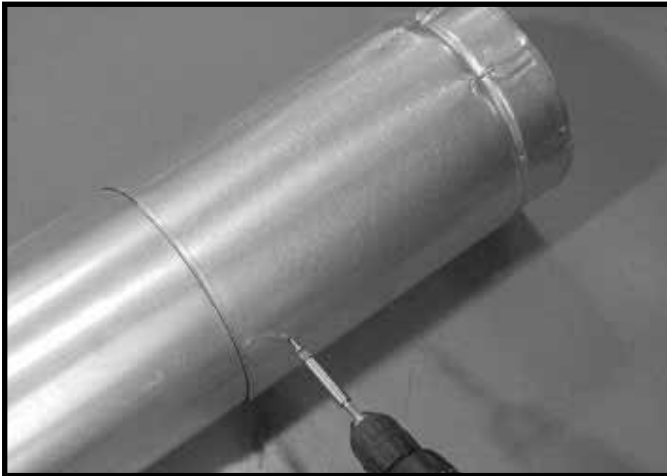

Figure 10.6 Screws into Slip Section

- Continue adding pipe as necessary following instructions in “Assembling Pipe Sections.”

NOTICE: If slip section is too long, the inner and outer flues of the slip section can be cut to the desired length.

C. Secure the Vent Sections

- Vertical runs originating off the top of the appliance, with no offsets, must be supported every 8 ft. (2.44 m) after the maximum allowed 25 ft. (7.62 m) of unsupported rise.
- Vertical runs originating off the rear of the appliance, or after any elbow, must be supported every 8 ft. (2.44 m).
- Horizontal runs must be supported every 5 feet (1.52 m).
- Vent supports or plumbers strap (spaced 120° apart) may be used to support vent sections. See Figures 10.7 and 10.8
- Wall shield firestops may be used to provide horizontal support to vent sections.

WARNING! Risk of Fire, Explosion or Asphyxiation! Improper support may allow vent to sag and separate. Use vent run supports and connect vent sections per installation instructions. **DO NOT** allow vent to sag below connection point to appliance.

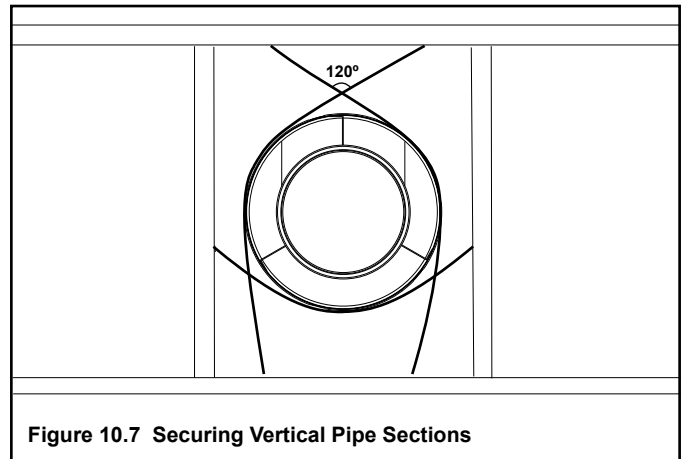

Figure 10.7 Securing Vertical Pipe Sections

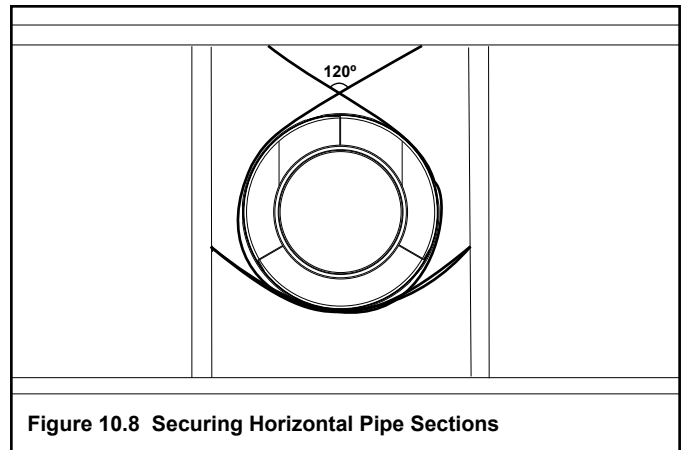

Figure 10.8 Securing Horizontal Pipe Sections

D. Disassemble Vent Sections

- Rotate either section (see Figure 10.9) so the seams on both pipe sections are aligned as shown in Figure 10.10.
- Pull carefully to separate the pieces of pipe.

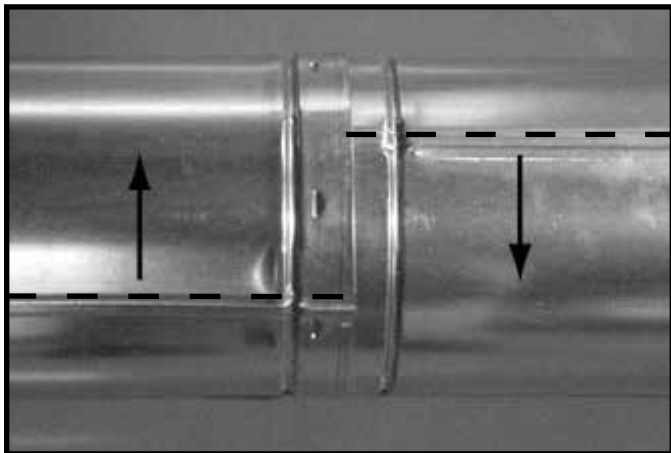

Figure 10.9 Rotate Seams for Disassembly

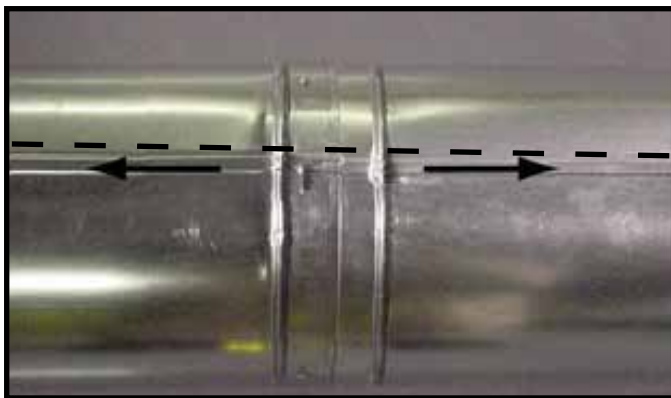

Figure 10.10 Align and Disassemble Vent Sections

E. Install Decorative Ceiling Components

A decorative ceiling thimble can be installed on a flat ceiling through which the vent passes. The decorative ceiling thimble is used to cover the firestop.

- Seal the gap between the vent pipe and firestop using high temperature silicone (300°F minimum continuous exposure rating) to prevent cold air infiltration.
- Install the decorative ceiling thimble by sliding it up to the ceiling and attaching it using the provided screws.

A decorative cathedral ceiling support box can be installed on a cathedral ceiling through which the vent passes.

- Use a plumb-bob to mark the center line of the venting system on the ceiling and drill a small hole through the ceiling and roof at this point. Locate the hole and mark the outline of the cathedral ceiling support box on the outside roof.
- Remove shingles or other roof covering as necessary to cut the rectangular hole for the support box. Cut the hole 1/8 in. (3 mm) larger than the support box outline.

- Lower the support box through the hole in the roof until its bottom is at least 2 in. (51 mm) below the ceiling (Figure 10.11).
- Level the support box both vertically and horizontally and temporarily tack it in place through the inside walls into the roof sheathing.
- Use tin snips to cut the support box from the top corners down to the roof line and fold the resulting flaps to the roof. See Figure 10.12.
- Nail the flaps to the roof AFTER running a bead of non hardening sealant between the flaps and the roof.

WARNING! Risk of Fire! Clean out ALL materials from inside the support box and complete the vertical vent run and termination.

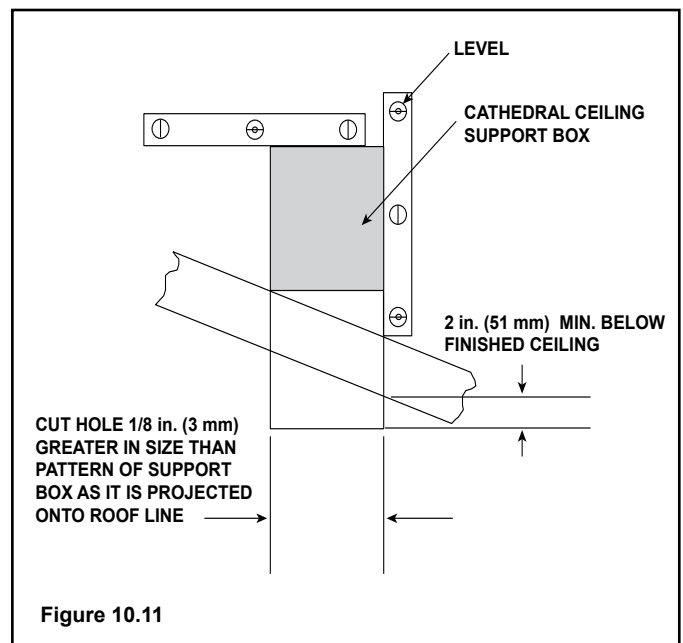

Figure 10.11

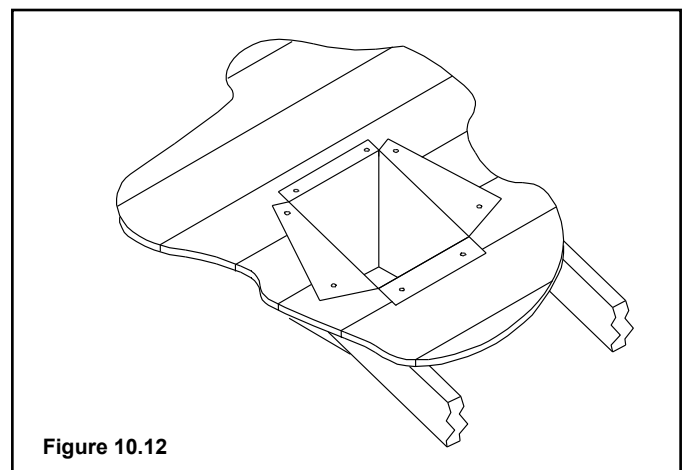
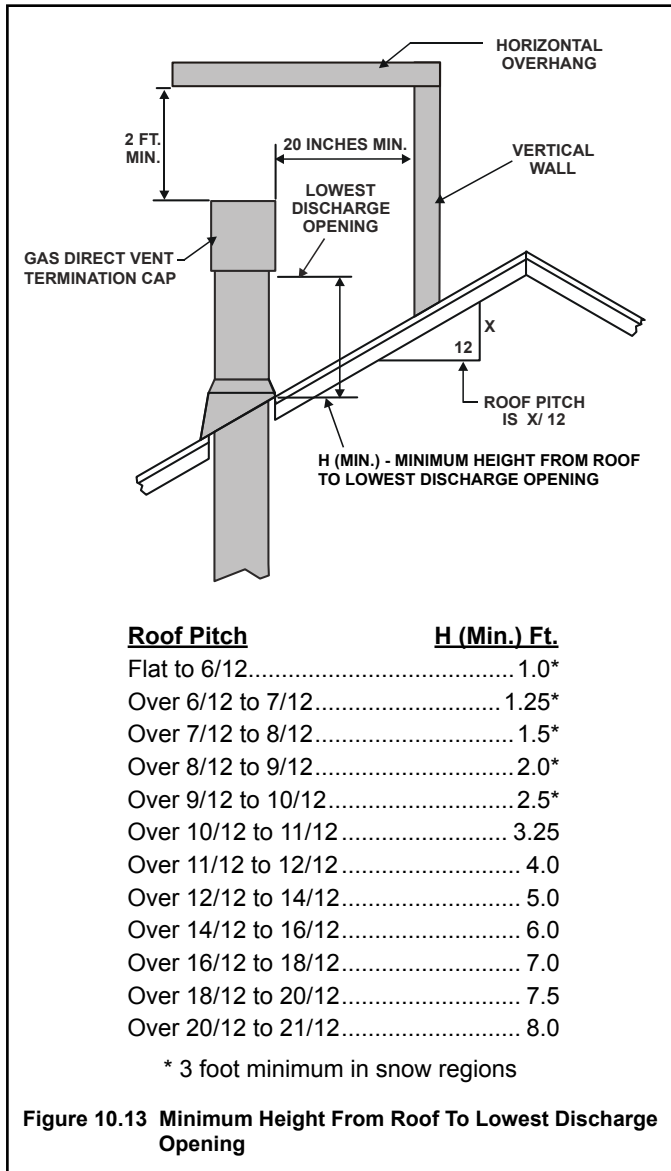

Figure 10.12

F. Install Metal Roof Flashing

- See minimum vent heights for various pitched roofs (Figure 10.13) to determine the length of pipe to extend through the roof.
- Slide the roof flashing over the pipe sections extending through the roof as shown in Figure 10.14.



NOTICE: Failure to properly caulk the roof flashing and pipe seams may permit entry of water.

- Caulk the gap between the roof flashing and the outside diameter of the pipe.
- Caulk the perimeter of the flashing where it contacts the roof surface. See Figure 10.14.
- Caulk the overlap seam of any exposed pipe sections that are located above the roof line.

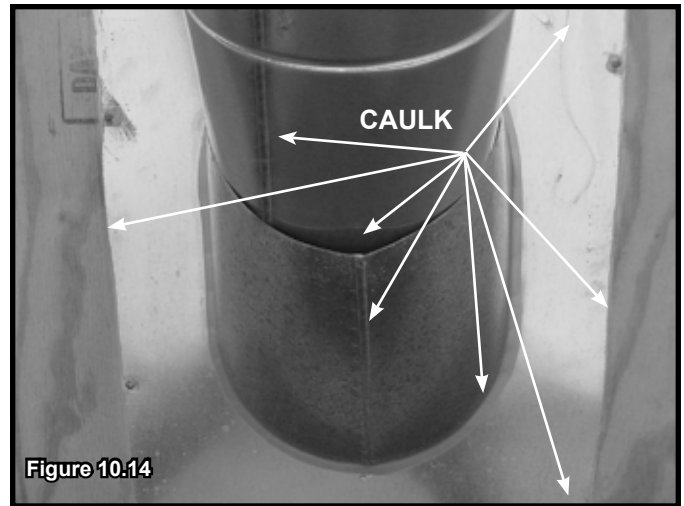

G. Assemble and Install Storm Collar

CAUTION! Risk of Cuts, Abrasions or Flying Debris. Wear protective gloves and safety glasses during installation. Sheet metal edges are sharp.

- Slide the storm collar onto the exposed pipe section and align brackets.
- Insert a bolt (provided) through the brackets and install nut. Do not completely tighten.



- Slide the assembled storm collar down the pipe section until it rests on the roof flashing (see Figure 10.15).
- Tighten nut and make sure the collar is tight against the pipe section.
- Caulk around the top of the storm collar. See Figure 10.16.

H. Install Vertical Termination Cap

- Attach the vertical termination cap by sliding the inner collar of the cap into the inner flue of the pipe section while placing the outer collar of the cap over the outer flue of the pipe section.
- Secure the cap by driving three self-tapping screws (supplied) through the pilot holes in the outer collar of the cap into the outer flue of the pipe (see Figure 10.16).

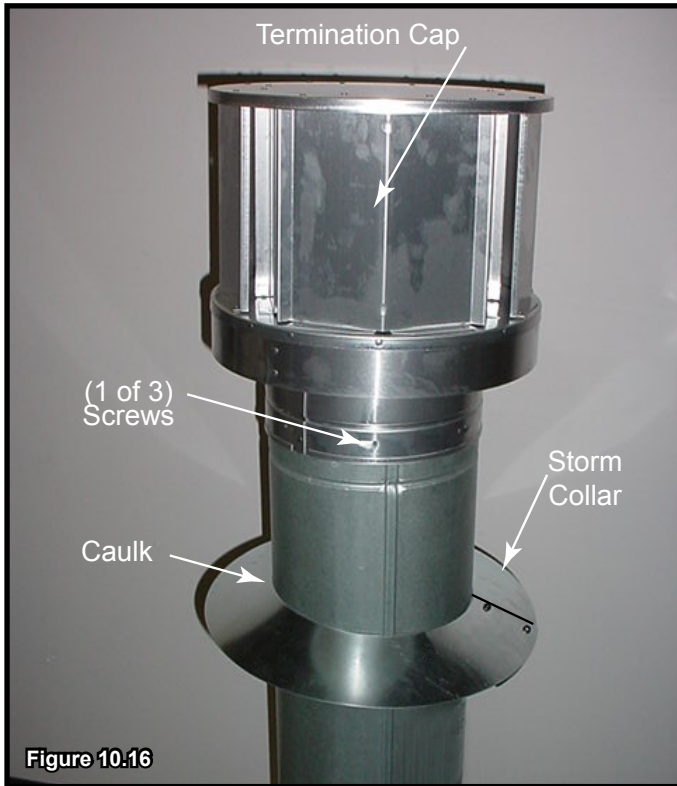

Figure 10.16

I. Heat Shield Requirements for Horizontal Termination

WARNING! Risk of Fire! To prevent overheating and fire, heat shields must extend through the entire wall thickness.

- **DO NOT** remove the heat shields attached to the wall shield firestop and the horizontal termination cap (shown in Figure 10.17).
- Heat shields must overlap 1-1/2 in. (38 mm) minimum.

There are two sections of the heat shield. One section is factory-attached to the wall shield firestop. The other section is factory-attached to the cap. See Figure 10.17.

If the wall thickness does not allow the required 1-1/2 in. (38 mm) heat shield overlap when installed, an extended heat shield must be used.

- If the wall thickness is less than 4 in./102 mm (DVP) or 4-3/8 in./ 111 mm (SLP), the heat shields on the cap and wall shield firestop must be trimmed. A minimum 1-1/2 in. (38 mm) overlap **MUST** be maintained.
- Use an extended heat shield if the finished wall thickness is greater than 7-1/4 in. (184 mm).
- The extended heat shield may need to be cut to length maintaining sufficient length for a 1-1/2 in. (38 mm) overlap between heat shields.
- Attach the extended heat shield to either of the existing heat shields using the screws supplied with the extended heat shield. Refer to vent components diagrams in the back of this manual.
- Rest the small leg on the extended heat shield on top of the pipe section to properly space it from the pipe section.

Important Notice: Heat shields may not be field constructed.

J. Install Horizontal Termination Cap

WARNING! Risk of Fire! The telescoping flue section of the termination cap **MUST** be used when connecting vent.

- 1-1/2 (38 mm) minimum overlap of flue telescoping section is required.

Failure to maintain overlap may cause overheating and fire.

- Vent termination must not be recessed in the wall. Siding may be brought to the edge of the cap base.
- Flash and seal as appropriate for siding material at outside edges of cap.
- When installing a horizontal termination cap, follow the cap location guidelines as prescribed by current **ANSI Z223.1** and **CAN/CGA-B149** installation codes and refer to Section 6 of this manual.

CAUTION! Risk of Burns! Local codes may require installation of a cap shield to prevent anything or anyone from touching the hot cap.

Note: When using termination caps with factory-supplied heat shield attached, no additional wall shield firestop is required on the exterior side of a combustible wall.

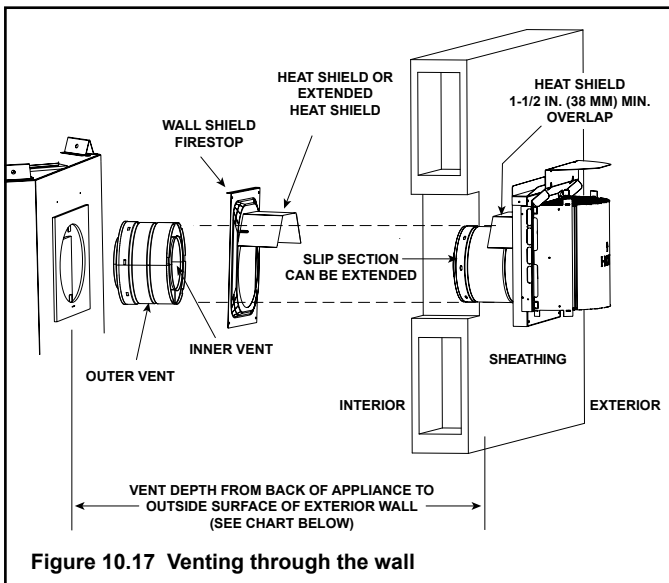

Cap Specification Chart
(depth without using additional pipe sections)

	DVP-TRAPK1	DVP-TRAP1	DVP-TRAPK2	DVP-TRAP2
	Top Vent Depth	Rear Vent Depth	Top Vent Depth	Rear Vent Depth
Cerona-36 Cerona-42	2-1/2 in. to 4-3/8 in.	N/A	5 in. to 9 in.	N/A
	DVP-HPC1	DVP-HPC1	DVP-HPC2	DVP-HPC2
	Top Vent Depth	Rear Vent Depth	Top Vent Depth	Rear Vent Depth
	2-1/2 in. to 4-5/8 in.	N/A	4-3/4 in. to 8-7/8 in.	N/A

DVP-TRAP1 can adjust 1-1/2 in. (3-1/8 to 4-5/8)

DVP-TRAP2 can adjust 4 in. (5-3/8 to 9-3/8)

DVP-HPC1 can adjust 2-1/8 in. (4-1/4 to 6-3/8)

DVP-HPC2 can adjust 4-1/8 in. (6-3/8 to 10-1/2)

11 Gas Information

A. Fuel Conversion

- Make sure the appliance is compatible with available gas types.
- Conversions must be made by a qualified service technician using Hearth & Home Technologies specified and approved parts.

B. Gas Pressure

- Optimum appliance performance requires proper input pressures.
- Gas line sizing requirements will be determined in ANSI Z223.1 National Fuel Gas Code in the USA and CAN/CGA B149 in Canada.
- Pressure requirements are:

Pressure	Natural Gas	Propane
Minimum inlet pressure	5.0 inches w.c.	11.0 inches w.c.
Maximum inlet gas pressure	14.0 inches w.c.	14.0 inches w.c.
Manifold pressure	3.5 inches w.c.	10.0 inches w.c.

WARNING! Risk of Fire or Explosion! High pressure will damage valve. Low pressure may cause explosion.

- Verify inlet pressures. Verify minimum pressures when other household gas appliances are operating.
- Install regulator upstream of valve if line pressure is greater than 1/2 psig.

⚠ WARNING



Fire Risk.
Explosion Hazard.
High pressure will damage valve.

- Disconnect gas supply piping BEFORE pressure testing gas line at test pressures above 1/2 psig.
- Close the manual shutoff valve BEFORE pressure testing gas line at test pressures equal to or less than 1/2 psig.

Note: Have the gas supply line installed in accordance with local codes, if any. If not, follow ANSI 223.1. Installation should be done by a qualified installer approved and/or licensed as required by the locality. (In the Commonwealth of Massachusetts installation must be performed by a licensed plumber or gas fitter).

Note: A listed (and Commonwealth of Massachusetts approved) 1/2 in. (13 mm) T-handle manual shut-off valve and flexible gas connector are connected to the 1/2 in. (13 mm) control valve inlet.

- **If substituting for these components, please consult local codes for compliance.**

C. Gas Connection

- Refer to Reference Section 16 for location of gas line access in appliance.
- Gas line may be run through knockout(s) provided.
- The gap between supply piping and gas access hole may be caulked with caulk with a minimum of 300°F continuous exposure rating or stuffed with non-combustible, unfaced insulation to prevent cold air infiltration.
- Ensure that gas line does not come in contact with outer wrap of the appliance. Follow local codes.
- Pipe incoming gas line into valve compartment.
- Connect incoming gas line to the 1/2 in. (13 mm) connection on manual shutoff valve.

WARNING! Risk of Fire or Explosion! Support control when attaching pipe to prevent bending gas line.

- A small amount of air will be in the gas supply lines.

WARNING! Risk of Fire or Explosion! Gas build-up during line purge could ignite.

- Purge should be performed by qualified service technician.
- Ensure adequate ventilation.
- Ensure there are no ignition sources such as sparks or open flames.

Light the appliance. It will take a short time for air to purge from lines. When purging is complete the appliance will light and operate normally.

WARNING! Risk of Fire, Explosion or Asphyxiation! Check all fittings and connections with a non-corrosive commercially available leak-check solution. **DO NOT** use open flame. Fittings and connections could have loosened during shipping and handling.

WARNING! Risk of Fire! DO NOT change valve settings. This valve has been preset at the factory.

D. High Altitude Installations

NOTICE: If the heating value of the gas has been reduced, these rules do not apply. Check with your local gas utility or authorities having jurisdiction.

When installing above 2000 feet elevation:

- In the USA: Reduce burner orifice 4% for each 1000 feet above 2000 feet.
- In CANADA: Reduce burner orifice 10% for elevations between 2000 feet and 4500 feet. Above 4500 feet, consult local gas utility.

12 Electrical Information

A. Wiring Requirements

NOTICE: This appliance must be electrically wired and grounded in accordance with local codes or, in the absence of local codes, with **National Electric Code ANSI/NFPA 70-latest edition or the Canadian Electric Code CSA C22.1.**

- Wire the appliance junction box to 110-120 VAC. This is required for proper operation of the appliance.
- A 110-120 VAC circuit for this product must be protected with ground-fault circuit-interrupter protection, in compliance with the applicable electrical codes, when it is installed in locations such as in bathrooms or near sinks.
- Low voltage and 110-120 VAC voltage cannot be shared within the same wall box.

WARNING! Risk of Shock or Explosion! DO NOT wire 110V to the valve or to the appliance wall switch. Incorrect wiring will damage controls.

B. Connecting to the Appliance

	<p>⚠ WARNING</p> <p>Wire 110V to electrical junction box. Do NOT wire 110- 120 VAC to valve. Do NOT wire 110- 120 VAC to wall switch.</p> <ul style="list-style-type: none">• Incorrect wiring will damage millivolt valves.• Incorrect wiring will override IPI safety lockout and may cause explosion.
--	--

Wall Switch

This appliance comes standard with a multi-function wall switch installed in the unit. A bag containing the wall switch, cover plate and flame control solenoid is located in the manual bag assembly on the right side of unit. Follow the “Determine Location” and “Wiring the Wall Switch” sections of the WSK-MLT instructions. Install the flame control solenoid by following Steps 5 - 11 in the “Installing the Control Box” section of the WSK-MLT instructions. You must also carefully follow the “Setting Flame Height/ Manifold Pressure” section of the included instructions to properly set the valve pressure. Operating instructions are also included in the WSK-MLT instructions.

- Use the wire provided with this product to connect the wall switch to the receiver, as outlined in the WSK-MLT instructions.
- Keep wire lengths short as possible by removing any excess wire length.
- Low voltage and 110-120 VAC voltage cannot be shared within the same wall box.

C. Intellifire Ignition System Wiring

This appliance requires a 110-120 VAC supply to the appliance junction box for operation. A wiring diagram is shown in Figure 12.1.

WARNING! Risk of Shock or Explosion! DO NOT wire IPI controlled appliance junction box to a switched circuit. Incorrect wiring will override IPI safety lockout.

This appliance is equipped with an Intellifire control valve which operates on a 3 volt system.

This appliance is supplied with a battery pack and a 3 volt AC transformer, which requires the installation of the supplied junction box. It is highly recommended that the junction box be installed at this time to avoid reconstruction.

NOTICE: Batteries should not be placed in the battery pack while using the transformer. Remove batteries before using the transformer, and unplug the transformer before installing the batteries. Battery polarity must be correct or module damage will occur.

D. Optional Accessories Requirements

Wiring for optional Hearth & Home Technologies approved accessories should be done now to avoid reconstruction. Follow instructions that come with those accessories.

E. Electrical Service and Repair

WARNING! Risk of Shock! Label all wires prior to disconnection when servicing controls. Wiring errors can cause improper and dangerous operation. Verify proper operation after servicing.

WARNING! Risk of Shock! Replace damaged wire with type 105° C rated wire. Wire must have high temperature insulation.

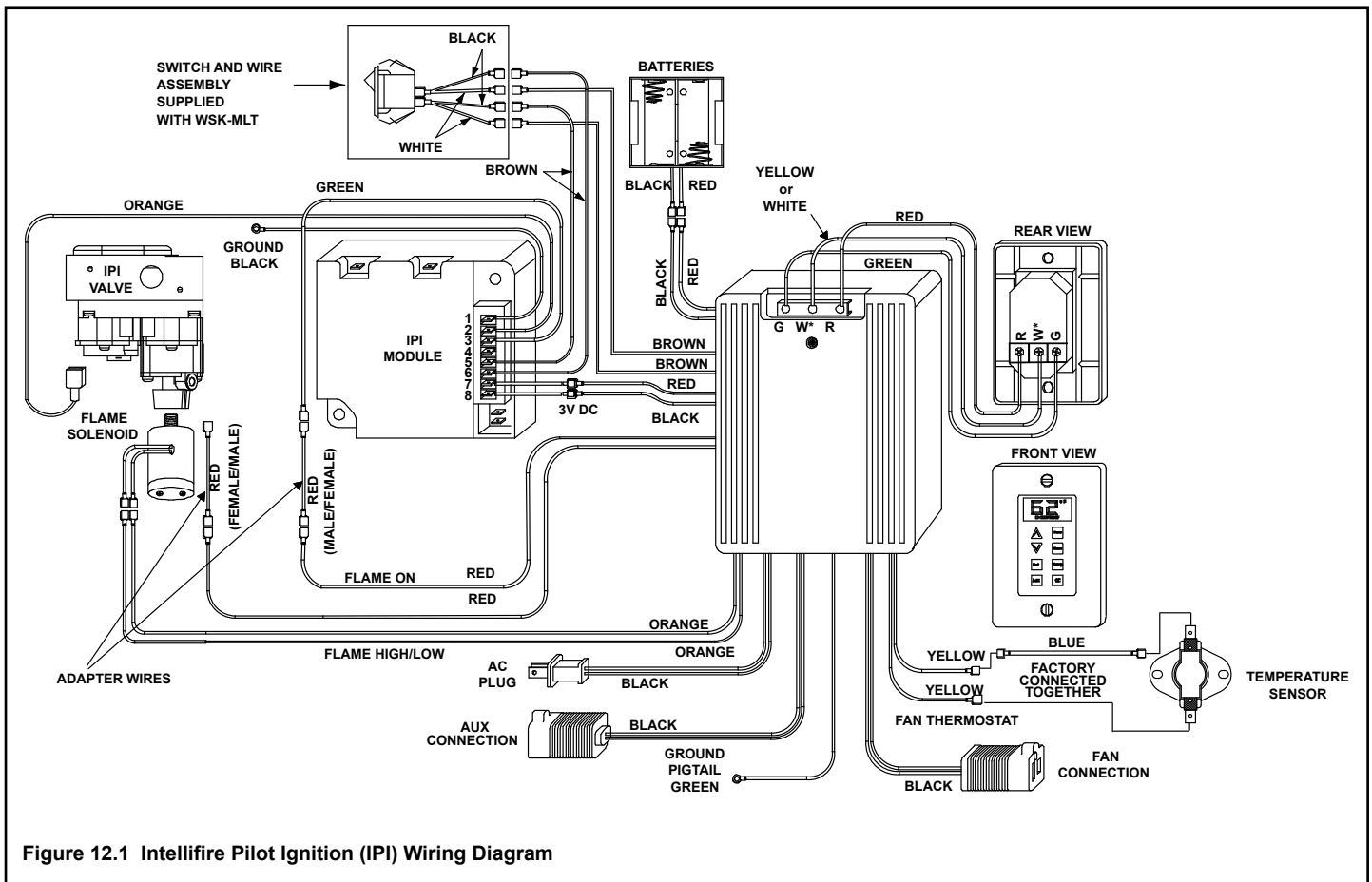

Figure 12.1 Intellifire Pilot Ignition (IPI) Wiring Diagram

F. Junction Box Installation

- Remove the screw attaching the junction box to the outer shell, rotate the junction box inward to disengage it from the outer shell (see Figure 12.2).
- Loosen the screw on the Romex connector, feed the necessary length of wire through the connector and tighten the screw.
- Pull the electrical wires from outside the appliance through this opening into the valve compartment.
- Make all necessary wire connections to the receptacle and assemble the receptacle and cover to the junction box.

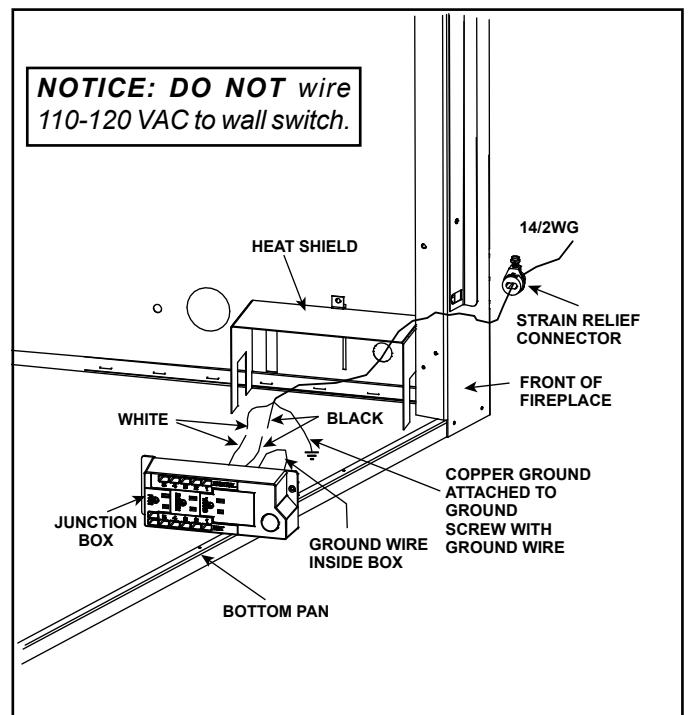

Figure 12.2 Junction Box Detail

13 Finishing

A. Splatter Guard

The splatter guard is a piece of corrugated material used to protect the appliance during the installation process before finishing work on the whole hearth is complete. Splatter guards may be factory installed or accompany the door of the unit, depending on the fireplace model. Splatter guards must be removed before appliance is fired.

WARNING! Risk of Fire! Close the ball valve before installing the splatter guard to prevent accidental lighting. Remove the splatter guard before lighting the appliance.

Step 1. Turn off gas to valve. Red gas shutoff knob is located on ball valve. Disconnect the 3 volt transformer from the junction box. See Figure 13.1.

To protect appliance after installation, but before use, please replace corrugated splatterguard on unit per directions noted below.

STEP 1

For Cerona-36, center left to right over glass and fold top center section under top heat shield as in figure 1. For Cerona-42, center left to right over glass and fold top three center sections under top heat shield.



Figure 13.1.

STEP 2

On the Cerona-36 model, place outside tabs over top heat shield and behind arched opening. For Cerona-42, place outer left and right tabs over top heat shield and behind arched opening. Figure 13.2 illustrates placement of outer center section and outer tabs over and under top heat shield on Cerona-42. The splatter guard must be inserted until tabs are engaged behind arched steel opening for both models.



Figure 13.2.

STEP 3

Push in folded bottom tab over control module heat shield, placing lower outside notches on glass support brackets. See Figure 13.3 and 13.4.



Figure 13.3.



Figure 13.4.

B. Mantel Projections

Figure 13.5 shows the minimum vertical and corresponding maximum horizontal dimensions of appliance mantels or other combustible projections above the top front edge of the appliance.

WARNING! Risk of Fire! Comply with all minimum clearances as specified. Framing closer than the minimums listed must be constructed entirely of non-combustible materials (i.e., steel studs, concrete board, etc.).

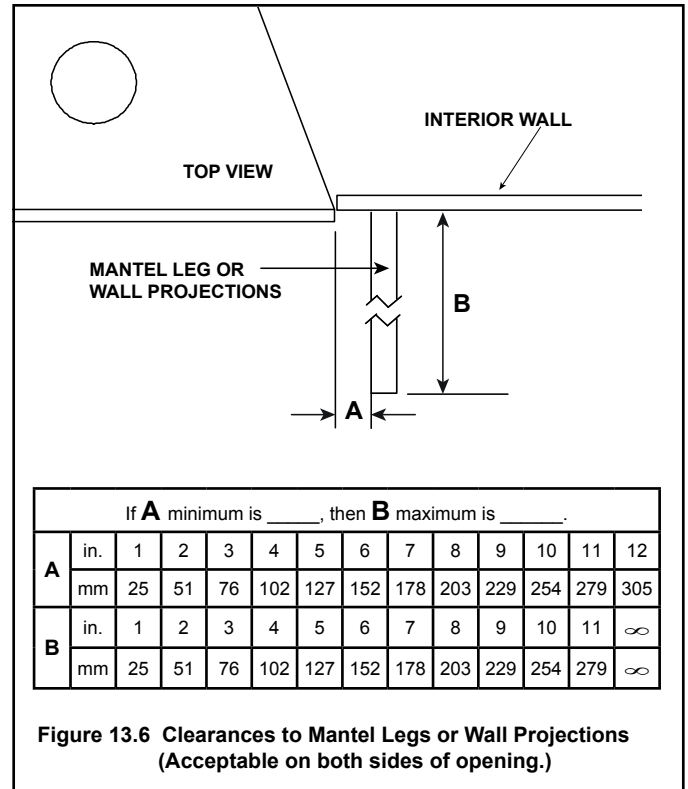
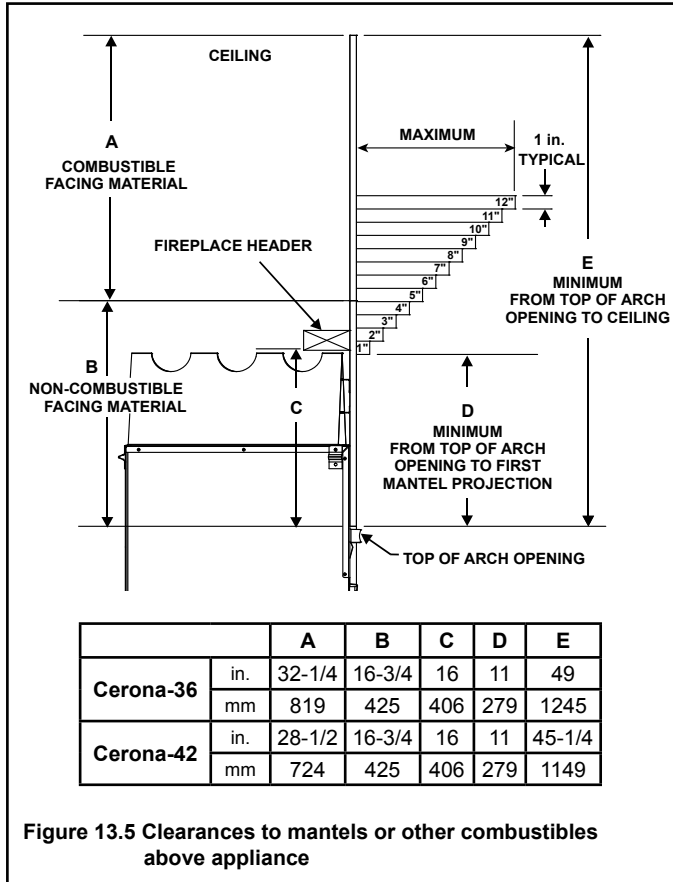

Figure 13.6 Clearances to Mantel Legs or Wall Projections (Acceptable on both sides of opening.)

C. Facing Material

WARNING! Risk of Fire!

DO NOT obstruct air inlet or outlet grilles.

DO NOT modify grilles.

- Modifying or covering grilles could cause temperature rise and fire hazard.

Finishing materials must not interfere with:

- Air flow through grilles or louvers.
- Operation of louvers or doors.
- Access for service.

WARNING! Risk of Fire!

Finish all edges and fronts to clearances and specifications listed in manual.

- Black metal appliance front may be covered with noncombustible material only.
- **DO NOT** overlap combustible materials onto appliance front.
- Install combustible materials only up to specified clearances on top, front and side.
- Seal joints between the finished wall and appliance top and sides using only a 300°F minimum sealant.

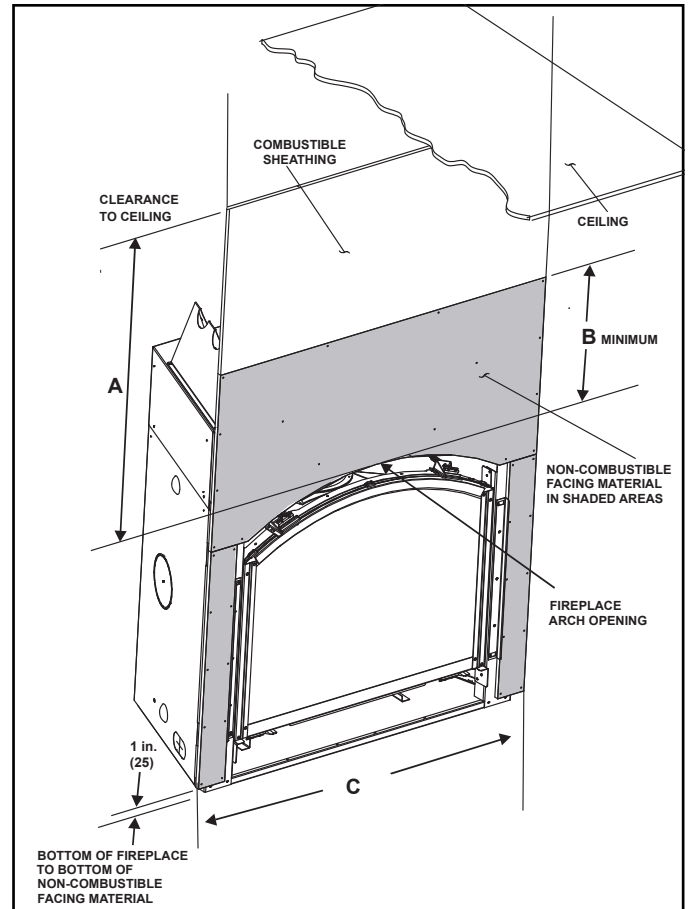

		A	B	C
Cerona-36	in.	49	16-3/4	43-5/8
	mm	1245	425	1108
Cerona-42	in.	45-1/4	16-3/4	50-5/8
	mm	1149	425	1286

Figure 13.8

Note: If using the Apollo Mantel System, the appliance must be raised 1-1/4 in. from floor.

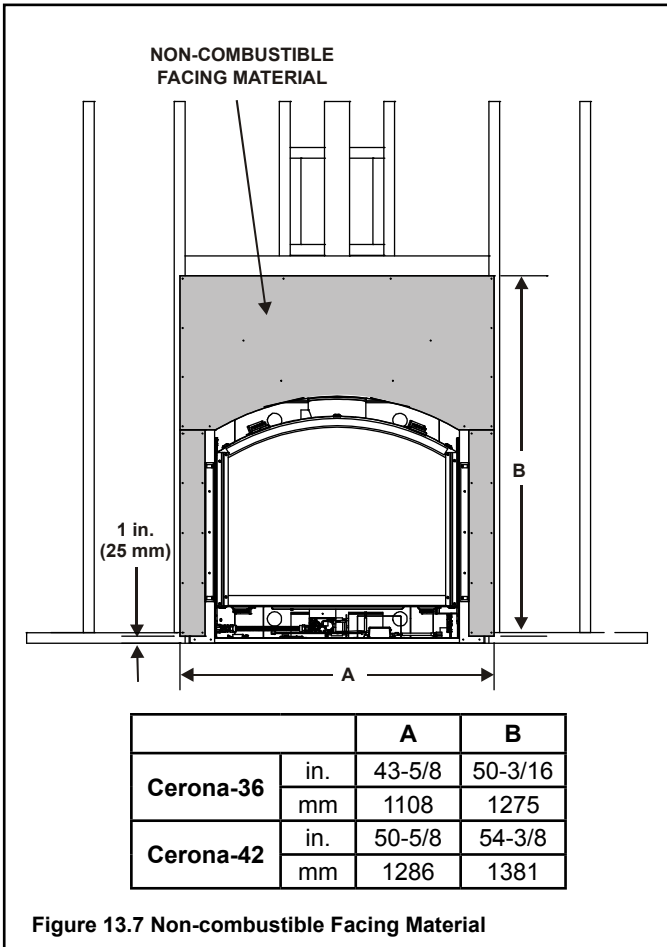

Figure 13.7 Non-combustible Facing Material

⚠ WARNING



Risk of Fire



- Non-combustible clearances **MUST** be maintained.
- Sheetrock, wood or other combustibles must **NOT** be used as sheathing or facing in the non-combustible zone.
- See **Section 11** for proper clearances.
- See **Section 1** for combustible/non-combustible definitions.

D. Finishing Material Options

Finishing Material Thickness from 3/4 in. to 1-1/4 in.

Finishing material within this thickness range can be brought to 1/2 inch behind the door top and sides. These non-combustible finishing materials must never overlap or obstruct the air outlet/inlet grille areas.

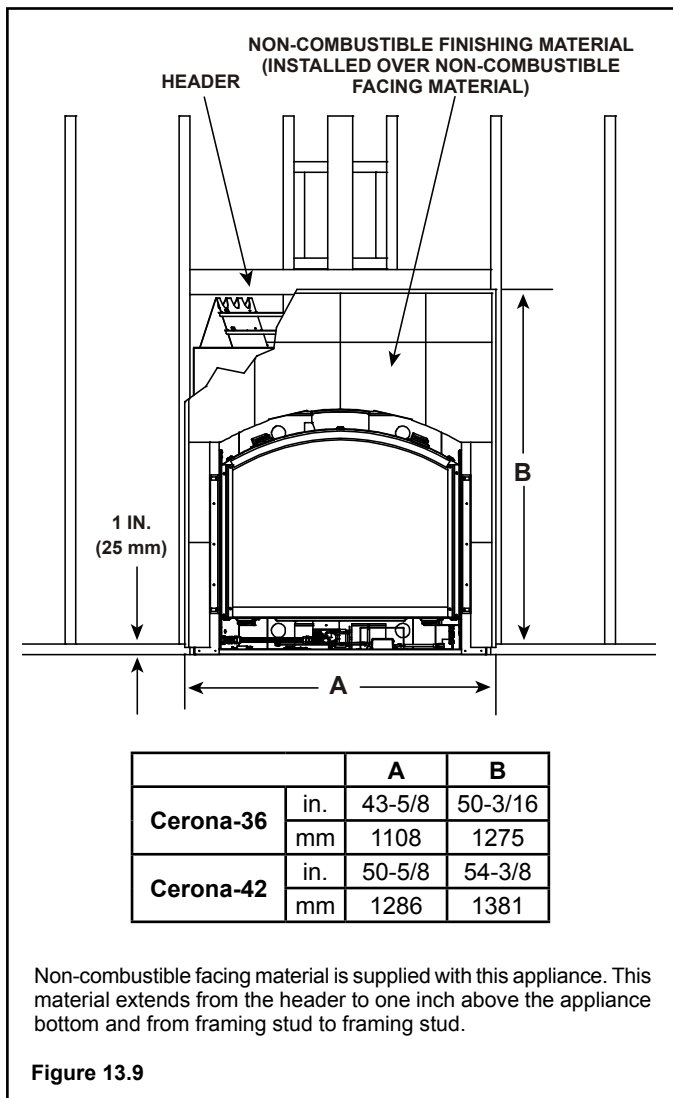

IMPORTANT INSTALLATION

Note: Please note that there are four holes or dots on the template to assist in positioning the template. These holes or dots should line up with the door mounting holes on the unit to ensure proper placement of the door after finishing materials are installed.

Finishing Material Thickness greater than 1-1/4 inch

A steel template (Cerona-36 Template or Cerona-42 Template) is available for purchase to use instead of constructing a template.

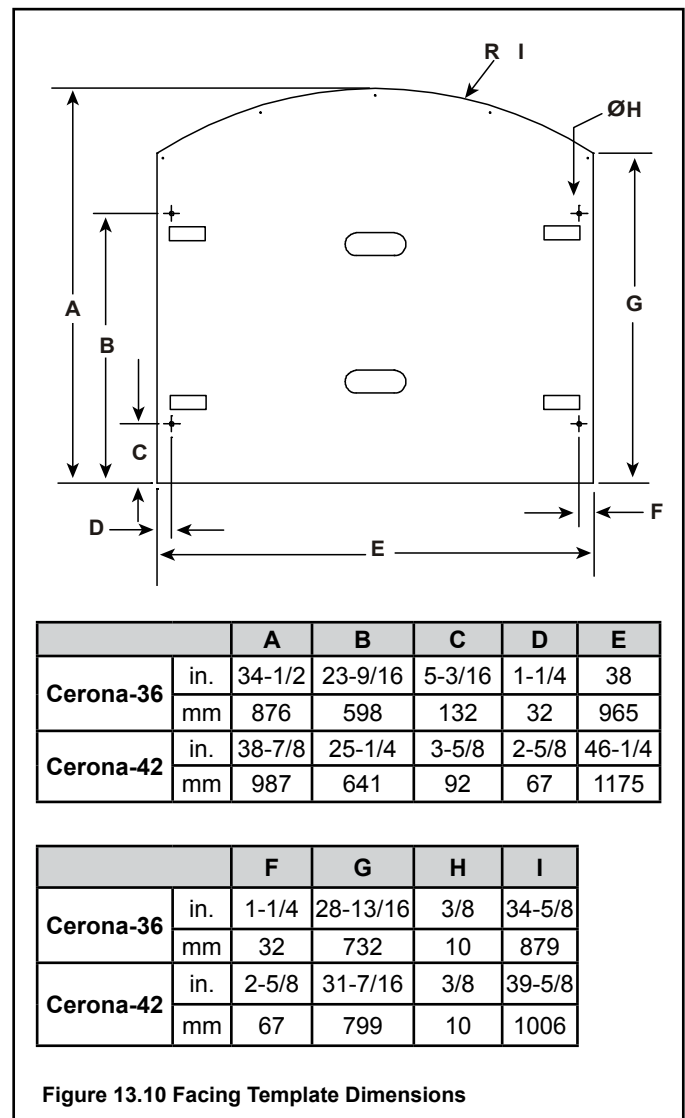

Mounting stone eye brow: ATRIMSTONE-36, ATRIMSTONE-42

Note: When mounting ATRIMSTONE-36 OR ATRIMSTONE-42 you must install template or front to insure proper positioning. Failure to do so will result in the front not fitting (see Figure 13.9).

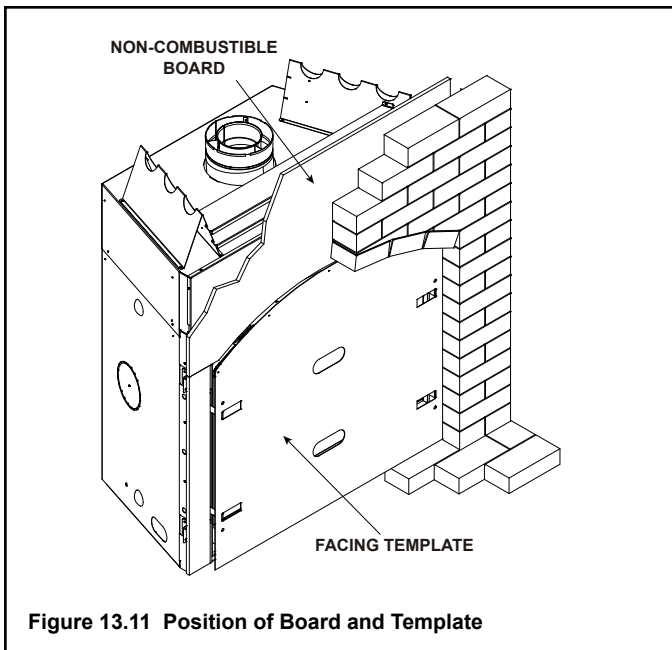

Figure 13.11 Position of Board and Template

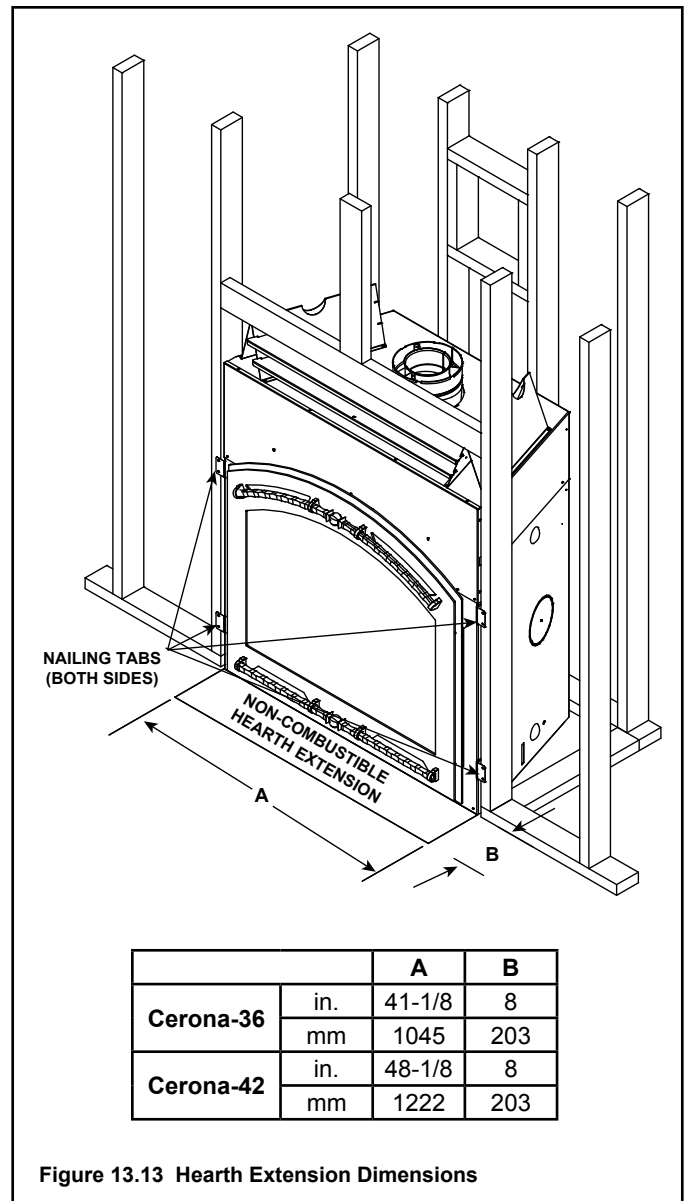

Figure 13.13 Hearth Extension Dimensions

E. Hearth Extension

⚠ WARNING



Fire Risk.

Hearth extension required to protect combustible floors in front of appliance.

- An 8 inch minimum hearth extension must be constructed of non-combustible material.

The base of the fireplace may sit on a combustible surface. The area in front of the fireplace must be protected by a noncombustible hearth extension, unless the fireplace is raised a minimum of 6 inches above the combustible floor or hearth. See Figures 13.12, 13.13 and 13.14.

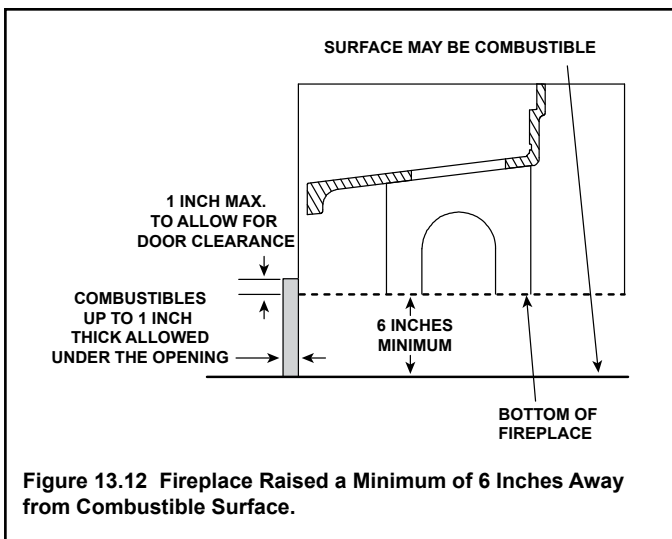

Figure 13.12 Fireplace Raised a Minimum of 6 Inches Away from Combustible Surface.

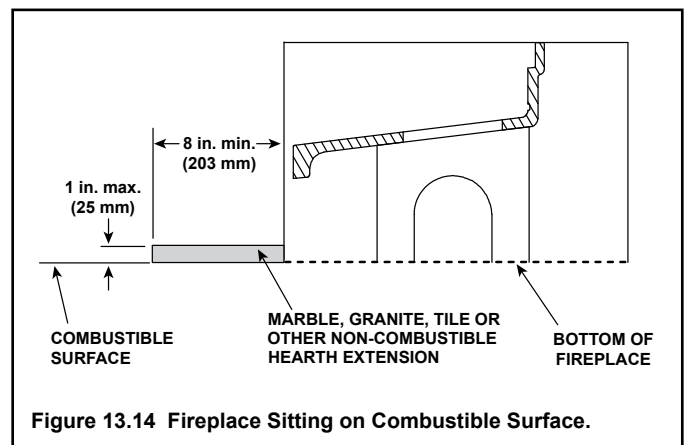

Figure 13.14 Fireplace Sitting on Combustible Surface.

14 Appliance Setup

A. Remove Fixed Glass Assembly

See Section 14.G.

B. Remove the Shipping Materials

Remove shipping materials from inside or underneath the firebox.

→ C. Inspect Firebox

Surface cracking or crazing of firebrick material is normal and expected. All cracks are acceptable and do not require replacement of the unit or the firebox with the exception of:

- Cracks compromising the surface plane of the firebox. See Figure 14.1.

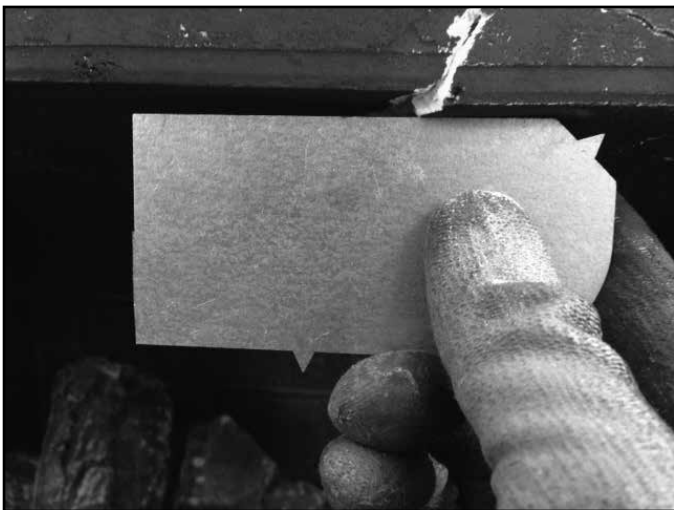

Figure 14.1 Surface plane of firebox is comprised and should be replaced.

D. Clean the Appliance

Clean/vacuum any sawdust that may have accumulated inside the firebox or underneath in the control cavity.

E. Accessories

Install approved accessories per instructions included with accessories. Contact your dealer for a list of approved accessories.

WARNING! Risk of Fire and Electric Shock! Use ONLY Hearth & Home Technologies-approved optional accessories with this appliance. Using non-listed accessories could result in a safety hazard and will void the warranty.

F. Ember Placement

WARNING! Risk of Explosion! Follow ember placement instructions in manual. DO NOT place embers directly over burner ports. Replace ember material annually. Improperly placed embers interfere with proper burner operation.

Ember material is shipped with this gas appliance. To place the ember material:

- There are two types of ember shipped with the appliance. Embers for the burner surface and Mystic Embers for the floor of the appliance.
- Embers CANNOT be placed directly over ports. Care should be taken not to cover the lighting trail of ports (from back to front).
- When placing Glowing Embers® onto the burner care should be taken so that the ports are not covered. Place the dime-size ember pieces in front and behind of the port trail, but not on or in between the ports (see Figure 14.2). Failure to follow procedure will likely cause lighting and sooting problems.
- Place Mystic Embers on areas of base refractory away from port holes. Use this material to give the appliance a realistic ash bed.
- Save the remaining ember materials for use during appliance servicing. The embers provided should be enough for 3 to 5 applications.

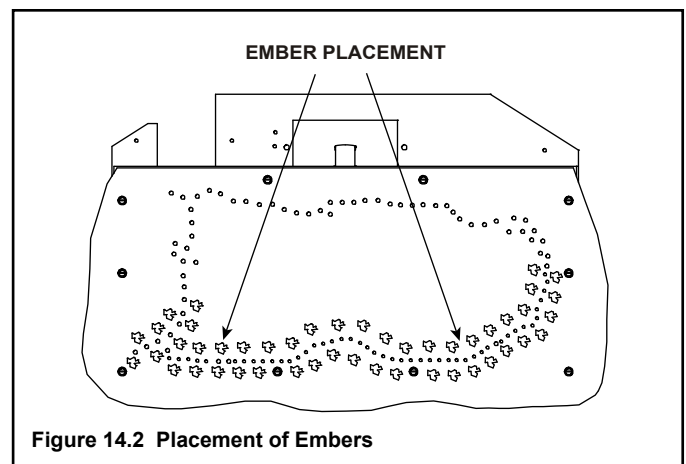

Figure 14.2 Placement of Embers

G. Positioning the Logs

Log Assembly: LOGS-Cerona36

Model: Cerona-36

If the gas logs have been factory installed they should not need to be positioned. If the logs have been packaged separately, refer to the following instructions.



Figure 1

CAUTION: Carefully remove the logs from the packaging. Logs are fragile!



Figure 2

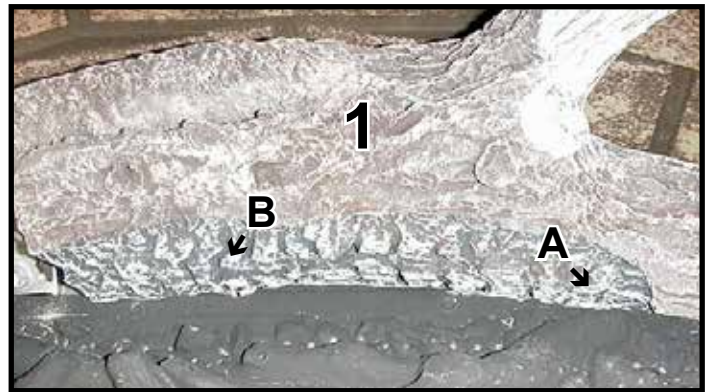

Figure 3

STEP 1. LOG #1 (SRV2106-701): Place the notch on the left underside of log #1, over the log tab that is located on the right side of the pilot bracket (B). Move the right end of log #1 forward until it hits the stick on the burner (A). The closer the log is to the burner the more glow you will get. Don't place the log too close to the burner or sooting may occur.

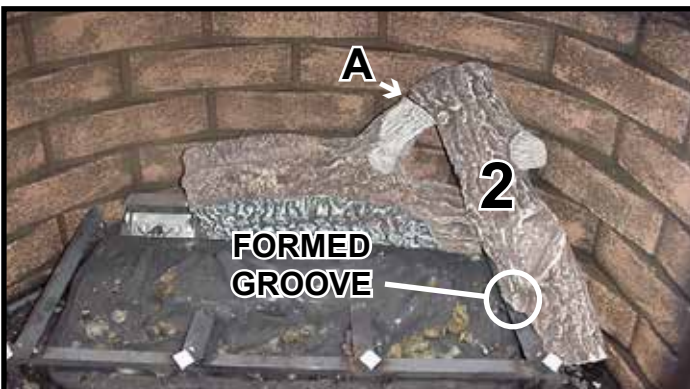

Figure 4

STEP 2. LOG #2 (SRV2106-703): Fit log #2 on the top branch of log #1 (A). Rest the formed groove of the lower part of the log on the grate. It may be necessary to tilt Log #1 forward to properly engage with Log #2.



Figure 5

STEP 3. LOG #3 (SRV2106-705): Place the "Y" portion of the log in the grate tine and rest the log on the formed portion of log #2.

2106-935B



Figure 6

STEP 4. LOG #4 (SRV2106-704): Log #4 is form fitted to the burner. It sits on the middle portion of the burner as shown. Logs should sit flush to burner with no gaps between log and burner.



Figure 7

STEP 5. LOG #5 (SRV2106-702): Place the right portion of log #5 on the formed area of log #1. Place the left side on the grate. Set the notch of the log on the grate.

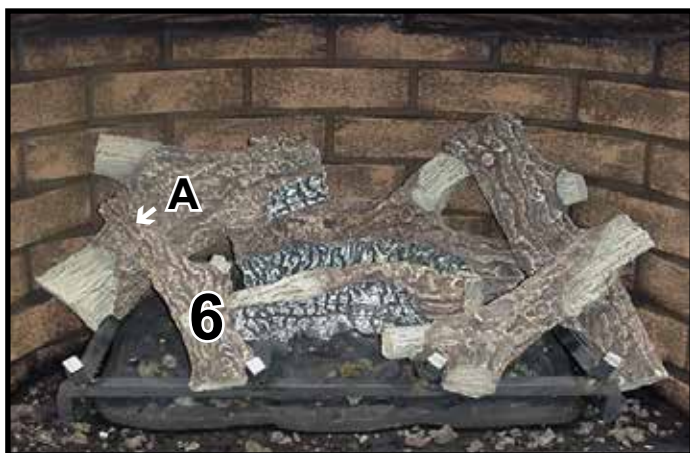

Figure 8

STEP 6. LOG #6 (SRV2106-706): Rest bottom notch of log #6 on the grate tine and the top part on formed section of log #5 (A).

Model: Cerona-42

Log Assembly: LOGS-Cerona42

If the gas logs have been factory installed they should not need to be positioned. If the logs have been packaged separately, refer to the following instructions.

CAUTION: Carefully remove the logs from the packaging. Logs are fragile!

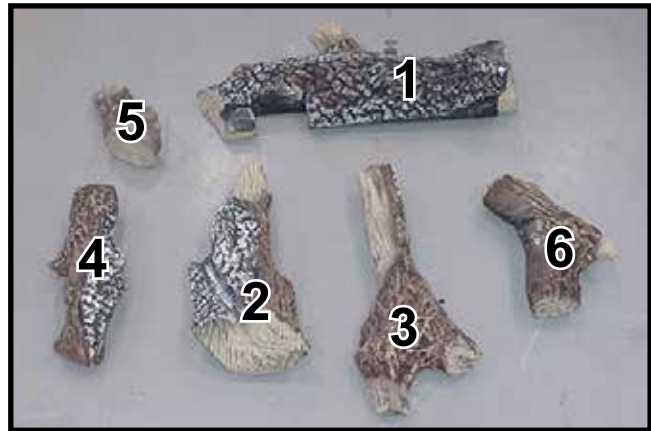

Figure 1

STEP 1. LOG #1 (SRV2107-701):

Place log #1 over the back side of the burner plate and slide forward until log hits the grate. Log cut out should fit over pilot bracket. See Figure 2.



Figure 2

STEP 2. LOG #2 (SRV2107-702):

Fit log #2 on the right side of the grate. The log is formed so it will sit around the right grate bar. Rest the top of the log on the flat section of log #1. See Figure 3.



Figure 3

STEP 3.

LOG #3 (SRV2107-703):

Place the notch on the tip of log #3 over the locating tab on log #1. Place the left leg of the log on the far left grate tine (A). See Figure 4.

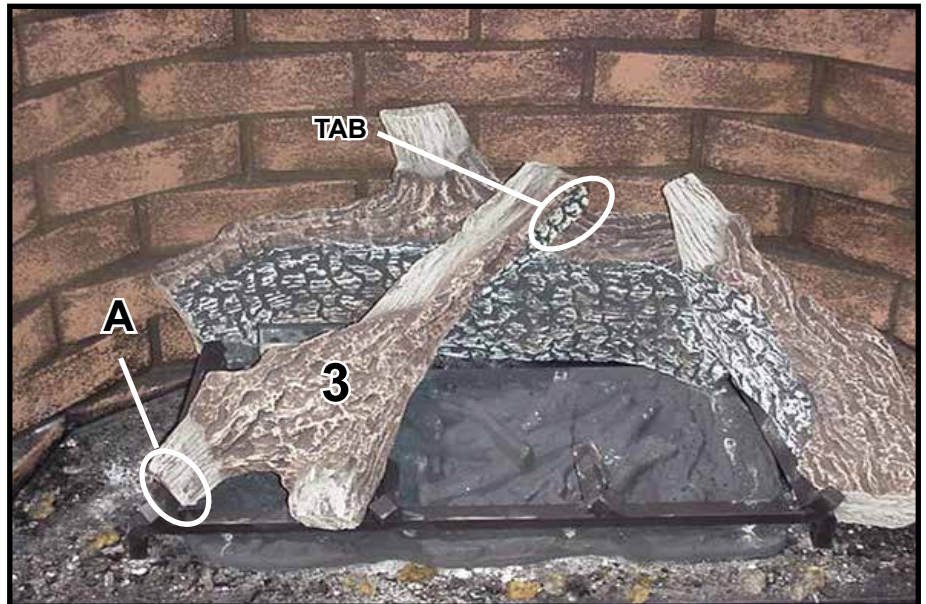

Figure 4.

STEP 4.

LOG #4 (SRV2107-704):

Place the left formed end of log #4 on the burner detail located under log #3, and the notch on the right end of log #4 on the front grate bar. Log #3 may need to be adjusted for proper placement. See Figure 5.

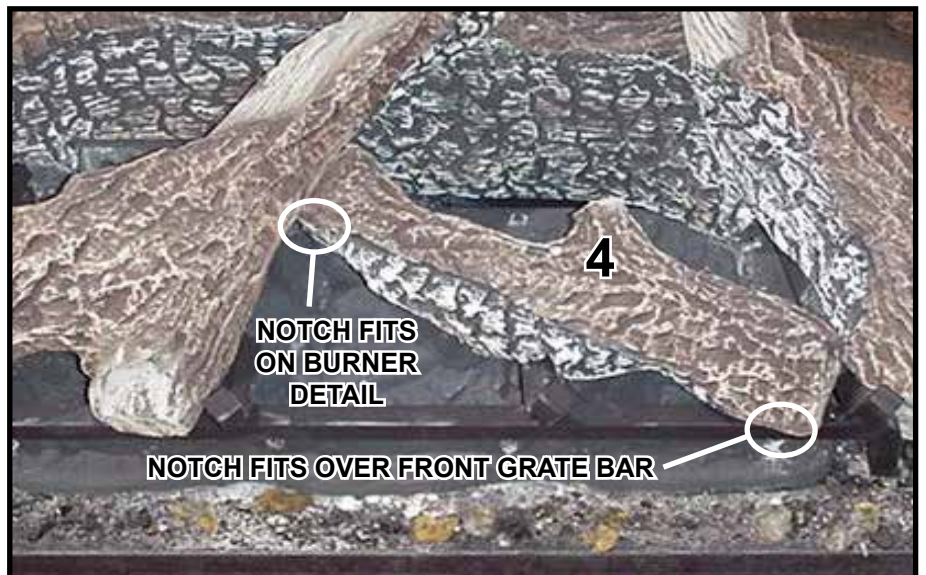

Figure 5.

STEP 5.

LOG #5 (SRV2107-705):

Place log #5 on the left side between the grate tine and firebox. **Note:** This log will be used to support log #6. See Figure 6.



Figure 6.

STEP 7.

LOG #6 (SRV2107-706):

Place notch of log #6 over the left grate tine. Log should rest on the flat of log #5 and the flat on log #3. You may need to reposition log #5 to get log #6 to sit in the flats. See Figure 7.



Figure 7

H. Fixed Glass Assembly

WARNING! Risk of Asphyxiation! Handle fixed glass assembly with care. Inspect the gasket to ensure it is undamaged and inspect the glass for cracks, chips or scratches.

- **DO NOT** strike, slam or scratch glass.
- **DO NOT** operate fireplace with glass removed, cracked, broken or scratched.
- Replace as a complete assembly.

Removing Fixed Glass Assembly

Pull the four glass assembly latches out of the groove on the glass frame. Remove glass door from the appliance (see Figure 14.2).

Replace the glass door on the appliance. Pull out and latch the four glass assembly latches into the groove on the glass frame.

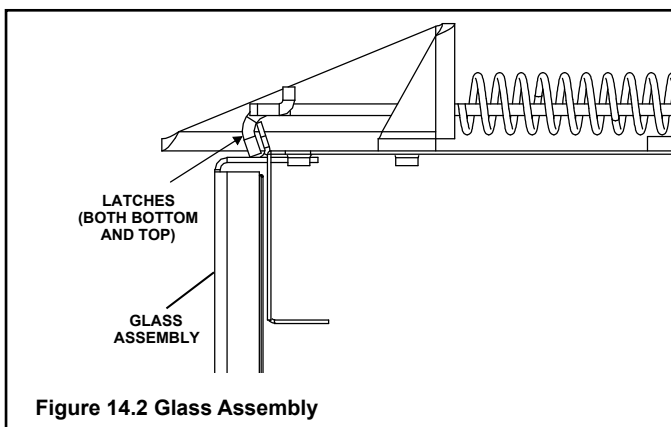

Figure 14.2 Glass Assembly

I. Grilles and Trim

Install optional marble and brass trim surround kits as desired. Marble, brass, brick, tile, or other noncombustible materials can be used to cover up the gap between the sheet rock and the appliance.

Do not obstruct or modify the air inlet/outlet grilles. When overlapping on both sides, leave enough space so that the bottom grille can be lowered and the trim door removed.

J. Air Shutter Setting

Air shutter settings should be adjusted by a qualified service technician at the time of installation. The air shutter is set at the factory for minimum vertical vent run. Adjust air shutter for longer vertical runs. See Figure 14.3.

- Loosen the wing nut.
- Pull the air shutter forward to close the air shutter.
- Push the air shutter backward to open the air shutter.
- Tighten the wing nut.

NOTICE: If sooting occurs, provide more air by opening the air shutter.

Shutter Settings

Burner	NG	LP
Cerona-36	Full Open	Full Open
Cerona-42	Full Open	Full Open

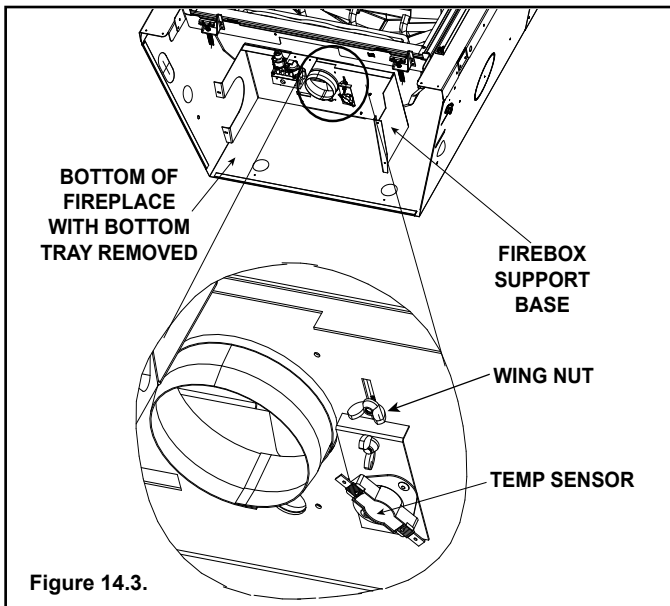

K. Install Mesh

- This model requires a door or decorative front. Mesh is included with all available decorative fronts.

L. Install Trim and/or Surround

- Install optional trim kits and/or surrounds using the instructions included with the accessory.
- Use non-combustible materials to cover the gap between the sheet rock and the appliance (when applicable to the model).

15 Troubleshooting

With proper installation, operation, and maintenance your gas appliance will provide years of trouble-free service. If you do experience a problem, this troubleshooting guide will assist a qualified service technician in the diagnosis of a problem and the corrective action to be taken. This troubleshooting guide can only be used by a qualified service technician. Contact your dealer to arrange a service call by a qualified service technician.

A. Intellifire Ignition System

Symptom	Possible Cause	Corrective Action
1. Pilot won't light. The ignitor/module makes noise, but no spark.	A. Incorrect wiring.	Verify "S" wire (white) for sensor and "I" wire (orange) for ignitor are connected to correct terminals on module and pilot assembly.
	B. Loose connections or electrical shorts in the wiring.	Verify no loose connections or electrical shorts in wiring from module to pilot assembly. Verify connections underneath pilot assembly are tight; also verify connections are not grounding out to metal chassis, pilot burner, pilot enclosure, mesh screen if present, or any other metal object.
	C. Ignitor gap is too large.	Verify gap of igniter to right side of pilot hood. The gap should be approximately .17 in. or 1/8 in. (3 mm).
	D. Module.	Turn ON/OFF rocker switch or wall switch to OFF position. Remove ignitor wire "I" from module. Place a grounded wire about 3/16 in. (5 mm) away from "I" terminal on module. Place ON/OFF rocker switch or wall switch in ON position. If there is no spark at "I" terminal module must be replaced. If there is a spark at "I" terminal, module is fine. Inspect pilot assembly for shorted sparker wire or cracked insulator around electrode. Replace pilot if necessary.
2. Pilot won't light, there is no noise or spark.	A. No power or transformer installed incorrectly.	Verify that transformer is installed and plugged into module. Check voltage of transformer under load at spade connection on module with ON/OFF switch in ON position. Acceptable readings of a good transformer are between 3.2 and 2.8 volts AC.
	B. A shorted or loose connection in wiring configuration or wiring harness.	Remove and reinstall the wiring harness that plugs into module. Verify there is a tight fit. Verify pilot assembly wiring to module. Remove and verify continuity of each wire in wiring harness. Replace any damaged components.
	C. Improper wall switch wiring.	Verify that 110/120 VAC power is "ON" to junction box.
	D. Module not grounded.	Verify black ground wire from module wire harness is grounded to metal chassis of appliance.
	E. Module.	Turn ON/OFF rocker switch or wall switch to OFF position. Remove ignitor wire "I" from module. Place ON/OFF rocker switch or wall switch in ON position. If there is no spark at "I" terminal module must be replaced. If there is a spark at "I" terminal, module is fine. Inspect pilot assembly for shorted sparker wire or cracked insulator around electrode.
3. Pilot sparks, but Pilot will not light.	A. Gas supply.	Verify that incoming gas line ball valve is "open". Verify that inlet pressure reading is within acceptable limits.
	B. Ignitor gap is too large.	Verify gap of igniter to right side of pilot hood. The gap should be approximately .17 in. or 1/8 in. (3 mm).
	C. Module is not grounded.	Verify module is securely grounded to metal chassis of appliance.
	D. Module voltage output / Valve/Pilot solenoid ohms readings.	Verify battery voltage is at least 2.7 volts. Replace batteries if voltage is below 2.7.

Intellifire Ignition System - (continued)

Symptom	Possible Cause	Corrective Action
<p>4. Pilot lights but continues to spark, and main burner will not ignite. (If the pilot continues to spark after the pilot flame has been lit, flame rectification has not occurred.)</p>	<p>A. A shorted or loose connection in flame sensing rod.</p>	<p>Verify all connections to wiring diagram in manual. Verify connections underneath pilot assembly are tight. Verify connections are not grounding out to metal chassis, pilot burner, pilot enclosure or screen if present, or any other metal object.</p>
	<p>B. Poor flame rectification or contaminated flame sensing rod.</p>	<p>With fixed glass assembly in place, verify that flame is engulfing flame sensing rod on left side of pilot hood. Flame sensing rod should glow shortly after ignition. Verify correct pilot orifice is installed and gas inlet is set to pressure specifications. Polish flame-sensing rod with fine steel wool to remove any contaminants that may have accumulated on flame sensing rod.</p>
	<p>C. Module is not grounded.</p>	<p>Verify module is securely grounded to metal chassis of appliance. Verify that wire harness is firmly connected to the module.</p>
	<p>D. Damaged pilot assembly or contaminated flame sensing rod.</p>	<p>Verify that ceramic insulator around the flame sensing rod is not cracked, damaged, or loose. Verify connection from flame sensing rod to white sensor wire. Polish flame-sensing rod with fine steel wool to remove any contaminants that may have accumulated on flame sensing rod. Verify continuity with a multimeter with ohms set at lowest range. Replace pilot if any damage is detected.</p>
	<p>E. Module.</p>	<p>Turn ON/OFF rocker switch or wall switch to OFF position. Remove ignitor wire "I" from module. Place ON/OFF rocker switch or wall switch in ON position. If there is no spark at "I" terminal module must be replaced. If there is a spark at "I" terminal, module is fine.</p>

16 Reference Materials

A. Appliance Dimension Diagram

Dimensions are actual appliance dimensions. Use for reference only. For framing dimensions and clearances refer to Section 5.

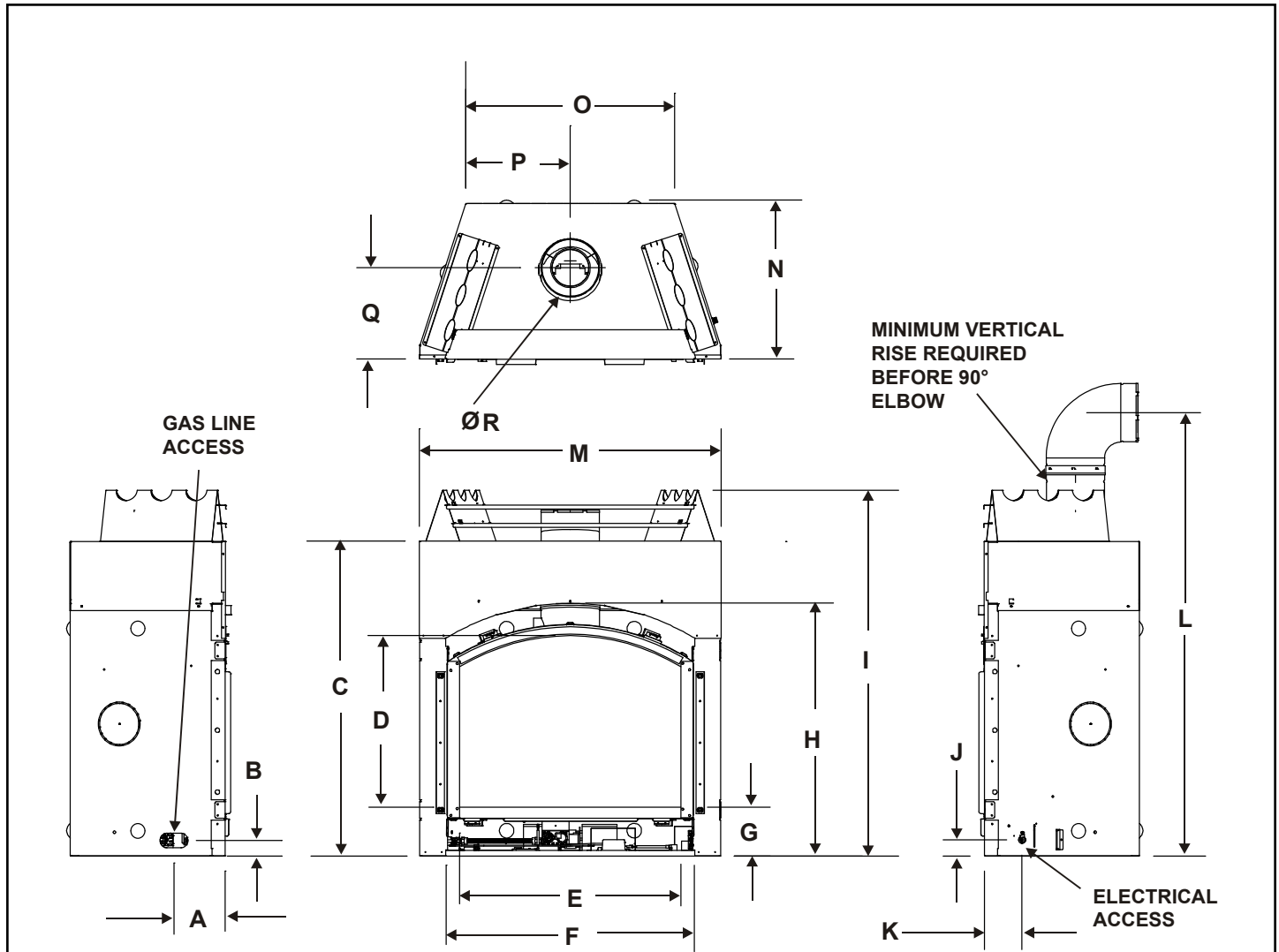

Model: Cerona-36

Inches	Millimeter	
A	7	178
B	2-1/8	54
C	43	1092
D	23-1/2	595
E	30-1/4	767
F	33-7/8	860
G	6-5/8	169
H	34-1/2	877
I	49-7/8	1268

Model: Cerona-42

Inches	Millimeter	
J	2-1/4	56
K	5-1/8	130
L	60-1/2	1537
M	41-1/8	1046
N	21-3/4	551
O	28-1/2	724
P	14-1/4	362
Q	12-1/2	316
R	8	204

Inches	Millimeter	
A	9-1/4	235
B	2-1/4	56
C	47-1/8	1196
D	27-3/4	704
E	35-7/8	912
F	39-1/2	1005
G	6-3/4	170
H	38-5/8	981
I	54	1372

Inches	Millimeter	
J	2-1/4	59
K	5-3/8	137
L	71	1803
M	48-1/8	1223
N	21-3/4	551
O	35-3/8	900
P	17-3/4	450
Q	12-5/8	319
R	8	204

Figure 16.1 Appliance Dimensions

B. Vent Components Diagrams

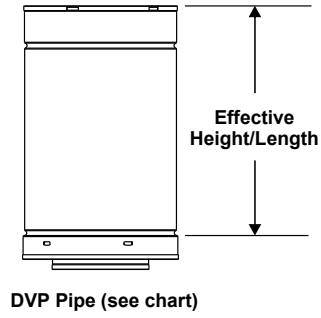

Pipe	Effective Length	
	Inches	Millimeters
DVP4	4	102
DVP6	6	152
DVP12	12	305
DVP24	24	610
DVP36	36	914
DVP48	48	1219
DVP6A	3 to 6	76 to 152
DVP12A	3 to 12	76 to 305

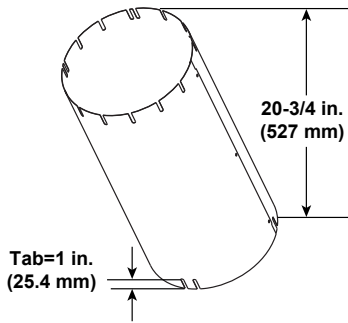
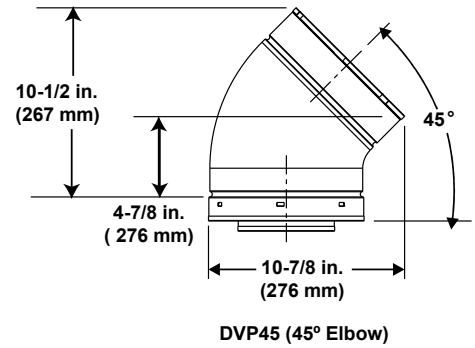

Finished Height: 19-3/4 in./502 mm
UNIV-AS2 (Attic Insulation Shield)

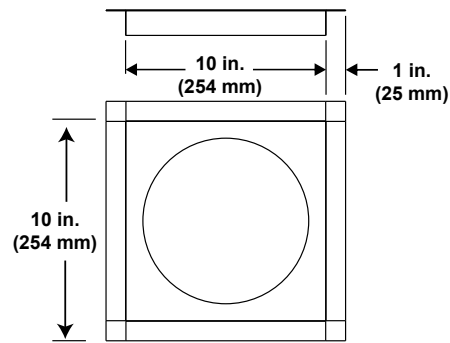

DVP-FS (Ceiling Firestop)

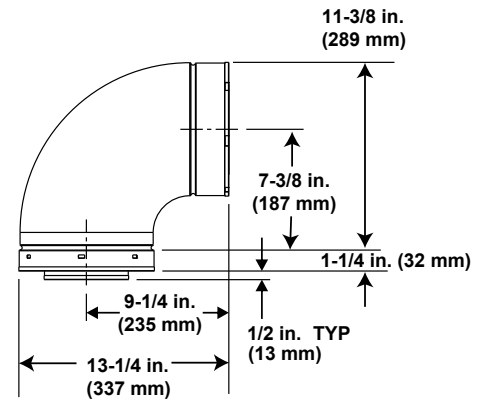

DVP90ST (90° Elbow)

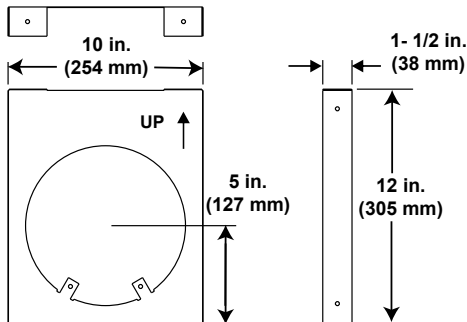

DVP-HVS (Vent Support)

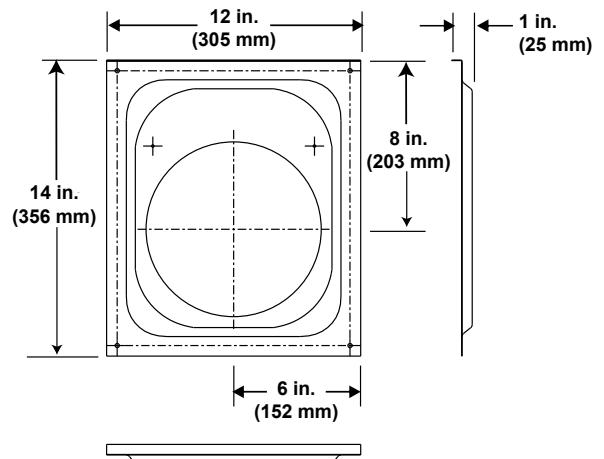

DVP-WS (Wall Shield Firestop)

Figure 16.2 DVP vent components

B. Vent Components Diagrams (continued)

Note: Heat shields MUST overlap by a minimum of 1-1/2 in. (38 mm). The heat shield is designed to be used on a wall 4 in. to 7-1/4 in. (102 mm to 184 mm) thick. If wall thickness is less than 4 in. (102 mm) the existing heat shields must be field trimmed. If wall thickness is greater than 7-1/4 in. (184 mm) a DVP-HSM-B will be required.

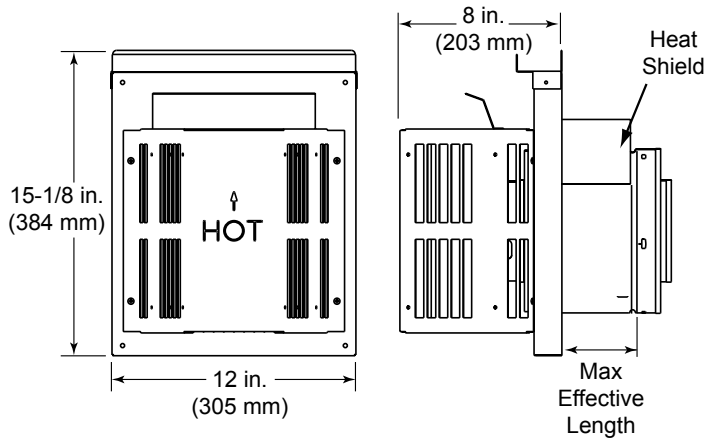

DVP-TRAP
Horizontal Termination Cap

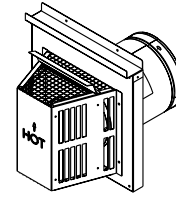

Term Cap	Minimum Effective Length	Maximum Effective Length
Trap1	3-1/8 in.	4-5/8 in.
	79 mm	117 mm
Trap2	5-3/8 in.	9-3/8 in.
	137 mm	238 mm

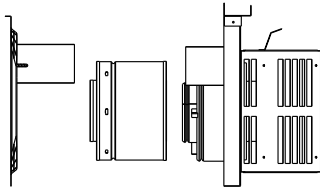

DVP-TRAP1

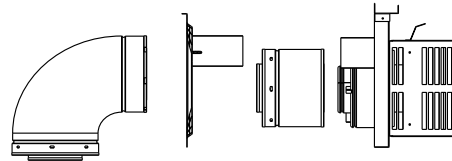

DVP-TRAPK1

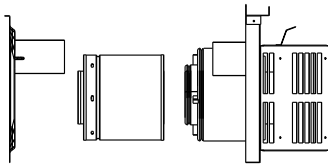

DVP-TRAP2

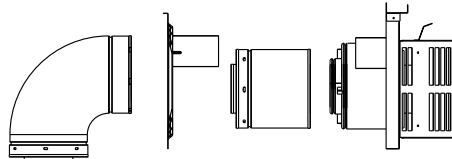

DVP-TRAPK2

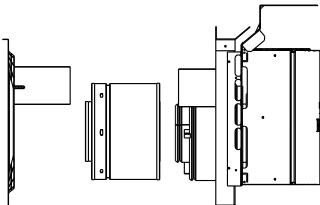

DVP-HPC1

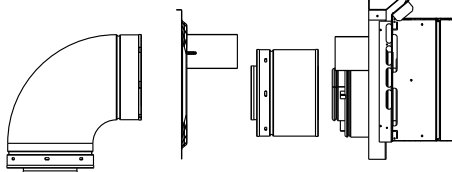

DVP-HPCK1-B

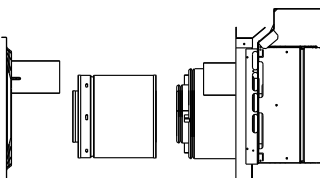

DVP-HPC2

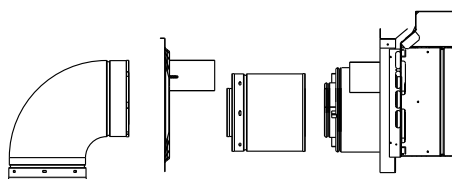

DVP-HPCK2-B

Figure 16.3 DVP vent components

B. Vent Components Diagrams (continued)

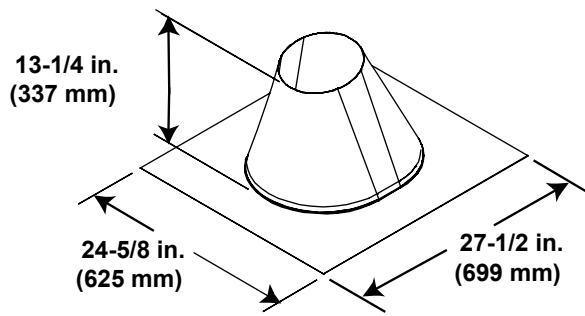

RF6M
Roof Flashing Multi-pak

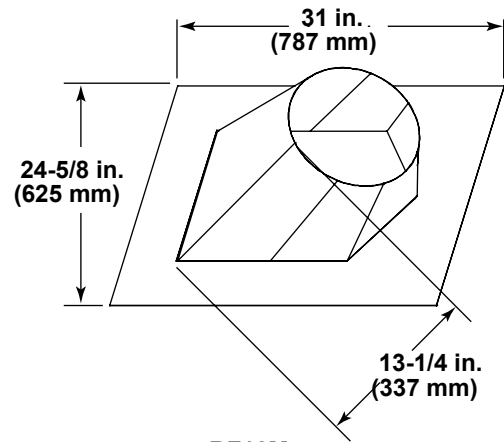

RF12M
Roof Flashing Multi-pak

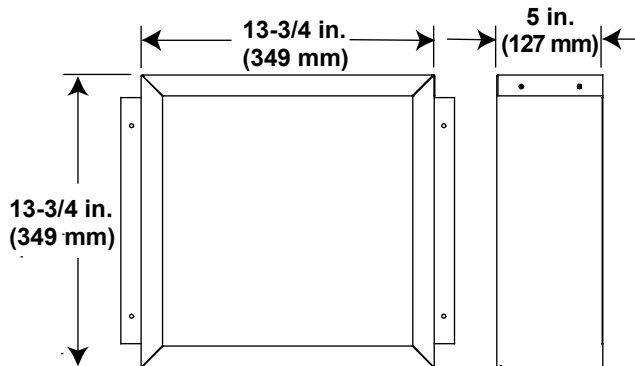

BEK
Trap Cap Brick Extension

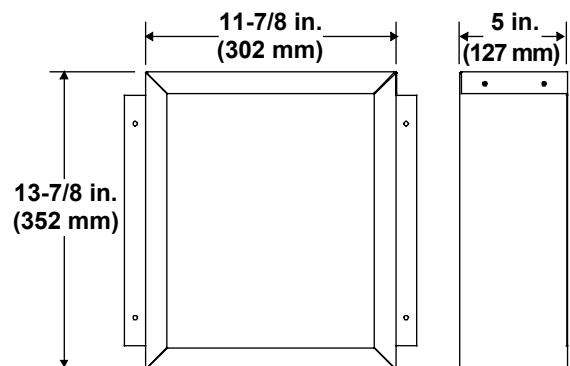

DVP-BEK2
DVP-HPC Cap Brick Extension

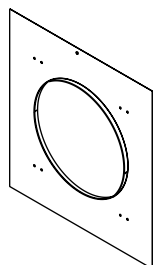

DVP-TRAPFL
Flashing

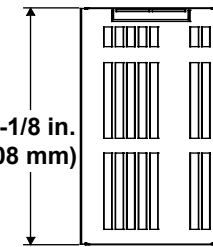
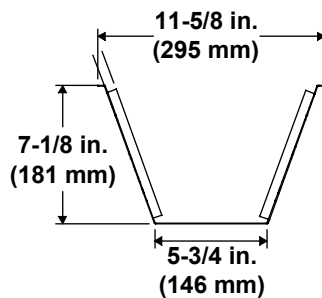

COOL-ADDM
Cap Shield

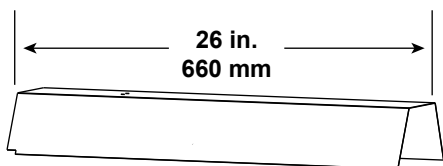
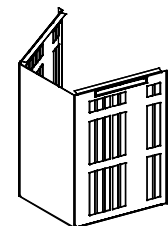

DVP-HSM-B
Extended Heat Shield

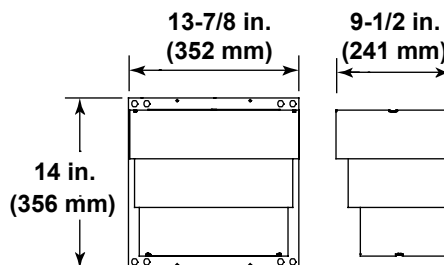

DRC-RADIUS
Cap Shield

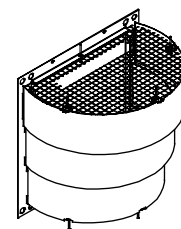

Figure 16.4 DVP vent components

B. Vent Components Diagrams (continued)

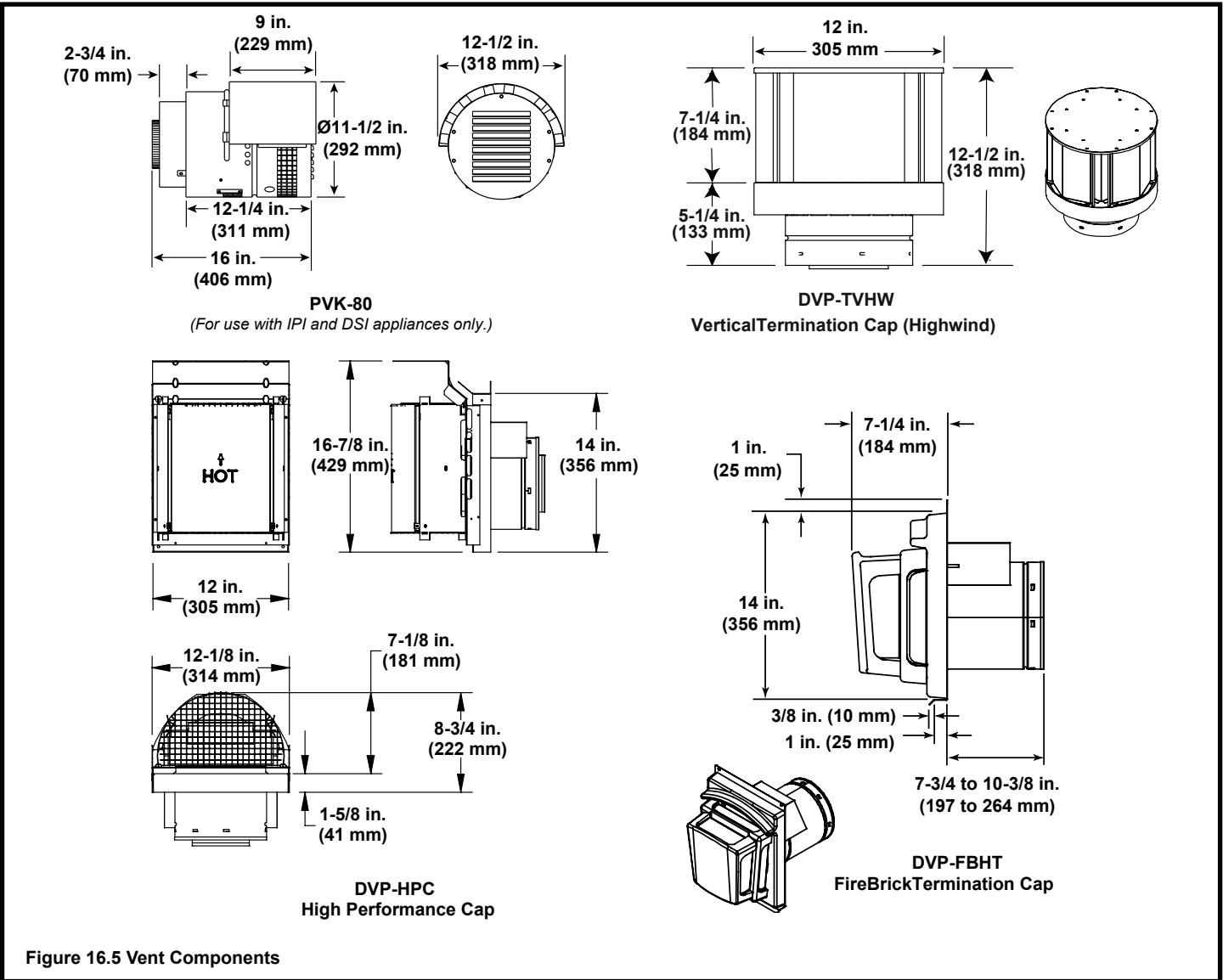
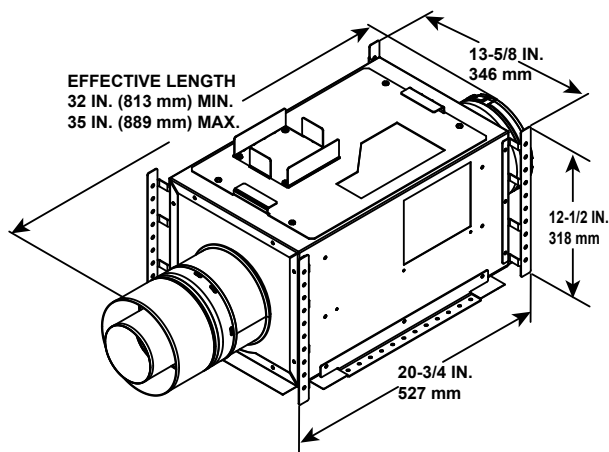

Figure 16.5 Vent Components



PVI-SLP
Power Vent Inline

Optional Wire Harness	
DESCRIPTION	PART NUMBER
10 ft. PV Wire Harness	PVI-WH10
20 ft. PV Wire Harness	PVI-WH20
40 ft. PV Wire Harness	PVI-WH40
60 ft. PV Wire Harness	PVI-WH60
80 ft. PV Wire Harness	PVI-WH80
100 ft. PV Wire Harness	PVI-WH100

Note: Wire harnesses required to power the PVI-SLP connect to the appliance and are ordered separately from PVI-SLP. Contact your dealer to order.

Note: Use only approved termination caps with the PVI-SLP. See instructions included with PVI-SLP kit.

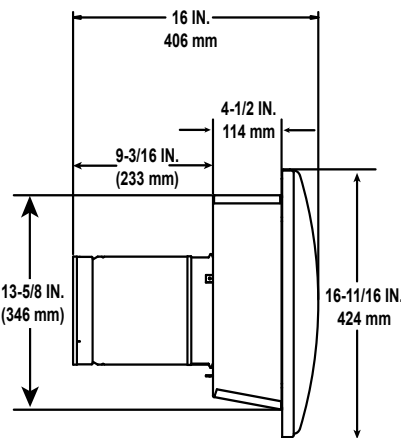
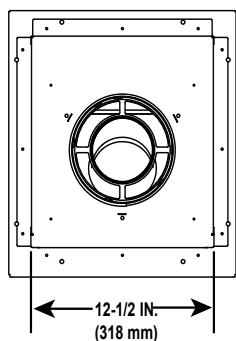

SLP-LPC
SLP Low Profile Cap

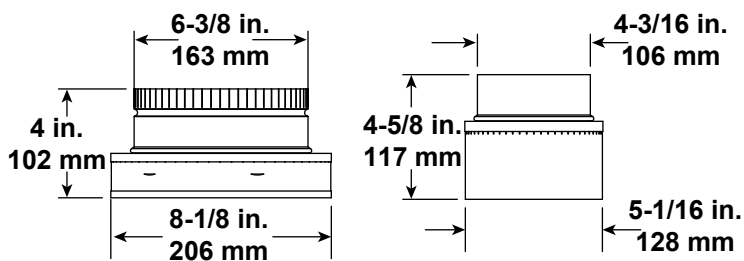
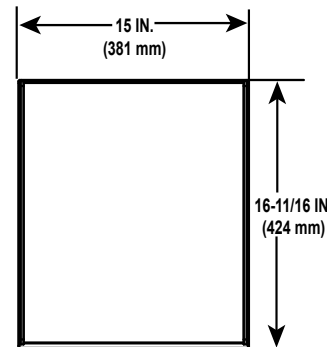

DVP-2SL
Adapter

Figure 16.6 Vent Components

Log Set Assembly

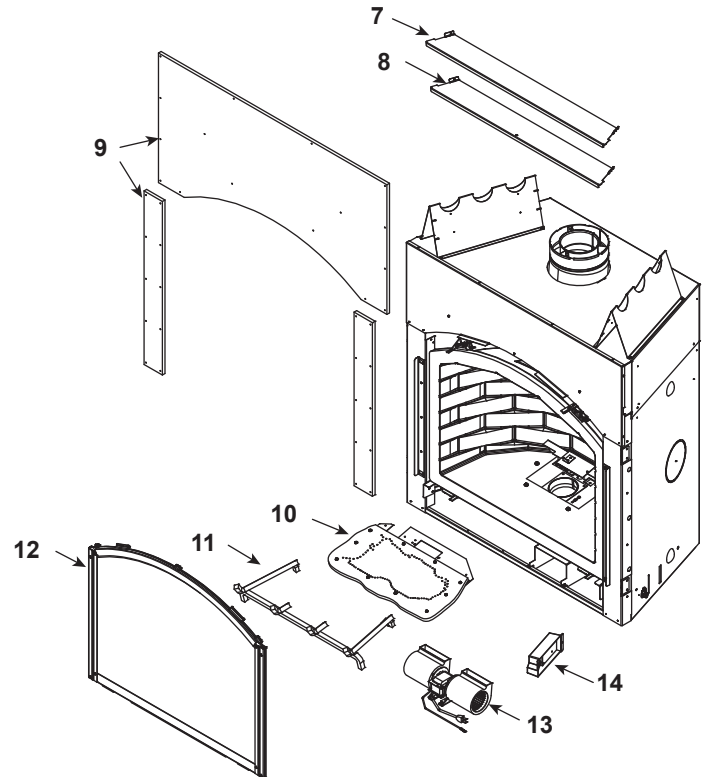
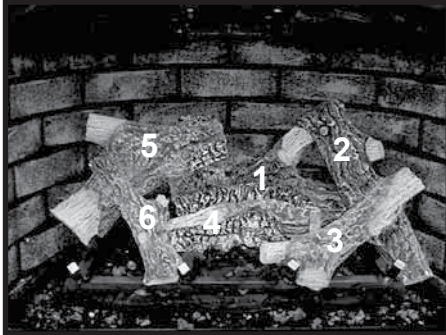

IMPORTANT: THIS IS DATED INFORMATION. Parts must be ordered from a dealer or distributor. **Hearth and Home Technologies does not sell directly to consumers.** Provide model number and serial number when requesting service parts from your dealer or distributor.



Stocked at Depot

ITEM	DESCRIPTION	COMMENTS	PART NUMBER	
	Log Set Assembly		LOGS-CERONA36	Y
1	Log 1		SRV2106-701	
2	Log 2		SRV2106-703	
3	Log 3		SRV2106-705	
4	Log 4		SRV2106-704	
5	Log 5		SRV2106-702	
6	Log 6		SRV2106-706	
7	Top Header Heat Shield		2106-144	
8	Bottom Header Heat Shield		2106-145	
9	Non-Combustible Board Assembly		2106-030	
10	Burner NG, LP		2106-003	Y
11	Grate Assembly		2106-006	
12	Glass Door Assembly		GLA-CERONA36	Y
13	Fan Kit		GFK-160A	
14	Junction Box		4021-013	Y
	Control Box	No longer available	2106-025	
		Post Sn #0021359350	WSK-MLT	

Additional service part numbers appear on following page.

8/14

Log Set Assembly

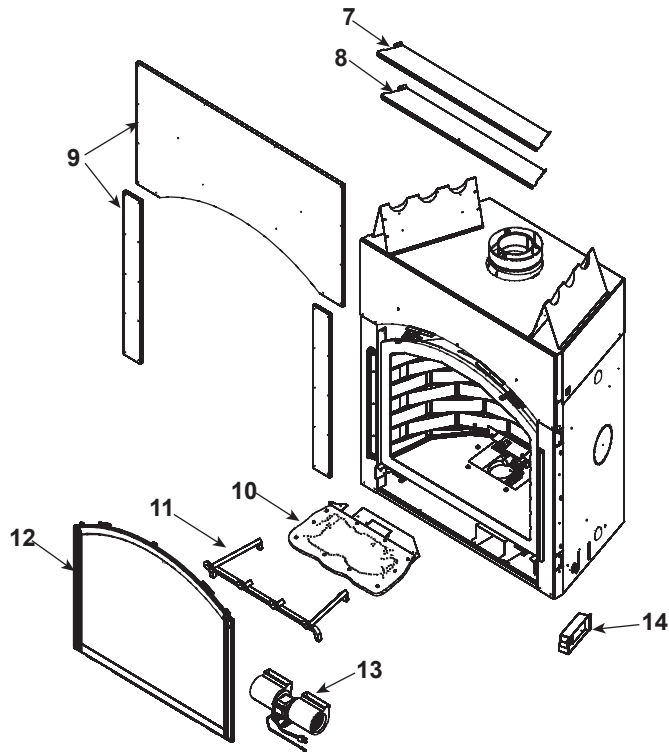

IMPORTANT: THIS IS DATED INFORMATION. Parts must be ordered from a dealer or distributor. **Hearth and Home Technologies does not sell directly to consumers.** Provide model number and serial number when requesting service parts from your dealer or distributor.



Stocked at Depot

ITEM	DESCRIPTION	COMMENTS	PART NUMBER	
	Log Set Assembly		LOGS-CERONA42	Y
1	Log 1		SRV2107-701	
2	Log 2		SRV2107-702	
3	Log 3		SRV2107-703	
4	Log 4		SRV2107-704	
5	Log 5		SRV2107-705	
6	Log 6		SRV2107-706	
7	Top Header Heat Shield		2107-144	
8	Bottom Header Heat Shield		2107-145	
9	Non-Combustible Board		2107-030	
10	Burner NG, LP		2107-003	Y
11	Grate Assembly		2106-006	
12	Glass Door Assembly		GLA-CERONA42	Y
13	Fan Kit		GFK-160A	
14	Junction Box		4021-013	Y
	Control Box	No longer available	2106-025	
		Post SN #0021359354	WSK-MLT	

Additional service part numbers appear on following page.

8/14

No one builds a better fire

#15 Valve Assembly

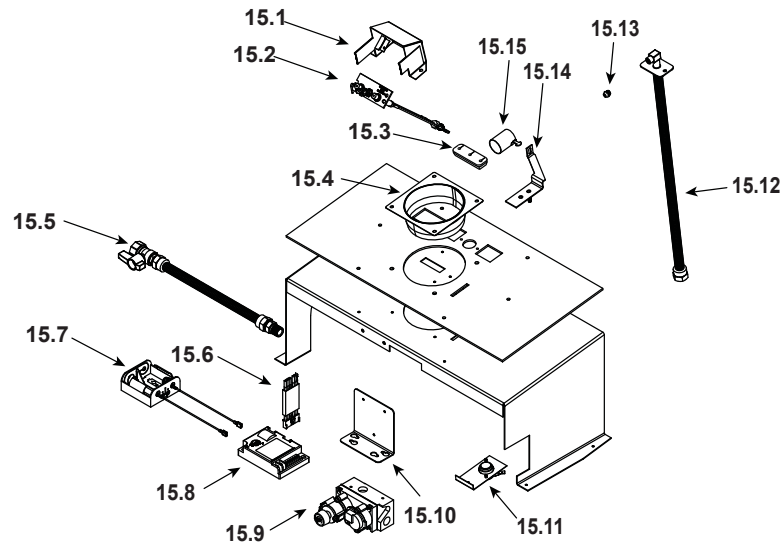

IMPORTANT: THIS IS DATED INFORMATION. Parts must be ordered from a dealer or distributor. **Hearth and Home Technologies does not sell directly to consumers.** Provide model number and serial number when requesting service parts from your dealer or distributor.



Stocked at Depot

ITEM	DESCRIPTION	COMMENTS	PART NUMBER	
15.1	Pilot Bracket		2106-135	
15.2	Pilot Assembly NG		2106-009	Y
	Pilot Assembly LP		2106-008	Y
15.3	3-Hole Grommet		2118-420	
15.4	Collar 4"		2081-140	
15.5	Flex Ball Valve Assembly		302-320A	Y
15.6	Module Wire Assembly		593-590A	Y
15.7	Battery Pack		593-594A	Y
15.8	Module		593-592	Y
15.9	Valve NG		750-500	Y
	Valve LP		750-501	Y
15.10	Valve Bracket		2106-107	
15.11	High Temp Limit Switch	Pre June 2009 must order both switch, Wire, and shutter Bracket assembly	2106-005 and 107-559A	Y
			2106-010(NG) or 2106-071(LP)	Y
		Post June 2009	2106-005	Y
15.12	Flexible Gas Connector		530-302A	Y
15.13	Orifice NG (#32)	Cerona-36	582-832	Y
	Orifice LP (#50)		583-829	Y
15.13	Orifice NG (#29)	Cerona-42	582-848	Y
	Orifice LP (#48)		582-850	Y
15.14	Shutter Bracket Assembly (NG)		2106-010	Y
	Shutter Bracket Assembly (LP)		2106-071	Y
15.15	Shutter Sleeve		2026-130	Y

Additional service part numbers appear on following page.

