

Installation Manual

Installation and Appliance Setup

INSTALLER: Leave this manual with party responsible for use and operation.

OWNER: Retain this manual for future reference.

NOTICE: DO NOT discard this manual!

HEAT & GLO™

No one builds a better fire

Models:
PRIMO48

PRIMO48ST

PRIMO60

PRIMO60ST

PRIMO72

PRIMO72ST

GAS-FIRED

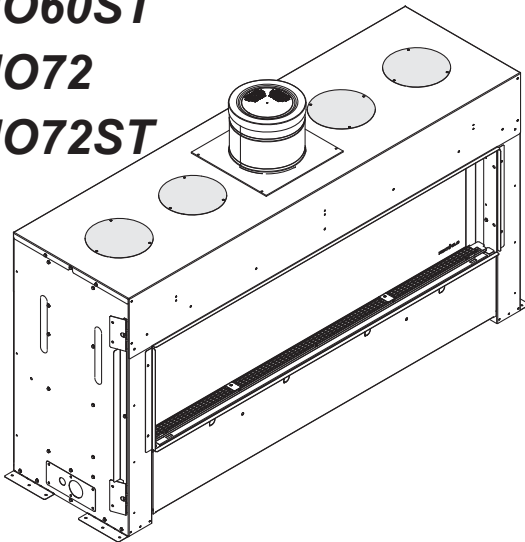

This appliance may be installed as an OEM installation in manufactured home (USA only) or mobile home and must be installed in accordance with the manufacturer's instructions and the *Manufactured Home Construction and Safety Standard, Title 24 CFR, Part 3280* in the United States, or the *Standard for Installation in Mobile Homes, CAN/CSA Z240 MH Series*, in Canada.

This appliance is only for use with the type(s) of gas indicated on the rating plate. This appliance is not convertible for use with other gases, unless a certified kit is used.

In the Commonwealth of Massachusetts installation must be performed by a licensed plumber or gas fitter.

See Table of Contents for location of additional Commonwealth of Massachusetts requirements.

⚠ WARNING:

FIRE OR EXPLOSION HAZARD

Failure to follow safety warnings exactly could result in serious injury, death, or property damage.

- **DO NOT** store or use gasoline or other flammable vapors and liquids in the vicinity of this or any other appliance.
- **What to do if you smell gas**
 - **DO NOT** try to light any appliance.
 - **DO NOT** touch any electrical switch. **DO NOT** use any phone in your building.
 - Leave the building immediately.
 - Immediately call your gas supplier from a neighbor's phone. Follow the gas supplier's instructions.
 - If you cannot reach your gas supplier, call the fire department.
- Installation and service must be performed by a qualified installer, service agency, or the gas supplier.

This appliance comes standard with patented SafeSurface™ Glass which keeps the surface temperature of the barrier glass at a safe level and will still be hot to the touch when operated for long periods of time. SafeSurface™ Glass complies with the barrier requirements of ANSI Z21.50-2014 CSA 2.22-2014 for vented gas fireplaces. If the barrier glass is removed, the inner glass temperature will be very hot and cause burns.

! DANGER



HOT GLASS WILL CAUSE BURNS.

DO NOT TOUCH GLASS UNTIL COOLED.

NEVER ALLOW CHILDREN TO TOUCH GLASS.

A (glass) barrier designed to reduce the risk of burns from the hot viewing glass is provided with this appliance and shall be installed for the protection of children and other at-risk individuals.

▲ Safety Alert Key:

- **DANGER!** Indicates a hazardous situation which, if not avoided will result in death or serious injury.
- **WARNING!** Indicates a hazardous situation which, if not avoided could result in death or serious injury.
- **CAUTION!** Indicates a hazardous situation which, if not avoided, could result in minor or moderate injury.
- **NOTICE:** Used to address practices not related to personal injury.

Table of Contents

→ Installation Standard Work Checklist	3
--	---

1 Product Specific and Important Safety Information

A. Appliance Certification	4
B. Glass Specifications	4
C. BTU Specifications	4
D. High Altitude Installations	4
E. Non-Combustible Materials Specification	5
F. Combustible Materials Specification	5
G. Electrical Codes	5
H. Requirements for the Commonwealth of Massachusetts	6

2 Getting Started

A. Design and Installation Considerations	7
B. Tools and Supplies Needed	7
C. Inspect Appliance and Components	7

3 Framing and Clearances

A. Appliance/Decorative Finish Dimension Diagrams	8
B. Clearances to Combustibles	12
C. Constructing the Appliance Chase	16
D. Floor Protection	16

4 Termination Location and Vent Information

A. Vent Termination Minimum Clearances PVI-SLP	17
B. Chimney Diagram	18
C. Approved Pipe	19
D. Use of Elbows	19
E. Measuring Standards	19
F. Vent System and Diagrams	19
G. Power Vent Baffle Adjustment	21

5 Vent Clearances and Framing

A. Pipe Clearances to Combustibles	22
B. Wall Penetration Framing/Firestops	23
C. Ceiling Firestop/Floor Penetration Framing	24
D. Install Attic Insulation Shield	24

6 Appliance Preparation

A. Vent Collar Preparation	25
B. Securing and Leveling the Appliance	26
→ C. HEAT-ZONE-PRIMO	27
→ D. HEAT-OUT-PRIMO	33
E. Burner Glass Installation	36

7 Venting and Chimneys

A. Assemble Vent Sections	37
B. Assemble Slip Sections	39
C. Secure the Vent Sections	39
D. Disassemble Vent Sections	40
E. Vertical Termination Requirements (PVI-SLP)	41
F. Horizontal Termination Requirements Heat Shield Requirements for Horizontal Termination (PVI-SLP)	42

8 Electrical Information

A. General Information	44
B. Wiring Requirements	47 ←

9 Gas Information

A. Fuel Conversion	49
B. Gas Pressure	49
C. Gas Service Access	50
D. Gas Connection	52
E. High Altitude Installations	53
F. Air Shutter Setting	53

10 Finishing

A. Facing and Finishing - General Information	54
B. Clean Face Finish (Black Glass Interior)	57
C. Black Granite Surround Finish (Black Granite Interior)	64
D. Mantel and Wall Projections	73

11 Appliance Setup

A. Remove the Shipping Materials	74
B. Clean the Appliance	74
C. Install Burner Glass	74
D. Install Modern Log Set	74
E. Install Media	74
F. Barrier Glass	74
G. Firebox Glass Assembly	76

12 Reference Materials

A. Vent Components Diagrams	77 ←
B. Accessories	86

→ = Contains updated information.

→ Installation Standard Work Checklist

ATTENTION INSTALLER:
Follow this Standard Work Checklist

This standard work checklist is to be used by the installer in conjunction with, not instead of, the instructions contained in this installation manual.

Customer: _____	Date Installed: _____
Lot/Address: _____	Location of Fireplace: _____
Model (circle one): PRIMO48 PRIMO60 PRIMO72	Installer: _____
PRIMO48ST PRIMO60ST PRIMO72ST	Dealer/Distributor Phone # _____
	Serial #: _____

 **WARNING! Risk of Fire or Explosion!** Failure to install appliance according to these instructions can lead to a fire or explosion.

Appliance Install Sections 3 , 6 and 11

Verified that the chase is insulated and sealed. (Pg. 16)	<input type="checkbox"/>	IF NO, WHY? _____
Verified clearances to combustibles. (Pg. 12)	<input type="checkbox"/>	_____
Fireplace is leveled and secured. (Pg. 26)	<input type="checkbox"/>	_____
Barrier glass installed correctly. "THIS SIDE OUT" is readable. (Section 11)	<input type="checkbox"/>	_____

Venting/Chimney/PowerFlow™ Heat Management Sections 4,5 and 7

Venting configuration complies to vent diagrams. (Section 4)	<input type="checkbox"/>	_____
Venting installed, locked, secured in place and sealed with correct clearance.	<input type="checkbox"/>	_____
Firestops installed. (Section 5)	<input type="checkbox"/>	_____
Attic insulation shield installed. (Section 5)	<input type="checkbox"/>	_____
Exterior wall/Roof flashing installed and sealed. (Section 7)	<input type="checkbox"/>	_____
Terminations installed and sealed. (Section 7)	<input type="checkbox"/>	_____
PVI-SLP or PVLP-SLP power vent installed with correct baffle setting.	<input type="checkbox"/>	_____
HEAT-ZONE-PRIMO and/or HEAT-OUT-PRIMO installed and vented properly; complies with vent run min./max. requirements in installation manual.	<input type="checkbox"/>	_____

Electrical Section 8 (Pg 44-48)

Unswitched power (110-120 VAC) provided to the appliance.	<input type="checkbox"/>	_____
LED switch wires properly installed.	<input type="checkbox"/>	_____
If only HEAT-OUT-PRIMO is installed: Wall switch plate and toggle switch not installed.	<input type="checkbox"/>	_____

Gas Section 9 (Pg 49-53)

Proper appliance for fuel type.	<input type="checkbox"/>	_____
Was a conversion performed?	<input type="checkbox"/>	_____
Leak check performed and inlet pressure verified.	<input type="checkbox"/>	_____
Verified proper air shutter setting for installation type.	<input type="checkbox"/>	_____
Verify that the gas access plate remains installed. (Pg 52)	<input type="checkbox"/>	_____

Finishing Section 10 (Pg 54-73)

1/2 inch sheetrock used as recommended.	<input type="checkbox"/>	_____
Verified all clearances meet installation manual requirements.	<input type="checkbox"/>	_____
Mantels and wall projections comply with installation manual requirements.	<input type="checkbox"/>	_____
Granite or Clean Face finishing complete and complies with clearance requirements in installation manual.	<input type="checkbox"/>	_____
Barrier glass properly installed.	<input type="checkbox"/>	_____

Appliance Setup Section 11 (Pg 74-76)

All packaging and protective materials removed (inside & outside of appliance).	<input type="checkbox"/>	_____
Glass or granite panels and media installed correctly.	<input type="checkbox"/>	_____
Firebox glass assembly installed and secured.	<input type="checkbox"/>	_____
Accessories installed properly.	<input type="checkbox"/>	_____
Manual bag and all of its contents are removed from inside/under the appliance and given to party responsible for use and operation.	<input type="checkbox"/>	_____
Started appliance and verified no gas leaks exist.	<input type="checkbox"/>	_____
Multicolored LED lights work in all switched positions.	<input type="checkbox"/>	_____

Hearth & Home Technologies recommends the following:

- Photographing the installation and copying this checklist for your file.
- That this checklist remain visible at all times on the appliance until the installation is complete.

Comments: Further description of the issues, who is responsible (Installer/ Builder/ Other Trades, etc) and corrective action needed _____

Comments Communicated to party responsible _____ by _____ on _____
(Builder / Gen. Contractor/) (Installer) (Date)

→ = Contains updated information.

1 Product Specific and Important Safety Information

A. Appliance Certification

<p>MODEL: PRIMO48, PRIMO48ST PRIMO60, PRIMO60ST, PRIMO72, PRIMO72ST LABORATORY: Underwriters Laboratories, Inc. (UL) TYPE: Direct Vent Gas Appliance STANDARD: ANSI Z21.50-2014/CSA 2.22-2014</p>

This product is listed to ANSI standards for “Vented Gas Fireplaces” and applicable sections of “Gas Burning Heating Appliances for Manufactured Homes and Recreational Vehicles”, and “Gas Fired Appliances for Use at High Altitudes”.

NOTICE: This installation must conform with local codes. In the absence of local codes you must comply with the National Fuel Gas Code, ANSI Z223.1-latest edition in the U.S.A. and the CAN/CGA B149 Installation Codes in Canada.

<p>NOT INTENDED FOR USE AS A PRIMARY HEAT SOURCE. This appliance is tested and approved as either supplemental room heat or as a decorative appliance. It should not be factored as primary heat in residential heating calculations.</p>
--

B. Glass Specifications

The firebox glass and the barrier glass on this appliance are tempered glass. Hearth & Home Technologies appliances manufactured with tempered glass may be installed in hazardous locations such as bathtub enclosures as defined by the Consumer Product Safety Commission (CPSC). The tempered glass has been tested and certified to the requirements of **ANSI Z97.1** and **CPSC 16 CFR 1202** (Safety Glazing Certification Council **SGCC# 1595** and **1597**. Architectural Testing, Inc. Reports **02-31919.01** and **02-31917.01**).

This statement is in compliance with **CPSC 16 CFR Section 1201.5** “Certification and labeling requirements” which refers to **15 U.S. Code (USC) 2063** stating “...Such certificate shall accompany the product or shall otherwise be furnished to any distributor or retailer to whom the product is delivered.”

Some local building codes require the use of tempered glass with permanent marking in such locations. Glass meeting this requirement is available from the factory. Please contact your dealer or distributor to order.

C. BTU Specifications

Models (U.S. or Canada)		Maximum Input BTU/h	Minimum Input BTU/h	Orifice Size (DMS)
PRIMO48 (NG)	(0-2000 FT)	45,000	31,000	#30
PRIMO48 (Propane)	(0-2000 FT)	45,000	33,000	#47
PRIMO48ST (NG)	(0-2000 FT)	45,000	31,000	#30
PRIMO48ST (Propane)	(0-2000 FT)	45,000	33,000	#47
PRIMO60 (NG)	(0-2000 FT)	55,000	38,000	#26
PRIMO60 (Propane)	(0-2000 FT)	50,000	35,000	#45
PRIMO60ST (NG)	(0-2000 FT)	55,000	38,000	#26
PRIMO60ST (Propane)	(0-2000 FT)	50,000	35,000	#45
PRIMO72 (NG)	(0-2000 FT)	61,000	41,000	#23
PRIMO72ST (NG)	(0-2000 FT)	61,000	41,000	#23

D. High Altitude Installations

NOTICE: If the heating value of the gas has been reduced, these rules do not apply. Check with your local gas utility or authorities having jurisdiction.

When installing above 2000 feet elevation:

- In the USA: Reduce input rate 4% for each 1000 feet above 2000 feet.
- In CANADA: Input ratings are certified without a reduction of input rate for elevations up to 4500 feet (1370 m) above sea level. Please consult provincial and/or local authorities having jurisdiction for installations at elevations above 4500 feet (1370 m).

Check with your local gas utility to determine proper orifice size.

E. Non-Combustible Materials Specification

Material which will not ignite and burn. Such materials are those consisting entirely of steel, iron, brick, tile, concrete, slate, glass or plasters, or any combination thereof.

Materials that are reported as passing **ASTM E 136, Standard Test Method for Behavior of Materials in a Vertical Tube Furnace at 750 °C** shall be considered non-combustible materials.

F. Combustible Materials Specification

Materials made of or surfaced with wood, compressed paper, plant fibers, plastics, or other material that can ignite and burn, whether flame proofed or not, or plastered or unplastered shall be considered combustible materials.

G. Electrical Codes

NOTICE: *This appliance must be electrically wired and grounded in accordance with local codes or, in the absence of local codes, with **National Electric Code ANSI/NFPA 70-latest edition or the Canadian Electric Code CSA C22.1.***

- A 110-120 VAC circuit for this product must be protected with ground-fault circuit-interrupter protection, in compliance with the applicable electrical codes, when it is installed in locations such as in bathrooms or near sinks.

Note: The following requirements reference various Massachusetts and national codes not contained in this document.

H. Requirements for the Commonwealth of Massachusetts

For all side wall horizontally vented gas fueled equipment installed in every dwelling, building or structure used in whole or in part for residential purposes, including those owned or operated by the Commonwealth and where the side wall exhaust vent termination is less than seven (7) feet above finished grade in the area of the venting, including but not limited to decks and porches, the following requirements shall be satisfied:

Installation of Carbon Monoxide Detectors

At the time of installation of the side wall horizontal vented gas fueled equipment, the installing plumber or gas fitter shall observe that a hard wired carbon monoxide detector with an alarm and battery back-up is installed on the floor level where the gas equipment is to be installed. In addition, the installing plumber or gas fitter shall observe that a battery operated or hard wired carbon monoxide detector with an alarm is installed on each additional level of the dwelling, building or structure served by the side wall horizontal vented gas fueled equipment. It shall be the responsibility of the property owner to secure the services of qualified licensed professionals for the installation of hard wired carbon monoxide detectors.

In the event that the side wall horizontally vented gas fueled equipment is installed in a crawl space or an attic, the hard wired carbon monoxide detector with alarm and battery back-up may be installed on the next adjacent floor level.

In the event that the requirements of this subdivision can not be met at the time of completion of installation, the owner shall have a period of thirty (30) days to comply with the above requirements; provided, however, that during said thirty (30) day period, a battery operated carbon monoxide detector with an alarm shall be installed.

Approved Carbon Monoxide Detectors

Each carbon monoxide detector as required in accordance with the above provisions shall comply with NFPA 720 and be ANSI/UL 2034 listed and IAS certified.

Signage

A metal or plastic identification plate shall be permanently mounted to the exterior of the building at a minimum height of eight (8) feet above grade directly in line with the exhaust vent terminal for the horizontally vented gas fueled heating appliance or equipment. The sign shall read, in print size no less than one-half (1/2) in. in size, “**GAS VENT DIRECTLY BELOW. KEEP CLEAR OF ALL OBSTRUCTIONS**”.

Inspection

The state or local gas inspector of the side wall horizontally vented gas fueled equipment shall not approve the installation unless, upon inspection, the inspector observes carbon monoxide detectors and signage installed in accordance with the provisions of 248 CMR 5.08(2)(a)1 through 4.

Exemptions

The following equipment is exempt from 248 CMR 5.08(2)(a)1 through 4:

- The equipment listed in Chapter 10 entitled “Equipment Not Required To Be Vented” in the most current edition of NFPA 54 as adopted by the Board; and
- Product Approved side wall horizontally vented gas fueled equipment installed in a room or structure separate from the dwelling, building or structure used in whole or in part for residential purposes.

MANUFACTURER REQUIREMENTS

Gas Equipment Venting System Provided

When the manufacturer of Product Approved side wall horizontally vented gas equipment provides a venting system design or venting system components with the equipment, the instructions provided by the manufacturer for installation of the equipment and the venting system shall include:

- Detailed instructions for the installation of the venting system design or the venting system components; and
- A complete parts list for the venting system design or venting system.

Gas Equipment Venting System NOT Provided

When the manufacturer of a Product Approved side wall horizontally vented gas fueled equipment does not provide the parts for venting the flue gases, but identifies “special venting systems”, the following requirements shall be satisfied by the manufacturer:

- The referenced “special venting system” instructions shall be included with the appliance or equipment installation instructions; and
- The “special venting systems” shall be Product Approved by the Board, and the instructions for that system shall include a parts list and detailed installation instructions.

A copy of all installation instructions for all Product Approved side wall horizontally vented gas fueled equipment, all venting instructions, all parts lists for venting instructions, and/or all venting design instructions shall remain with the appliance or equipment at the completion of the installation.

See Gas Connection section for additional Commonwealth of Massachusetts requirements.

2 Getting Started

A. Design and Installation Considerations

Heat & Glo direct vent gas appliances are designed to operate with all combustion air siphoned from outside of the building and all exhaust gases expelled to the outside. No additional outside air source is required.

Installation MUST comply with local, regional, state and national codes and regulations. Consult insurance carrier, local building inspector, fire officials or authorities having jurisdiction over restrictions, installation inspection and permits.

Before installing, determine the following:

- Where the appliance is to be installed.
- The vent system configuration to be used.
- Gas supply piping.
- Configuration of the required PowerFlow™ Heat Management System: HEAT-ZONE-PRIMO and/or HEAT-OUT-PRIMO.

WARNING! Risk of Fire! Either the HEAT-ZONE-PRIMO or the HEAT-OUT-PRIMO PowerFlow™ Heat Management System must remain ON during operation of the appliance. Overheating will occur. Appliance will shut down.

- Electrical wiring requirements.
- Framing and finishing details.
- Which required power vent system will be used: PVI-SLP or PVLP-SLP.

WARNING! Risk of Fire! PRIMO models must be power vented using PVI-SLP or PVLP-SLP and have a PowerFlow™ Heat Management System installed. Failure to vent properly could cause overheating and fire.



Installation and service of this appliance should be performed by qualified personnel. Hearth & Home Technologies suggests NFI certified or factory trained professionals, or technicians supervised by an NFI certified professional (www.nficertified.org).

Improper installation, adjustment, alteration, service or maintenance can cause injury or property damage. For assistance or additional information, consult a qualified service technician, service agency or your dealer.

B. Tools and Supplies Needed

Before beginning the installation be sure that the following tools and building supplies are available.

- | | |
|--------------|--|
| Tape measure | Framing material |
| Pliers | Non-corrosive leak check solution |
| Hammer | Phillips screwdriver |
| Gloves | Framing square |
| Voltmeter | Electric drill and bits (1/4 in. magnetic) |
| Plumb line | Safety glasses |
| Level | Reciprocating saw |
| Manometer | Flat blade screwdriver |
- Suction Cups to lift glass (See Section 11)
Clamps for Granite Finish (See Section 10)
1/2 - 3/4 in. length, #6 or #8 Self-drilling screws
Caulking material (300°F minimum continuous exposure rating)

C. Inspect Appliance and Components

- Carefully remove the appliance and components from the packaging.
- The vent system components and decorative finishes are shipped in separate packages.
- Report to your dealer any parts damaged in shipment, particularly the condition of the glass.
- **Read all of the instructions before starting the installation. Follow these instructions carefully during the installation to ensure maximum safety and benefit.**

WARNING! Risk of Fire or Explosion! Damaged parts could impair safe operation. **DO NOT** install damaged, incomplete or substitute components. Keep appliance dry.

Hearth & Home Technologies disclaims any responsibility for, and the warranty will be voided by, the following actions:

- Installation and use of any damaged appliance or vent system component.
- Modification of the appliance or vent system.
- Modification of the approved power vent system: (PVI-SLP or PVLP-SLP)
- Installation other than as instructed by Hearth & Home Technologies.
- Improper positioning of the media or the finishing.
- Installation and/or use of any component part not approved by Hearth & Home Technologies.

Any such action may cause a fire hazard.

WARNING! Risk of Fire, Explosion or Electric Shock! **DO NOT** use this appliance if any part has been under water. Call a qualified service technician to inspect the appliance and to replace any part of the control system and/or gas control which has been under water.

3 Framing and Clearances

A. Appliance/Decorative Finish Dimension Diagrams

Dimensions are actual appliance dimensions. Use for reference only. For framing dimensions and clearances refer to Section 3.B.

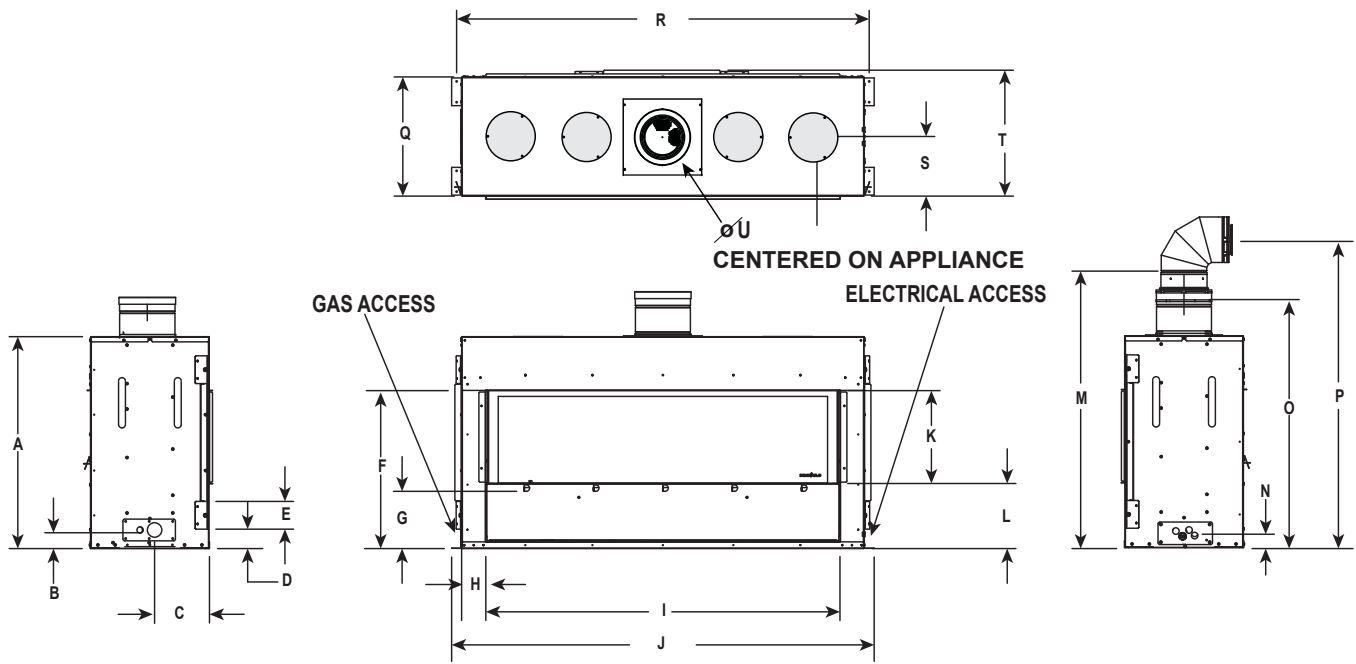

Location	PRIMO48		PRIMO60		PRIMO72	
	Inches	Millimeters	Inches	Millimeters	Inches	Millimeters
A	30-9/16	776	30-9/16	776	30-9/16	776
B	2-5/16	59	2-5/16	59	2-5/16	59
C	7-11/16	195	7-11/16	195	7-11/16	195
D	2-13/16	71	2-13/16	71	2-13/16	71
E	4	102	4	102	4	102
F	23-13/16	605	23-13/16	605	23-13/16	605
G	8-1/4	210	8-1/4	210	8-1/4	210
H	3-1/2	89	3-7/16	87	3-7/16	87
I	51-1/16	1297	63-1/16	1602	75-1/16	1907
J	60-15/16	1547	72-15/16	1853	84-15/16	2157
K	13-3/8	340	13-3/8	340	13-3/8	340
L	9-3/8	238	9-3/8	238	9-3/8	238
M	39-1/2	1003	39-1/2	1003	39-1/2	1003
N	2-1/16	52	2-1/16	52	2-1/16	52
O	37	940	37	940	37	940
P*	44-3/4	1137	44-3/4	1137	44-3/4	1137
Q	17-3/16	437	17-3/16	437	17-3/16	437
R	59-1/2	1511	71-1/2	1816	83-1/2	2121
S	8-5/8	219	8-5/8	219	8-5/8	219
T	18-3/16	462	18-1/8	460	18-1/8	460
U	8	203	8	203	8	203

* = Minimum Vent Height (using SLP90)

Figure 3.1 Appliance Dimensions - PRIMO48, PRIMO60, PRIMO72

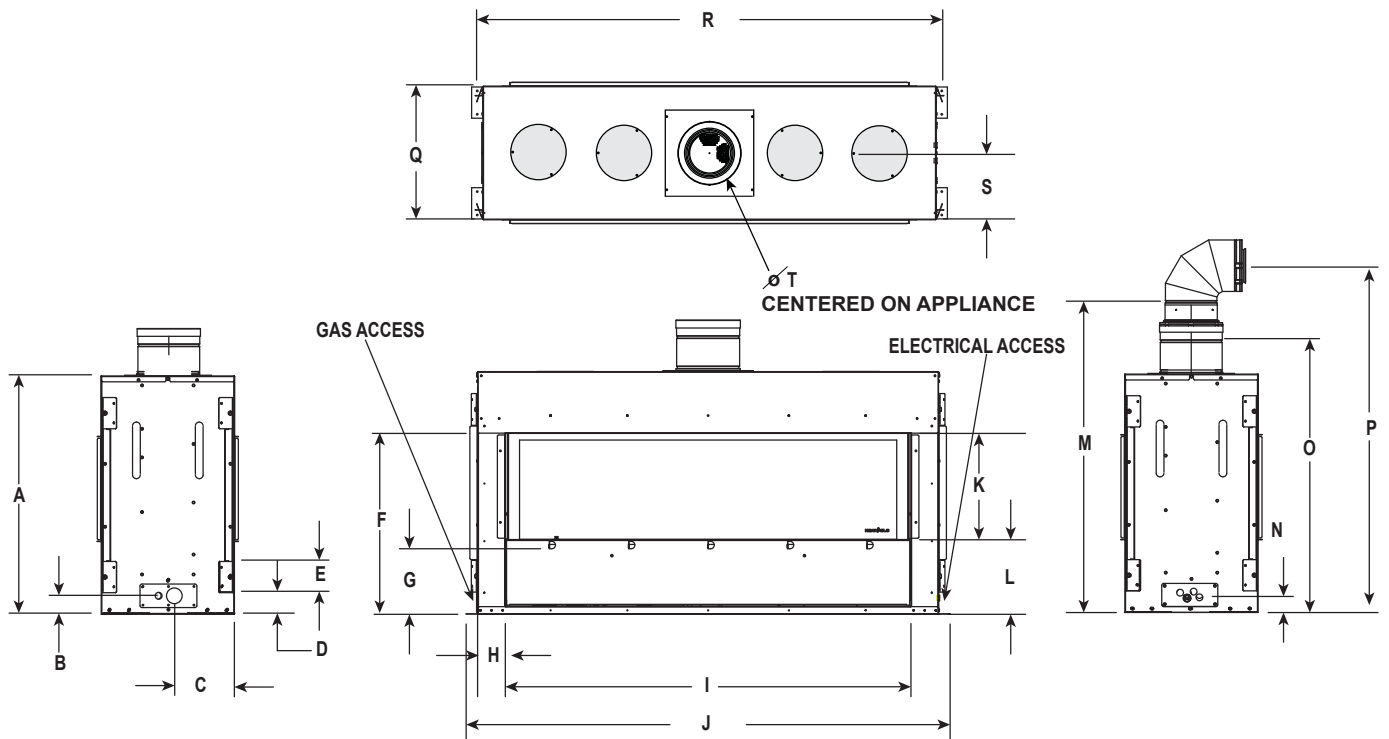

Location	PRIMO48ST		PRIMO60ST		PRIMO72ST	
	Inches	Millimeters	Inches	Millimeters	Inches	Millimeters
A	30-9/16	776	30-9/16	776	30-9/16	776
B	2-5/16	59	2-5/16	59	2-5/16	59
C	7-11/16	195	7-11/16	195	7-11/16	195
D	2-13/16	71	2-13/16	71	2-13/16	71
E	4	102	4	102	4	102
F	23-13/16	605	23-13/16	605	23-13/16	605
G	8-1/4	210	8-1/4	210	8-1/4	210
H	3-1/2	89	3-7/16	87	3-7/16	87
I	51-1/16	1297	63-1/16	1602	75-1/16	1907
J	60-15/16	1547	72-15/16	1853	84-15/16	2157
K	13-3/8	340	13-3/8	340	13-3/8	340
L	9-3/8	238	9-3/8	238	9-3/8	238
M	39-1/2	1003	39-1/2	1003	39-1/2	1003
N	2-1/16	52	2-1/16	52	2-1/16	52
O	37	940	37	940	37	940
P*	44-3/4	1137	44-3/4	1137	44-3/4	1137
Q	17-3/16	437	17-3/16	437	17-3/16	437
R	59-1/2	1511	71-1/2	1816	83-1/2	2121
S	8-5/8	219	8-5/8	219	8-5/8	219
T	8	203	8	203	8	203

* = Minimum Vent Height (using SLP90)

Figure 3.2 Appliance Dimensions - PRIMO48ST, PRIMO60ST, PRIMO72ST

CLEAN FACE FINISH (BLACK GLASS INTERIOR)

PRIMO48-CF PRIMO48ST-CF
 PRIMO60-CF PRIMO60ST-CF
 PRIMO72-CF PRIMO72ST-CF

Note: See Section 10 for mantel and finishing requirements and additional clean face finishing details.

NOTE: Sheetrock (1/2 inch) may be installed up to appliance opening.

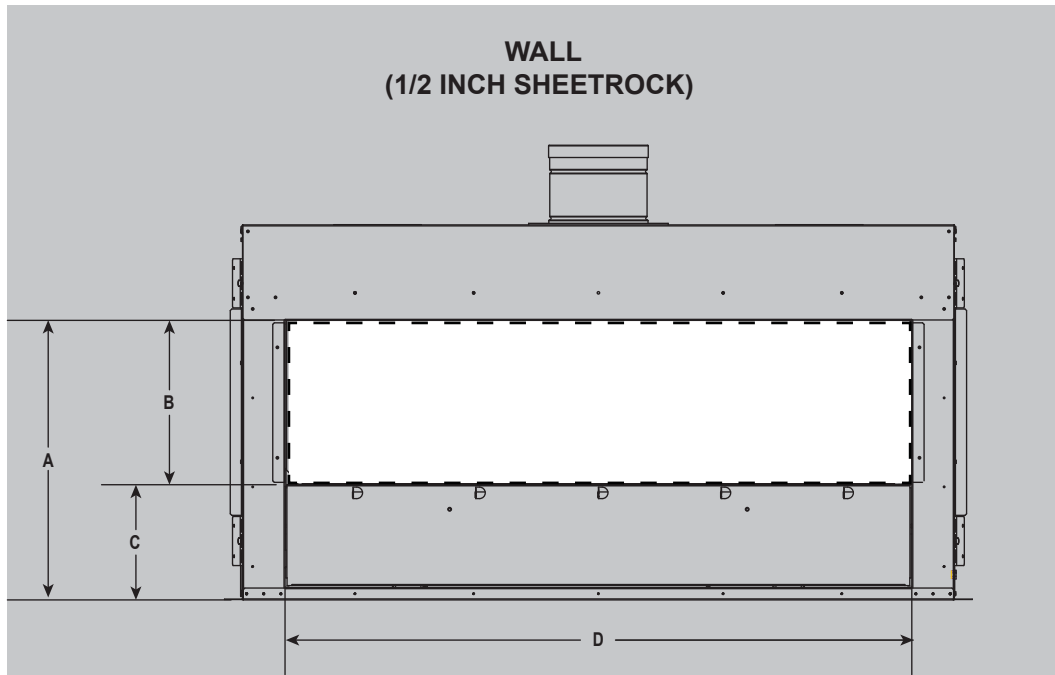

Location	PRIMO48 PRIMO48ST		PRIMO60 PRIMO60ST		PRIMO72 PRIMO72ST	
	Inches	Millimeters	Inches	Millimeters	Inches	Millimeters
A	22-3/4	579	22-3/4	579	22-3/4	579
B	13-3/8	340	13-3/8	340	13-3/8	340
C	9-3/8	238	9-3/8	238	9-3/8	238
D	51	1295	63	1600	75	1905

Figure 3.3 Clean Face Finish Dimensions

BLACK GRANITE SURROUND FINISH (BLACK GRANITE INTERIOR)

PRIMO48-GR PRIMO48ST-GR
 PRIMO60-GR PRIMO60ST-GR
 PRIMO72-GR PRIMO72ST-GR

Note: See Section 10 for mantel and finishing requirements and additional clean face finishing details.

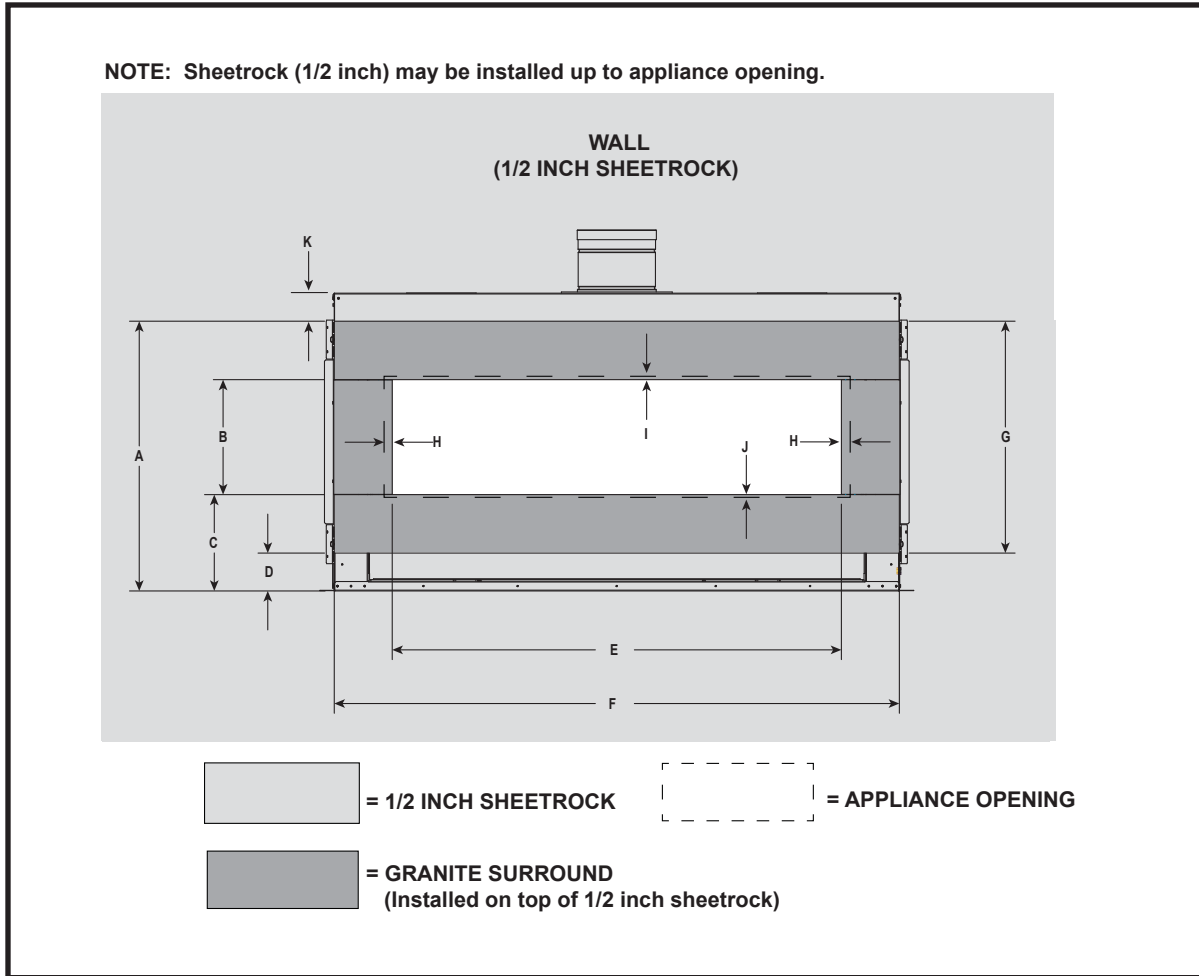

Location	PRIMO48/PRIMO48ST		PRIMO60/PRIMO60ST		PRIMO72/PRIMO72ST	
	Inches	Millimeters	Inches	Millimeters	Inches	Millimeters
A	27-11/16	703	27-11/16	703	27-11/16	703
B	11-13/16	300	11-13/16	300	11-13/16	300
C	9-7/8	251	9-7/8	251	9-7/8	251
D	3-7/8	98	3-7/8	98	3-7/8	98
E	46-1/16	1170	58-1/16	1475	70-1/16	1780
F	58	1473	70	1778	82	2083
G	23-13/16	605	23-13/16	605	23-13/16	605
H	2-1/2	64	2-1/2	64	2-1/2	64
I	1-1/4	32	1-1/4	32	1-1/4	32
J	1/2	13	1/2	13	1/2	13
K	3-3/4	82	3-3/4	82	3-3/4	82

Figure 3.4 Black Granite Surround Finish Dimensions

B. Clearances to Combustibles

When selecting a location for the appliance it is important to consider the required clearances to walls. See Figure 3.5 and Figure 3.7.

WARNING! Risk of Fire or Burns! Provide adequate clearance around air openings and for service access. Due to high temperatures, the appliance should be located out of traffic and away from furniture and draperies.

NOTICE: Illustrations reflect typical installations and are FOR DESIGN PURPOSES ONLY. Illustrations/diagrams are not drawn to scale. Actual installation could vary due to individual design preference.

It is important to follow the framing and finishing instructions step by step to ensure proper placement of fireplace in the surrounding framing/finishing materials.

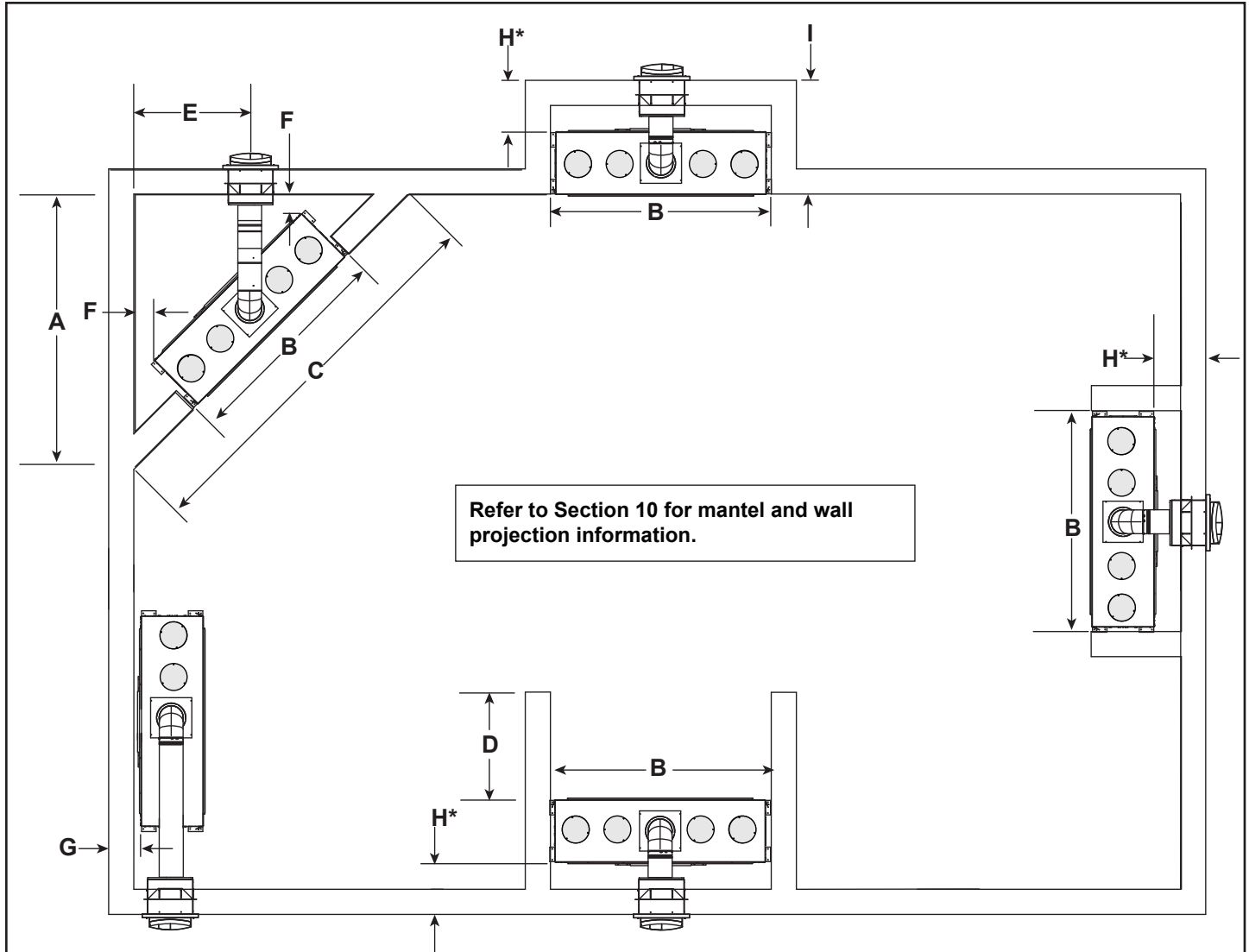

Model		A	B	C	D (MAX.)	E	F	G Min.	H*	I
PRIMO48	Inches	70-3/4	60-1/4	100-3/8	36	28-1/2	1	1	See H* note in Figure 3.6.	29-3/4
	Millimeters	1797	1530	2550	914	724	25	25		756
PRIMO60	Inches	79-1/2	72-1/4	112-3/8	36	31-3/4	1	1		29-3/4
	Millimeters	2019	1835	2854	914	806	25	25		756
PRIMO72	Inches	88	84-1/4	124-3/8	36	35-1/4	1	1		29-3/4
	Millimeters	2235	2139	3159	914	895	25	25		756

Figure 3.5 Appliance Locations PRIMO48, PRIMO60, PRIMO72

PVLP-SLP Minimum Horizontal Footprint

This diagram shows the scenario if the 12-1/2 inch measurement was not accommodated for prior to installation. The PVLP-BEK may be installed in the 5 inch gap or a small bump out may be created on the exterior wall to accommodate for the additional space needed.

H*=12-1/2 inches if using PVLP-SLP plus one SLP elbow. This is the minimum vent configuration and is composed of the factory-installed 6 inch DVP component, DVP-2SLP converter, SLP90 elbow and PVLP-SLP termination cap.

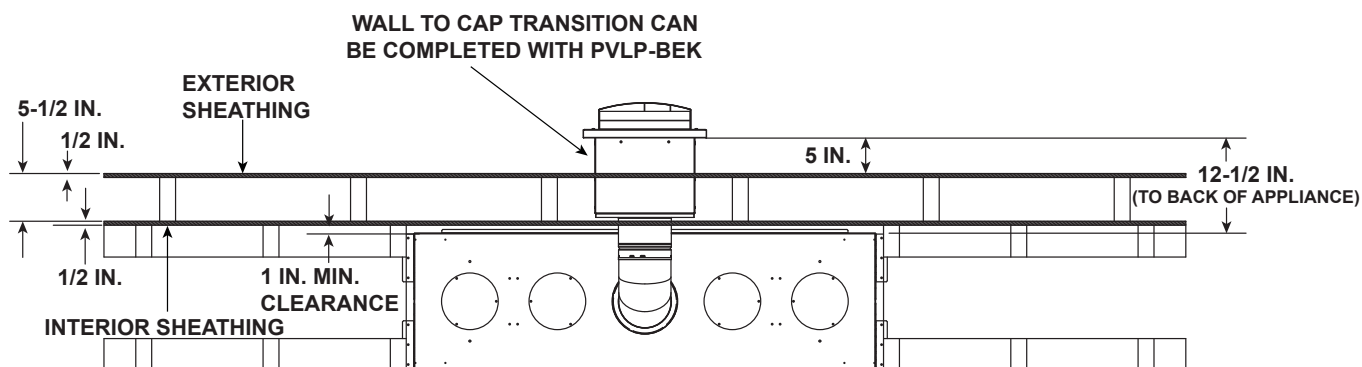

The dimensions above assume:

- 2 in. X 6 in. exterior wall studs
- 1/2 in. thick interior and exterior wall sheathing material

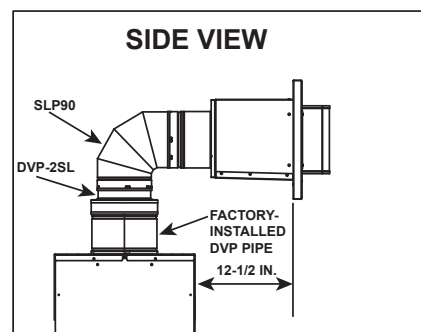
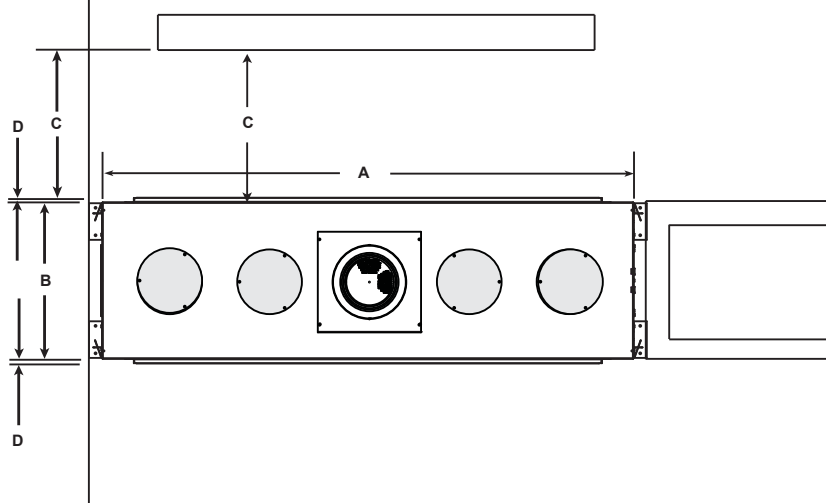

Figure 3.6 PVLP-SLP Minimum Horizontal Footprint (PRIMO48, PRIMO60, PRIMO72)



NOTICE: This See-Through appliance is NOT designed or approved for an indoor/outdoor application.

Model		A	B	C	D
PRIMO48ST	Inches	60-1/4	17-1/8	48	1/2
	Millimeters	1530	435	1219	13
PRIMO60ST	Inches	72-1/4	17-1/8	48	1/2
	Millimeters	1835	435	1219	13
PRIMO72ST	Inches	84-1/4	17-1/8	48	1/2
	Millimeters	2140	435	1219	13

Figure 3.7 Appliance Locations PRIMO48ST, PRIMO60ST, PRIMO72ST

PRIMO48, PRIMO60, PRIMO72

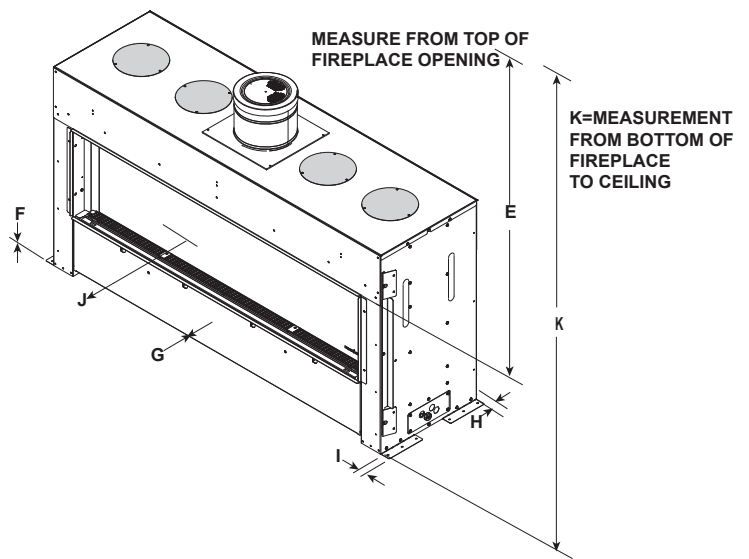
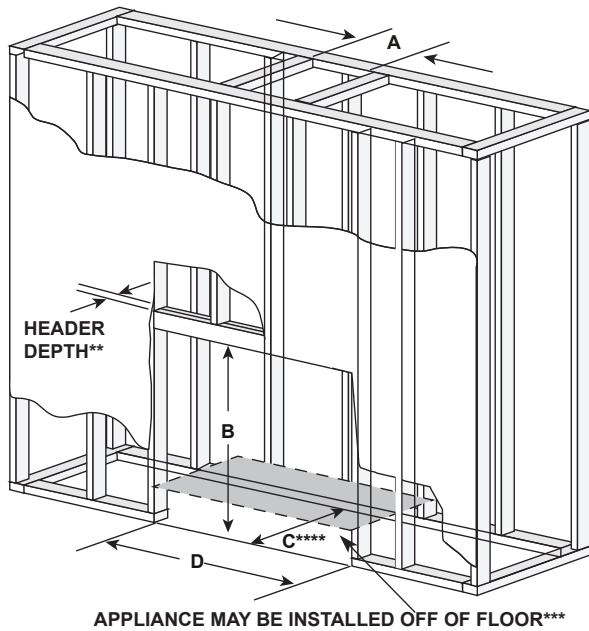

MINIMUM FRAMING DIMENSIONS* (Single-sided Models)

	A		B	C****	D	E	F	G	H	I	J	K
	Rough Opening (DVP Vent Pipe)	Rough Opening (SLP Vent Pipe)	Rough Opening (Height)	Rough Opening (Depth)	Rough Opening (Width)	Clearance to Ceiling	Combustible Floor	Combustible Flooring	Behind Appliance	Sides of Appliance	Front of Appliance	Clearance to Ceiling
PRIMO48												
Inches	10	9	42	18-1/4	60-1/4	31	0	0	1	1	36	53-3/4
Millimeters	254	229	1067	464	1530	787	0	0	25	25	914	1365
PRIMO60												
Inches	10	9	48	18-1/4	72-1/4	31	0	0	1	1	36	53-3/4
Millimeters	254	229	1219	464	1835	787	0	0	25	25	914	1365
PRIMO72												
Inches	10	9	48	18-1/4	84-1/4	31	0	0	1	1	36	53-3/4
Millimeters	254	229	1219	464	2140	787	0	0	25	25	914	1365

** = Header depth not to exceed 3-1/2 inches.

*** = If appliance is installed off of floor, maintain required clearances to combustibles.
Construct platform in accordance with local building codes.

**** = 1.) See Figure 3.6 for PVLPSLP minimum horizontal footprint.

The rough opening depth will change if installing PVLPSLP with minimum vent configuration.

= 2.) Adjust framing dimensions for interior sheathing (such as sheetrock).

Figure 3.8 Clearances to Combustibles-PRIMO48, PRIMO60, PRIMO72

PRIMO48ST, PRIMO60ST, PRIMO72ST

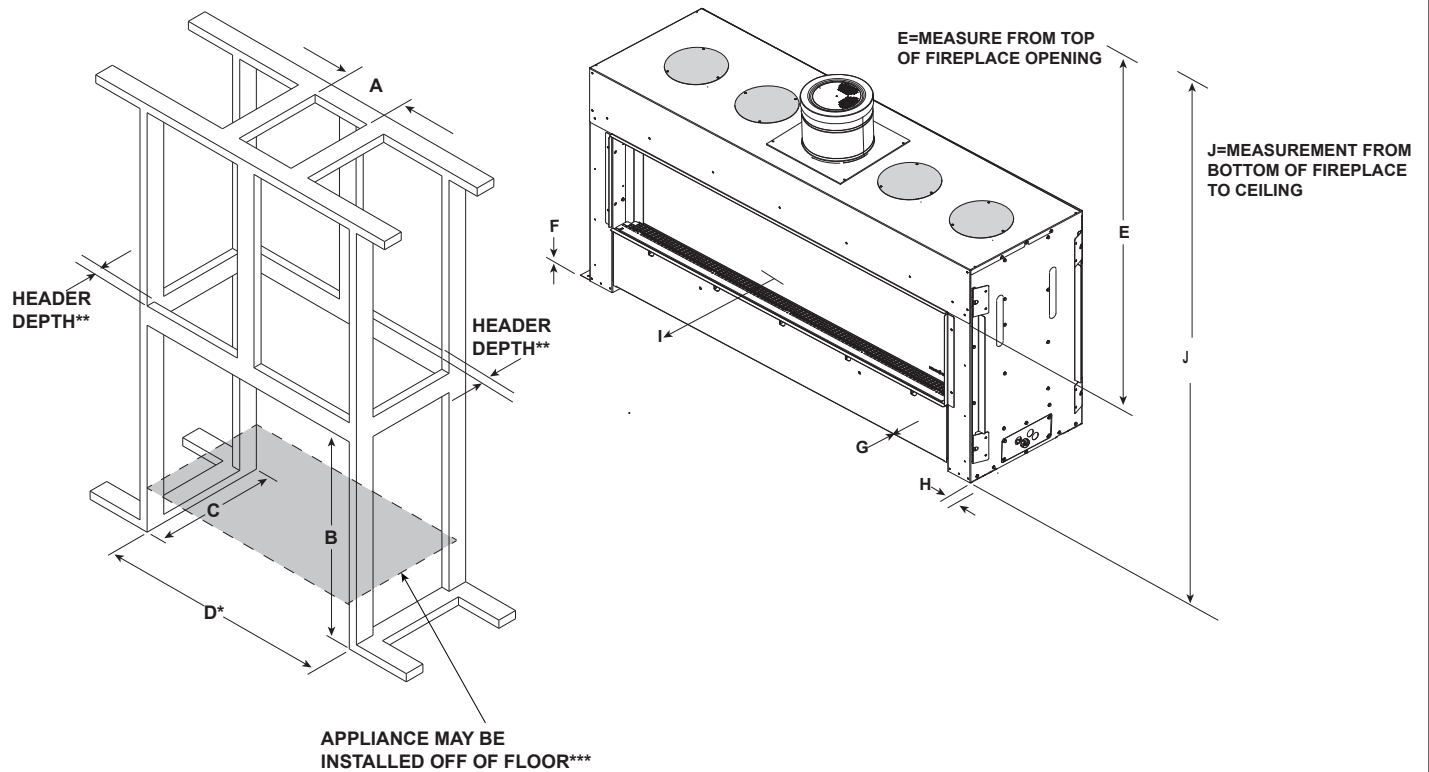

MINIMUM FRAMING DIMENSIONS* (See-Through Models)

	A		B	C	D*	E	F	G	H	I	J	
PRIMO48ST	Rough Opening (DVP Vent Pipe)	Rough Opening (SLP Vent Pipe)	Rough Opening (Height)	Rough Opening (Depth)	Rough Opening (Width)	Clearance to Ceiling	Combustible Floor	Combustible Flooring	Sides of Appliance	Front or Rear of Appliance	Clearance to Ceiling	
	Inches	10	9	42	17	60-1/4	31	0	0	1	36	53-3/4
	Millimeters	254	229	1067	432	1530	787	0	0	25	914	1365
PRIMO60ST	A		B	C	D*	E	F	G	H	I	J	
	Rough Opening (DVP Vent Pipe)	Rough Opening (SLP Vent Pipe)	Rough Opening (Height)	Rough Opening (Depth)	Rough Opening (Width)	Clearance to Ceiling	Combustible Floor	Combustible Flooring	Sides of Appliance	Front or Rear of Appliance	Clearance to Ceiling	
	Inches	10	9	48	17	72-1/4	31	0	0	1	36	53-3/4
Millimeters	254	229	1219	432	1835	787	0	0	25	914	1365	
PRIMO72ST	A		B	C	D*	E	F	G	H	I	J	
	Rough Opening (DVP Vent Pipe)	Rough Opening (SLP Vent Pipe)	Rough Opening (Height)	Rough Opening (Depth)	Rough Opening (Width)	Clearance to Ceiling	Combustible Floor	Combustible Flooring	Sides of Appliance	Front or Rear of Appliance	Clearance to Ceiling	
	Inches	10	9	48	17	84-1/4	31	0	0	1	36	53-3/4
Millimeters	254	229	1219	432	2140	787	0	0	25	914	1365	

* = Adjust framing dimensions for interior sheathing (such as 1/2 inch sheetrock)

**= Header depth not to exceed 3-1/2 inches.

***= If appliance is installed off of floor, maintain required clearances to combustibles.

Construct platform in accordance with local building codes.

Figure 3.9 Clearances to Combustibles-PRIMO48ST, PRIMO60ST, PRIMO72ST

C. Constructing the Appliance Chase

A chase is a vertical box-like structure built to enclose the gas appliance and/or its vent system. In cooler climates the vent should be enclosed inside the chase.

NOTICE: *Treatment of ceiling firestops and wall shield firestops and construction of the chase may vary with the type of building. These instructions are not substitutes for the requirements of local building codes. Therefore, you MUST check local building codes to determine the requirements to these steps.*

Chases should be constructed in the manner of all outside walls of the home to prevent cold air drafting problems. The chase should not break the outside building envelope in any manner.

Walls, ceiling, base plate and cantilever floor of the chase should be insulated. Vapor and air infiltration barriers should be installed in the chase as per regional codes for the rest of the home. Additionally, in regions where cold air infiltration may be an issue, the inside surfaces may be sheetrocked and taped (or an equivalent method may be used) to achieve maximum air tightness.

To further prevent drafts, the wall shield and ceiling firestops should be caulked with caulk with a minimum of 300°F continuous exposure rating to seal gaps. Gas line holes and other openings should be caulked with caulk with a minimum of 300°F continuous exposure rating or stuffed with unfaced insulation. If the appliance is being installed on a cement surface, a layer of plywood may be placed underneath to prevent conducting cold up into the room.

Note: Figure 3.8 and Figure 3.9 show the fireplace installed on the floor. However, this fireplace can be elevated off the floor provided that the fireplace is properly supported by framing materials and the ceiling clearances are maintained.

D. Floor Protection

NOTICE: *Install appliance on hard metal or wood surfaces extending full width and depth. DO NOT install directly on carpeting, vinyl, tile or any combustible material other than wood.*

WARNING! Risk of Fire! *Maintain specified air space clearances to appliance and vent pipe:*

- Insulation and other materials must be secured to prevent accidental contact.
- The chase must be properly blocked to prevent blown insulation or other combustibles from entering and making contact with fireplace or chimney.
- Failure to maintain airspace could cause overheating and fire.

4 Termination Location and Vent Information

A. Vent Termination Minimum Clearances PVI-SLP

⚠ WARNING

Fire Risk.
Maintain vent clearance to combustibles as specified.

- **DO NOT** pack air space with insulation or other materials.

Failure to keep insulation or other materials away from vent pipe could cause overheating and fire.

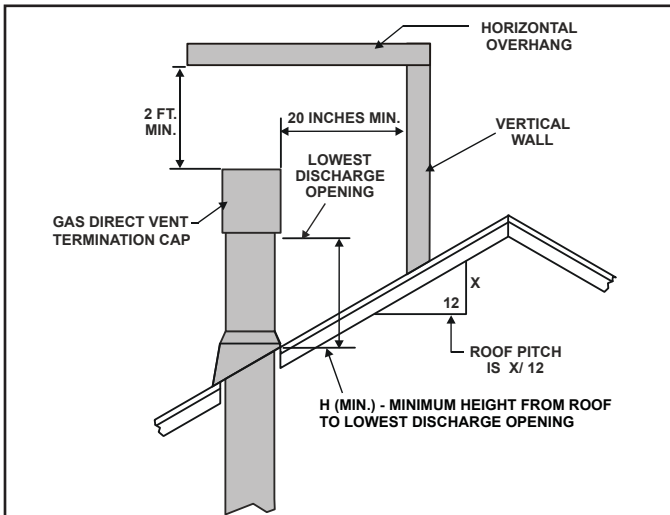

Roof Pitch	H (Min.) Ft.
Flat to 6/12.....	1.0*
Over 6/12 to 7/12.....	1.25*
Over 7/12 to 8/12.....	1.5*
Over 8/12 to 9/12.....	2.0*
Over 9/12 to 10/12.....	2.5*
Over 10/12 to 11/12.....	3.25
Over 11/12 to 12/12.....	4.0
Over 12/12 to 14/12.....	5.0
Over 14/12 to 16/12.....	6.0
Over 16/12 to 18/12.....	7.0
Over 18/12 to 20/12.....	7.5
Over 20/12 to 21/12.....	8.0

* 3 foot minimum in snow regions

Figure 4.1 Minimum Height From Roof To Lowest Discharge Opening

A	B
6 in. (minimum) up to 20 in. 152 mm/508 mm	18 in. minimum 457 mm
20 in. and over	0 in. minimum

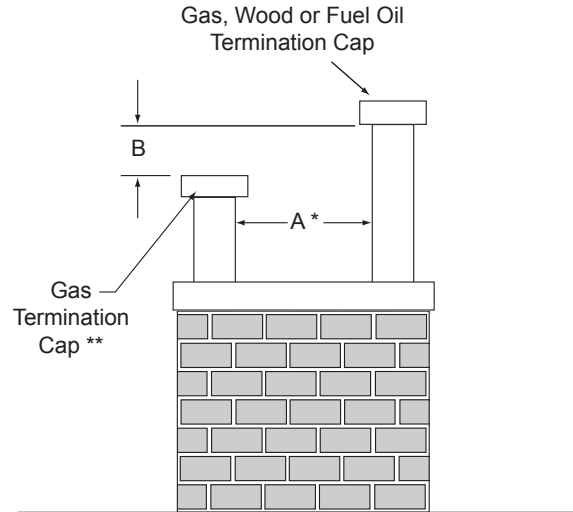

- * If using decorative cap cover(s), this distance may need to be increased. Refer to the installation instructions supplied with the decorative cap cover.
- ** In a staggered installation with both gas and wood or fuel oil terminations, the wood or fuel oil termination cap must be higher than the gas termination cap.

Figure 4.2 Staggered Termination Caps

B. Chimney Diagram

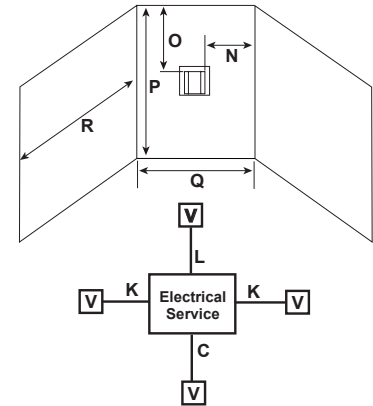
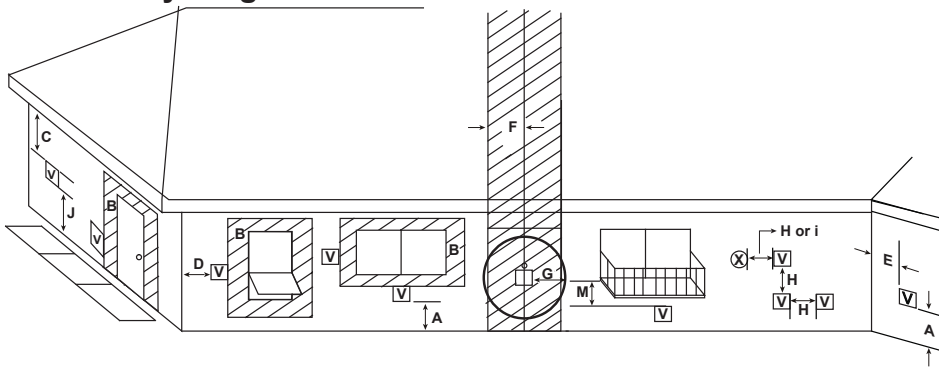

V = VENT TERMINAL **X** = AIR SUPPLY INLET
▨ = AREA WHERE TERMINAL IS NOT PERMITTED

- A clearances above grade, veranda, porch, deck or balcony
- | | PVLP-SLP | PVI-SLP |
|-----------|-----------|-----------|
| (PRIMO48) | 14 inches | 12 inches |
| (PRIMO60) | 16 inches | 12 inches |
| (PRIMO72) | 18 inches | 12 inches |
- B = 12 inches.....clearance to window or door that may be opened, or to permanently closed window
- C = 18 inches.....clearance below unventilated soffit
 18 inches.....clearance below ventilated soffit
 =18 inches (PVLP-SLP).....clearance below vinyl soffits and electrical service
 =30 inches (PVI-SLP)
- D = 6 inches.....clearance to outside corner
- E = 6 inches.....clearance to inside corner
- F = 3 ft. (Canada).....not to be installed above a gas meter/regulator assembly within 3 feet horizontally from the center-line of the regulator
- G = 3 ft.....clearance to gas service regulator vent outlet
- H = 9 inches (U.S.A)
 12 inches (Canada).clearance to non-mechanical (unpowered) air supply inlet, combustion air inlet or direct-vent termination
- i = 3 ft. (U.S.A.)
 6 ft. (Canada).....clearance to a mechanical (powered) air supply inlet
- All mechanical air intakes within 10 feet of a termination cap must be a minimum of 3 feet below termination.
- J = 7 ft..... On **public** property: clearance above paved sidewalk or a paved driveway.
- A vent shall not terminate directly above a sidewalk or paved driveway which is located between two single family dwellings and serves both dwellings.
- K = 6 inches.....clearance from sides of electrical service
 L = 12 inches.....clearance above electrical service
 Location of the vent termination must not interfere with access to the electrical service.
- M = 18 inchesclearance under veranda, porch, deck, balcony or overhang
 = 18 inches (PVLP-SLP)
 = 42 inches (PVI-SLP)vinyl or composite overhang
 Permitted when veranda, porch, deck or balcony is fully open on a minimum of 2 sides beneath the floor.

Covered Alcove Applications

(Spaces open only on one side and with an overhang)

- N = 6 inches non-vinyl sidewalls
 12 inches vinyl sidewalls
- O = 18 inches non-vinyl soffit and overhang
 = 18 inches vinyl soffit and overhang (PVLP-SLP)
 = 42 inches.....vinyl soffit and overhang (PVI-SLP)
- P = 8 ft.

	Q _{MIN}	R _{MAX}
1 cap	3 feet	2 x Q _{ACTUAL}
2 caps	6 feet	1 x Q _{ACTUAL}
3 caps	9 feet	2/3 x Q _{ACTUAL}
4 caps	12 feet	1/2 x Q _{ACTUAL}
Q _{MIN} = # termination caps x 3 R _{MAX} = (2 / # termination caps) x Q _{ACTUAL}		

MEASURE VERTICAL CLEARANCES FROM THIS SURFACE.

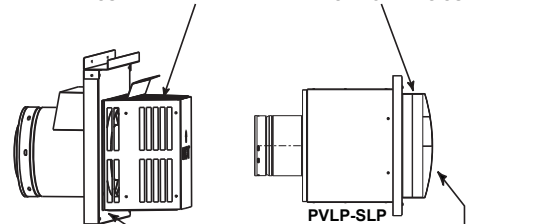

MEASURE HORIZONTAL CLEARANCES FROM THIS SURFACE.

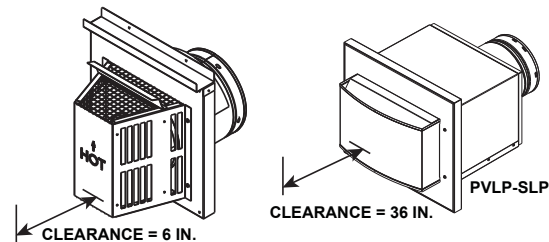

CAUTION! Risk of Burns! Termination caps are **HOT**, consider proximity to doors, traffic areas or where people may pass or gather (sidewalk, deck, patio, etc.). Listed cap shields available. Contact your dealer.

- Local codes or regulations may require different clearances.
- Vent system termination is **NOT** permitted in screened porches.
- Vent system termination is permitted in porch areas with two or more sides open.
- Hearth & Home Technologies assumes no responsibility for the improper performance of the appliance when the venting system does not meet these requirements.
- Vinyl protection kits are suggested for use with vinyl siding.

Figure 4.3 Minimum Clearances for Termination

C. Approved Pipe

This appliance is approved for use with Hearth & Home Technologies DVP or SLP venting systems. Refer to Section 12.A for vent component information and dimensions.

DO NOT mix pipe, fittings or joining methods from different manufacturers.

The pipe is tested to be run inside an enclosed wall. There is no requirement for inspection openings at each joint within the wall.

WARNING! Risk of Fire or Asphyxiation. This appliance requires a separate vent. **DO NOT** vent to a pipe serving a separate solid fuel burning appliance.

WARNING! Risk of Fire! PRIMO models must be power vented using PVI-SLP or PVLP-SLP and an installed PowerFlow™ Heat Management System. Failure to vent properly could cause overheating and fire.

D. Use of Elbows

Diagonal runs have both vertical and horizontal vent aspects when calculating the effects. Use the rise for the vertical aspect and the run for the horizontal aspect (see Figure 4.4).

Two 45° elbows may be used in place of one 90° elbow. On 45° runs, one foot of diagonal is equal to 8-1/2 in. (216 mm) horizontal run and 8-1/2 in. (216 mm) vertical run. A length of straight pipe is allowed between two 45° elbows. See Figure 4.4.

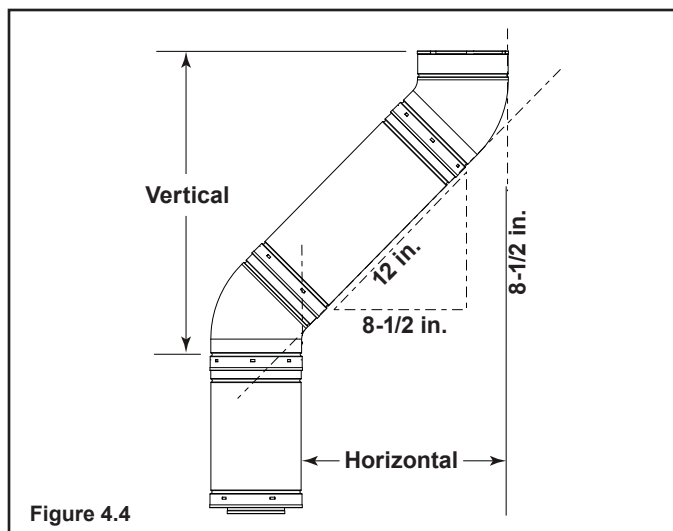

E. Measuring Standards

Vertical and horizontal measurements listed in the vent diagrams were made using the following standards:

- Pipe measurements are shown using the effective length of pipe. See Section 12.A for information on effective length of pipe components.
- Measurements are made from the factory-installed 6 inch DVP pipe, not from the standoffs.
- Horizontal terminations are measured to the outside mounting surface (flange of termination cap). See Figure 4.3.
- Vertical terminations are measured to bottom of termination cap.
- Horizontal pipe installed level with no rise.

F. Vent System and Diagrams

General Rules:

- When penetrating a combustible wall, a wall shield firestop must be installed.
- When penetrating a combustible ceiling, a ceiling firestop must be installed.
- Horizontal runs of vent do not require vertical rise; horizontal runs may be level.
- The PRIMO must be power vented using either a PVI-SLP system or a PVLP-SLP system.

WARNING! Risk of Fire! PRIMO models must be power vented using PVI-SLP or PVLP-SLP. Failure to vent properly could cause overheating and fire.

- The PRIMO comes standard with a 2 minute pre-purge function designed to remove gas from the appliance and establish a positive draft for the vent system.
- The PRIMO comes standard with a 20 minute post-purge function designed to eliminate condensation in the venting system components.
- Installation of a PowerFlow™ Heat Management System is required for the PRIMO.

⚠ WARNING



Fire Risk. Explosion Risk.
 Do NOT pack insulation or other combustibles between ceiling firestops.
 • ALWAYS maintain specified clearances around venting and firestop systems.
 • Install wall shield and ceiling firestops as specified.
 Failure to keep insulation or other material away from vent pipe could cause fire.



APPROVED VENT SYSTEMS

	HORIZONTAL TERMINATION	VERTICAL TERMINATION	DVP VENT COMPONENTS	SLP VENT COMPONENTS
PVI-SLP	ALLOWED	ALLOWED	ALLOWED	ALLOWED
PVLP-SLP	ALLOWED	NOT ALLOWED	ALLOWED	ALLOWED

APPROVED VENT MAXIMUMS

MODEL	VENT SYSTEM	MAX. TOTAL VENT RUN (FT.)**	MAX. 90° ELBOWS	MAX. VERT. DROP (FT.)
PRIMO48 PRIMO48ST	PVI-SLP	60	6	12*
	PVLP-SLP	60	6	12*
PRIMO60 PRIMO60ST	PVI-SLP	50	5	9*
	PVLP-SLP	50	5	9*
PRIMO72 PRIMO72ST	PVI-SLP	40	4	9*
	PVLP-SLP	40	4	9*

ADAPTER KITS

PART NUMBER	PART DESCRIPTION
DVP-2SL (Included with PRIMO)	Adapts from 8 in. DVP-series starting collars to 6-5/8 in. SLP series vent pipe.
DVP-SLP24	Adapts from 8 in. DVP-series starting collars to 6-5/8 in. SLP series vent pipe.

WARNING! Risk of Fire! Vertical termination is **NOT** allowed with PVLP-SLP. Fire could occur.

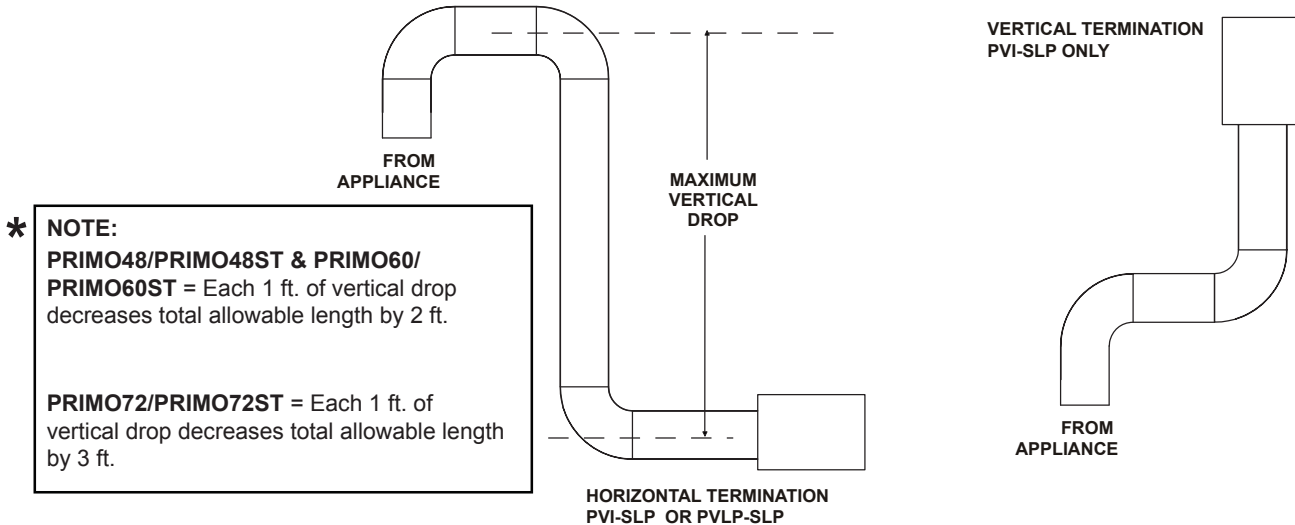

NOTE: Maximum total vent run= Total vertical vent run + Total horizontal vent run
****=** Horizontal termination allowed with both PVI-SLP and PVLP-SLP

NOTICE: If a pipe configuration includes a vertical component that goes downward, a vertical component going back upward is not allowed. Condensation will occur.

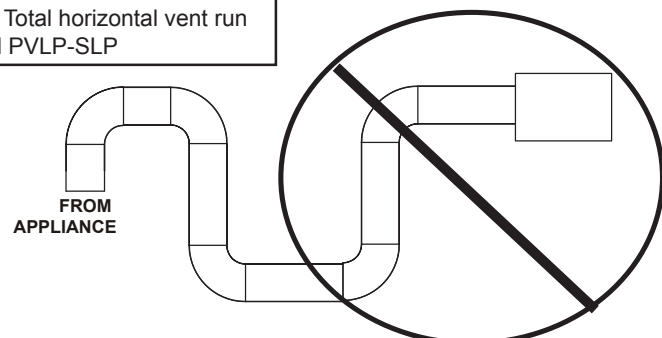

Figure 4.5

G. Power Vent Baffle Adjustment

PVI-SLP Baffle Adjustment

The PVI-SLP has a baffle adjustment which must remain set in the closed position. This baffle adjustment is located alongside the motor. The baffle adjustment is measured using the holes on the indicator bar of the PVI-SLP baffle. This bar raises as the baffle is opened and lowers as the baffle is closed. When only one hole is showing, the baffle is closed. The PRIMO requires that the baffle MUST remain set in the CLOSED position as indicated in Figure 4.6.

For more information regarding installation of the PVI-SLP, refer to the instruction included with that accessory.

CAUTION! Risk of Overheating! Set and secure baffle indicator as instructed. Overheating could occur causing appliance to shut down.

PRIMO48/PRIMO48ST (NG) Only:

Baffle Setting Exception: Due to the tendency of air to move more quickly through the power vent in a smaller size appliance, the PRIMO48/PRIMO48ST may require a “two-hole” setting instead of being closed. If the pilot is unstable, adjust the baffle. See the PVI-SLP installation instructions for baffle adjustment information.

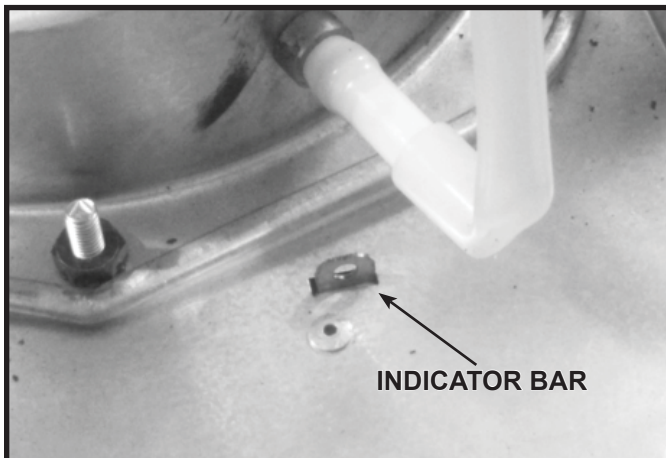

Figure 4.6 PVI-SLP Baffle Indicator

PVLP-SLP Baffle Adjustment

The PVLP-SLP baffle is closed when the locking screw remains installed. The PRIMO requires that the baffle MUST remain in the CLOSED position as indicated in Figure 4.7.

For more information regarding installation of the PVLP-SLP, refer to the instruction included with that accessory.

PRIMO48/PRIMO48ST (NG) Only:

Baffle Setting Exception: Due to the tendency of air to move more quickly through the power vent in a smaller size appliance, the PVLP-SLP baffle may need to be opened up no more than 1/2 inch on the PRIMO48 and PRIMO48ST. If the pilot is unstable, adjust the baffle. See the PVI-SLP installation instructions for baffle adjustment information.

CAUTION! Risk of Overheating! DO NOT remove the locking screw on the baffle. Appliance could overheat.

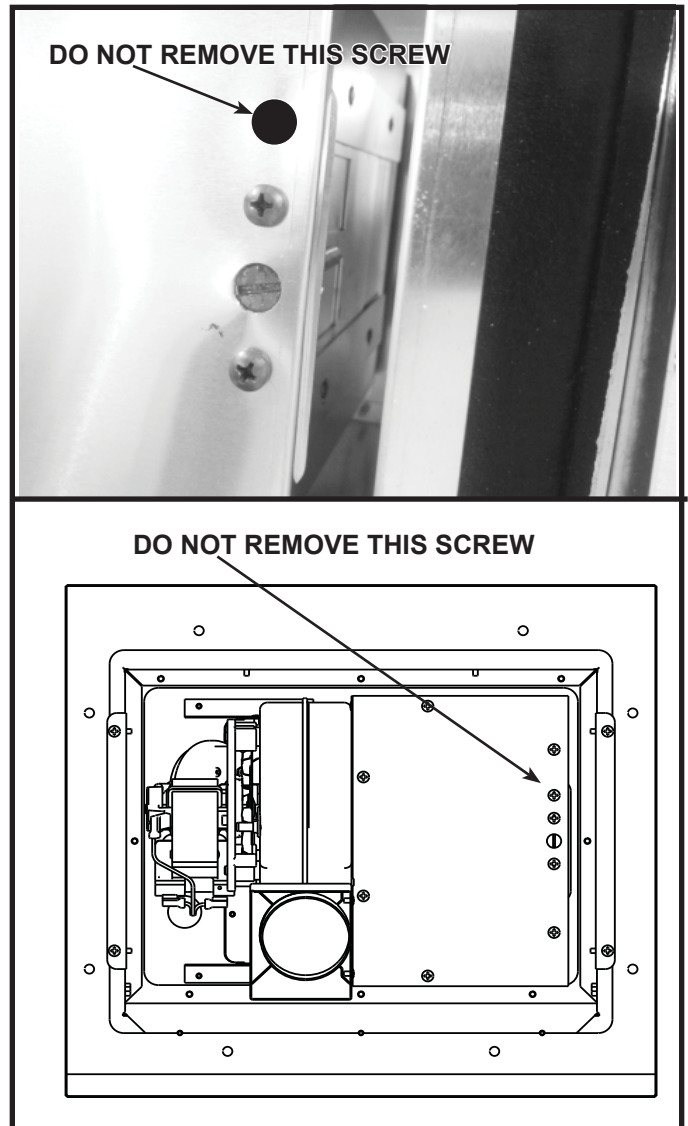

Figure 4.7 PVLP-SLP Baffle Locking Screw

5 Vent Clearances and Framing

A. Pipe Clearances to Combustibles

WARNING! Risk of Fire! Maintain air space clearance to vent. DO NOT pack insulation or other combustibles:

- Between ceiling firestops
- Between wall shield firestops
- Around vent system

Failure to keep insulation or other material away from vent pipe could cause overheating and fire.

- These clearances to combustibles override the clearances noted in the PVI-SLP installation instructions.
- Clearance above an elbow is 3 inches unless 3 feet of vertical pipe is installed between the 6 inch factory-installed pipe section and the first elbow. After 3 feet of vertical pipe is installed, the clearance is 1-1/2 inches.

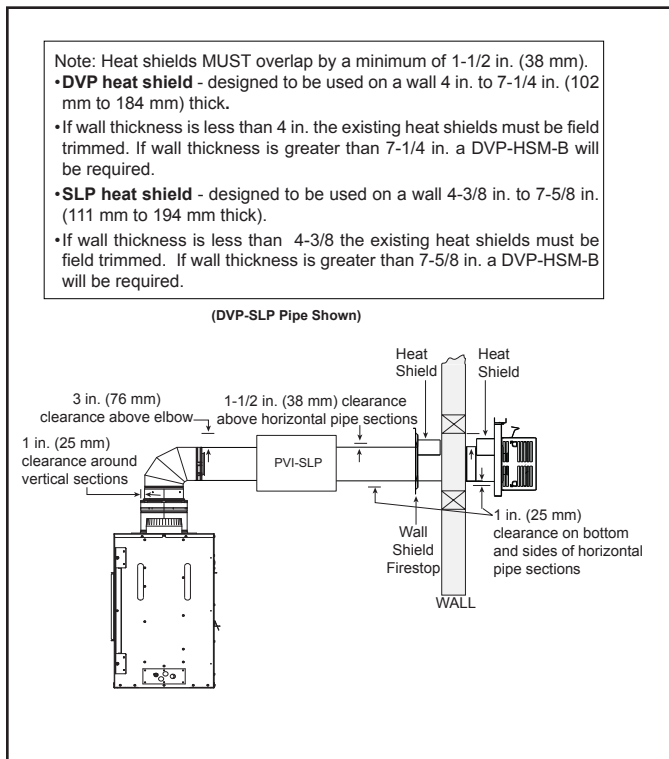

Figure 5.1 Horizontal Venting Clearances To Combustible Materials (PVI-SLP)

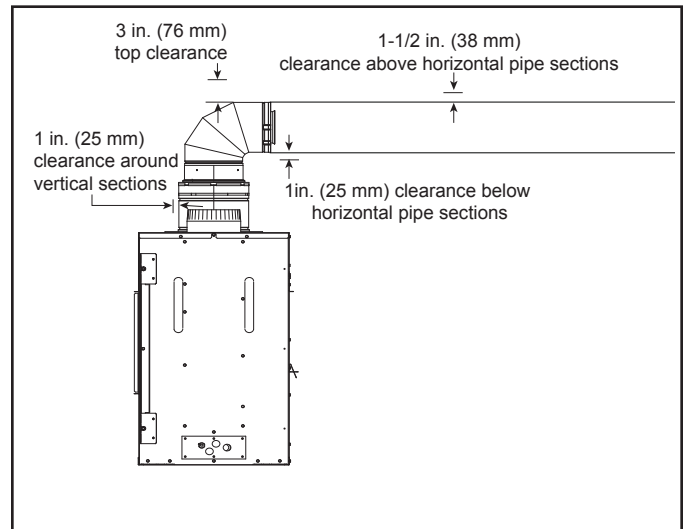

Figure 5.2 Clearances - Elbow Directly Off Top of Appliance (PVI-SLP/PVLP-SLP)

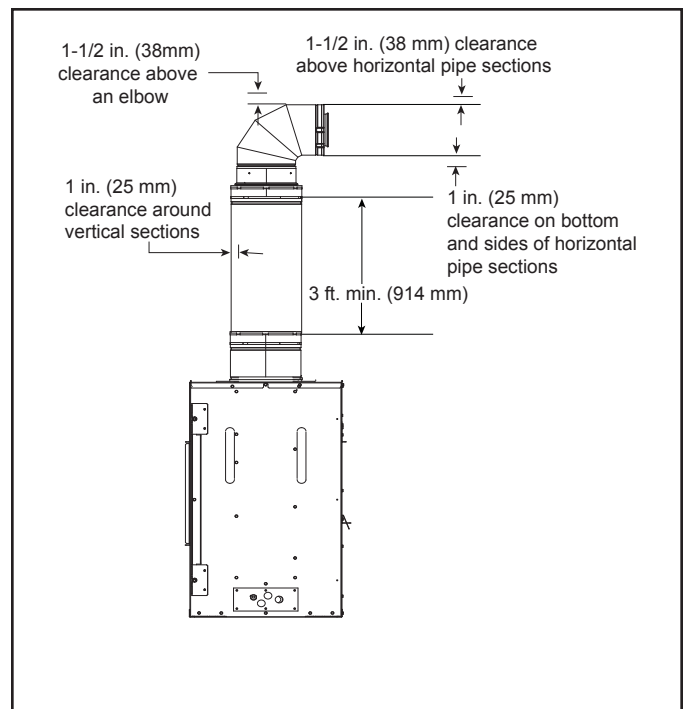

Figure 5.3 Clearances - 3 Feet of Vertical Pipe Before an Elbow (PVI-SLP/PVLP-SLP)

B. Wall Penetration Framing/Firestops

Combustible Wall Penetration

Whenever a combustible wall is penetrated, you must frame a hole for the wall shield firestop(s). The wall shield firestop maintains minimum clearances and prevents cold air infiltration.

- The opening must be framed on all four sides using the same size framing materials as those used in the wall construction.
- SLP pipe - A wall shield firestop must be placed on each side of an interior wall. A minimum 1-1/2 in. (38 mm) overlap of attached heat shields must be maintained.
- DVP pipe - A wall shield firestop is required on one side only on interior walls. If your local inspector requires a wall shield firestop on both sides, then both wall shield firestops must have a heat shield (refer to Section 12.A.) attached to them.
- See instructions included with PVL-PSLP and PVI-PSLP for clearance information.
- See Section 7.F. for information for regarding the installation of a horizontal termination cap.

Non-Combustible Wall Penetration

If the hole being penetrated is surrounded by non-combustible materials such as concrete, a hole with diameter one inch greater than the pipe is acceptable.

Whenever a non-combustible wall is penetrated, the wall shield firestop is only required on one side and no heat shield is necessary.

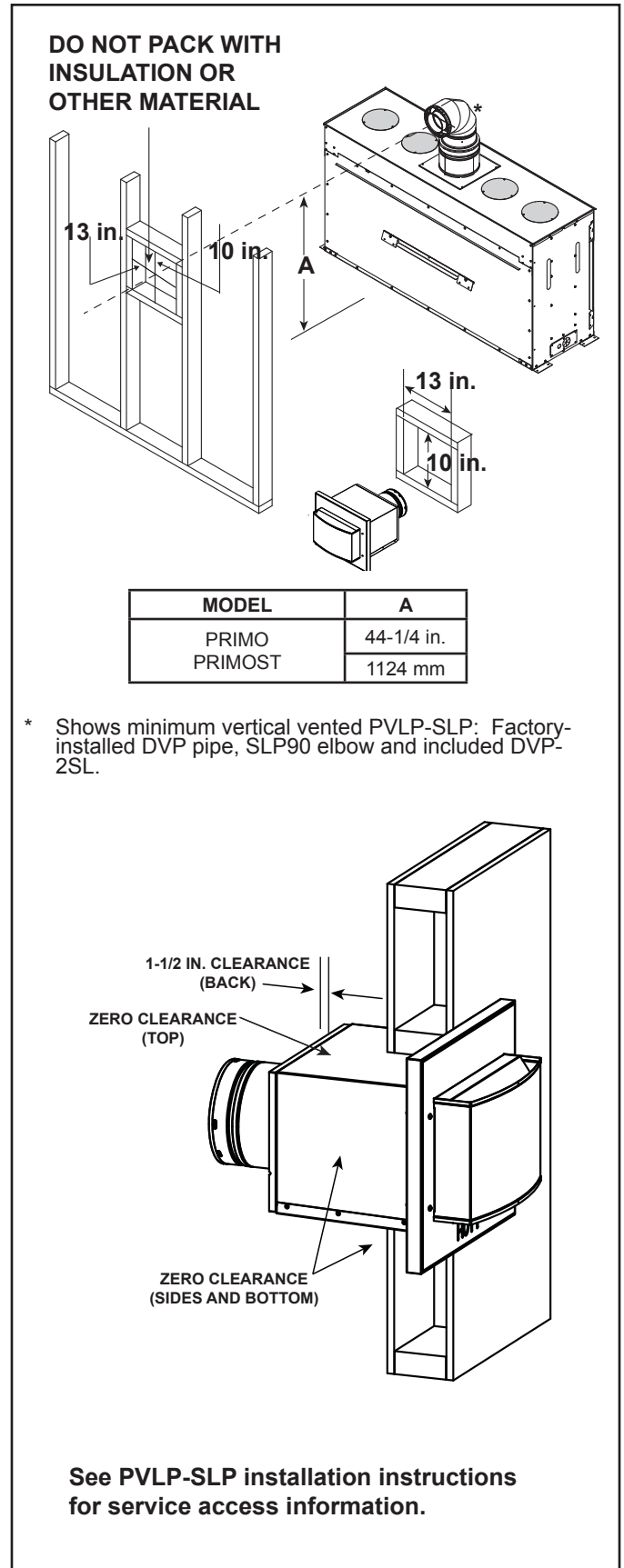

Figure 5.4 Wall Penetration (PVL-PSLP)

C. Ceiling Firestop/Floor Penetration Framing

A ceiling firestop **MUST** be used between floors and attics.

- **DVP pipe only** - Frame an opening 10 in. by 10 in. (254 mm by 254 mm) whenever the vent penetrates a ceiling/floor. See Figure 5.5.
- **SLP pipe only** - Frame opening 9 in. x 9 in. (229 mm x 229 mm) whenever the vent penetrates a ceiling/floor.
- Frame the area with the same sized lumber as used in ceiling/floor joist.
- The ceiling firestop may be installed above or below the ceiling joists when installed with an attic insulation shield. It must be under joists between floors that are not insulated. Refer to Figure 5.6.
- Secure in place with nails or screws.

WARNING! Risk of Fire! DO NOT pack insulation around the vent. Insulation must be kept back from the pipe to prevent overheating.

D. Install Attic Insulation Shield

WARNING! Fire Risk. DO NOT allow loose materials or insulation to touch vent. Hearth & Home Technologies requires the use of an attic shield.

The International Fuel Gas Code requires an attic shield constructed of 26 gauge minimum steel that extends at least 2 in. (51 mm) above insulation.

- Attic insulation shields must meet specified clearances to combustible materials and be secured in place.
- An attic insulation shield kit is available from Hearth & Home Technologies. Contact your dealer to order. Install attic insulation shield according to instructions included with kit.

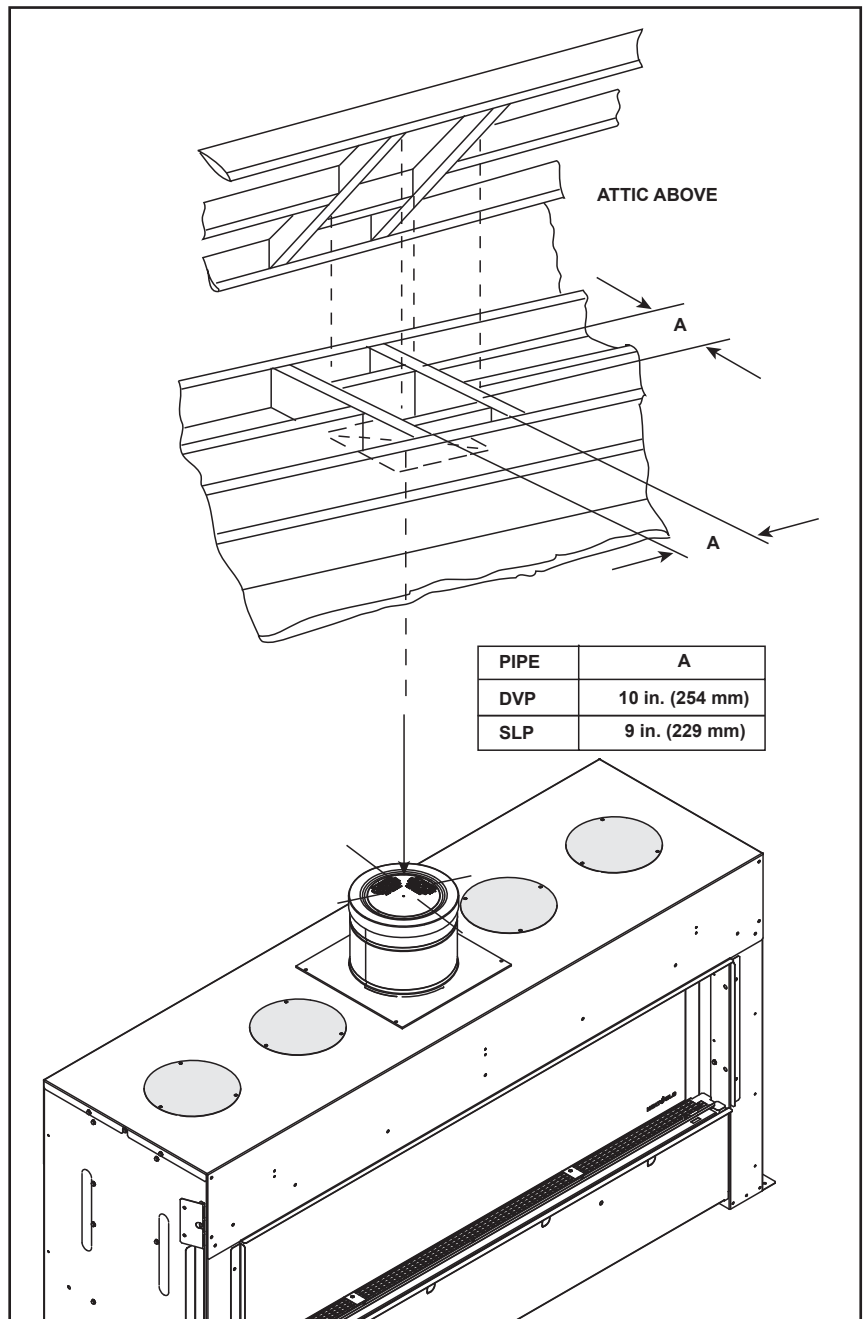

Figure 5.5 Installing Ceiling Firestop

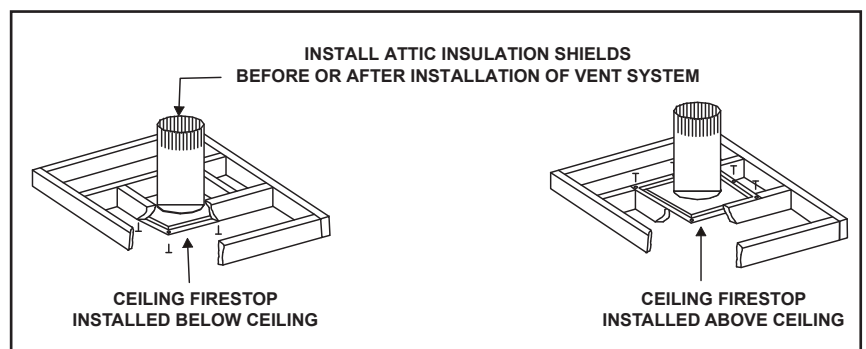

Figure 5.6 Installing the Attic Shield

6 Appliance Preparation

A. Vent Collar Preparation

CAUTION! Risk of Cuts, Abrasions or Flying Debris. Wear protective gloves and safety glasses during installation. Sheet metal edges are sharp.

The PRIMO is shipped standard with an attached DVP pipe section. Do not remove. When SLP pipe will be used for venting, the included DVP-2SLP adaptor can be used to make the conversion from DVP pipe to SLP pipe.

1. Place the 1/8 inch thick, square pipe gasket over the initial six inch vent section.
2. Secure square pipe gasket with four screws.
3. Attach the included DVP-2SL to the vent system with the two screws.

Note: The DVP-2SL may be installed at any point within the appliance venting system.

Note: DO NOT remove installed DVP pipe section. Use DVP-2SL to convert for use with SLP pipe.

4. Select one or both of the two required PowerFlow™ Heat Management Systems:

- Heat Zones (Quantity 2 included in kit)
(HEAT-ZONE-PRIMO)
- Heat Out
(HEAT-OUT-PRIMO)

Remove only one of the two seal plates if installing the HEAT-OUT-PRIMO. The other HEAT-OUT-PRIMO plate must remain in the factory-installed position.

WARNING! Risk of Overheating! Remove only one seal plate to install HEAT-OUT-PRIMO. Appliance will overheat.

WARNING! Risk of Fire! DO NOT remove PowerFlow™ Heat Management seal plate unless a PowerFlow™ Heat Management System will be connected at that location. Appliance will overheat.

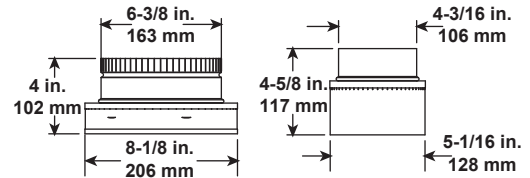

DVP-2SL
Adapter (Included)

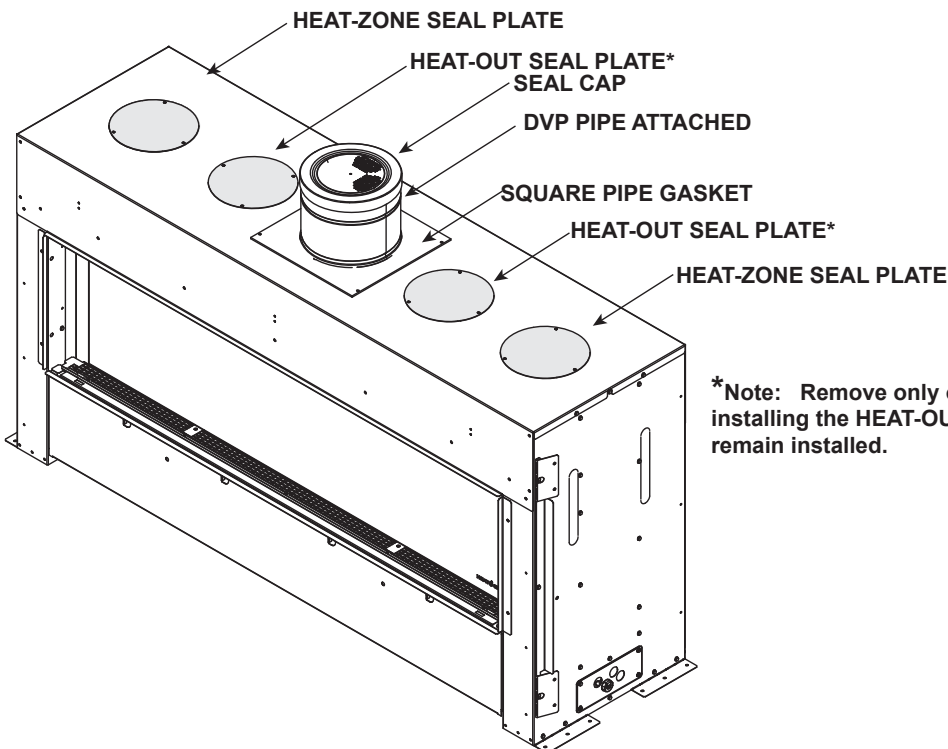

*Note: Remove only one of the two middle seal plates if installing the HEAT-OUT-PRIMO. The other plate must remain installed.

Figure 6.1 Vent Collar Preparation

B. Securing and Leveling the Appliance

WARNING! Risk of Fire! Prevent contact with:

- Sagging or loose insulation
- Insulation backing or plastic
- Framing and other combustible materials

Block openings into the chase to prevent entry of blown-in insulation. Make sure insulation and other materials are secured.

Failure to maintain air space clearance could cause overheating and fire.

To properly position, level, and secure the appliance, see below. Nailing tabs are provided to secure the appliance to the framing members.

- Bend out the two nailing tabs on each side.
- Place the appliance into position.
- Keep nailing tabs flush with the framing. See Figure 6.2.
- Level the appliance from side to side and front to back.
- Shim the appliance as necessary. It is acceptable to use wood shims underneath the appliance.
- Secure the appliance to the framing by using nails or screws through the nailing tabs.

Some figures in manual show the fireplace installed on the floor. However, this fireplace can be elevated off the floor provided that the fireplace is properly supported by framing materials and the ceiling clearances are maintained.

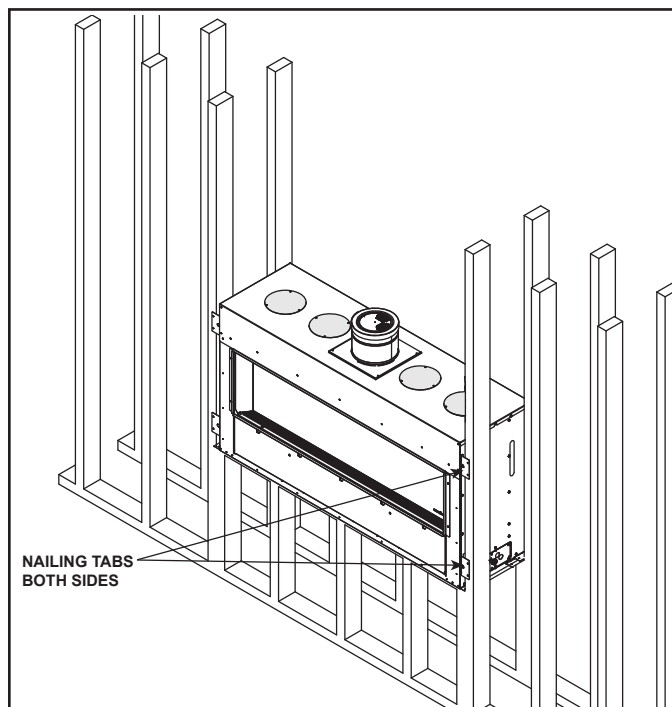

Figure 6.2 Nailing Tab Locations

Setting the Fireplace into the Framing

The left and right nailing tabs were designed as a means to ensure the fireplace is mounted flush with the framing materials. See Figures 6.2-6.4

1. The shipping flanges protrude further out from the appliance than the side standoffs. The shipping flange may be bent upward or broken off in order to place the appliance into position in the framing.
2. Bend out all nailing tabs. The see-through model will have eight nailing tabs. The single-sided model will have four nailing tabs.
3. Screw each nailing tab to the adjoining framing material. Ensure that the one inch air space clearance is maintained on the sides and back of the fireplace. See Figures 3.5-3.8 for framing and clearance details.

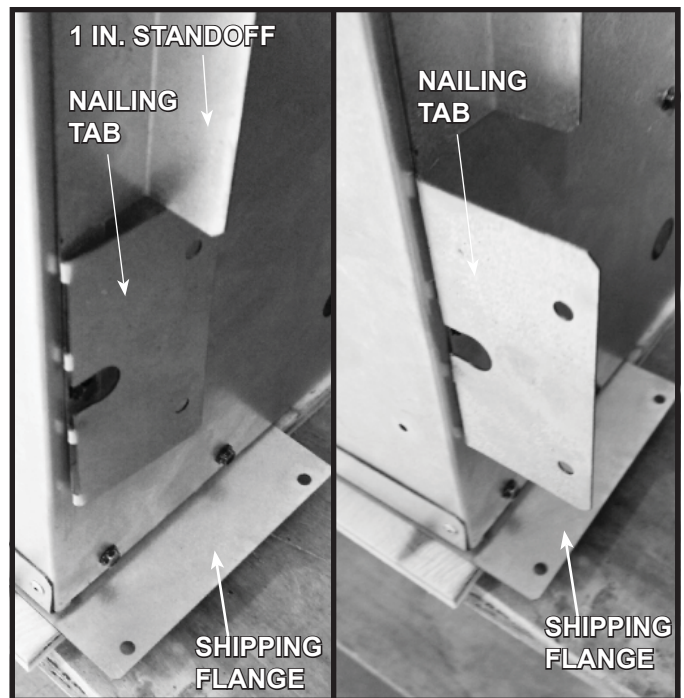

Figure 6.3 Nailing Tabs Shipping Position

Figure 6.4 Nailing Tabs Installation Position

C. HEAT-ZONE-PRIMO

WARNING! Risk of Fire! Either the HEAT-ZONE-PRIMO and/or the HEAT-OUT-PRIMO PowerFlow™ Heat Management System must remain ON during operation of the appliance. Overheating will occur. Appliance will shut down.

Introduction

The HEAT-ZONE-PRIMO PowerFlow™ Heat Management System conveys warm air from the fireplace through air ducts to remote locations in the same room or other rooms in the building. Two HEAT-ZONE-PRIMO's must be installed with the PRIMO appliance or the appliance will overheat. Two HEAT-ZONE-PRIMO's are included in the kit.

Approvals

The flexible duct used with the HEAT-ZONE-PRIMO is manufactured and marked to the requirements of UL-181, Class I air duct.

Operation

The HEAT-ZONE-PRIMO PowerFlow™ Heat Management System is powered by a thermo switch. The system will turn on approximately 10 minutes after the appliance is turned on. The HEAT-ZONE-PRIMO accessory is tested and safe when installed in accordance with this installation manual. It is your responsibility to read all instructions before starting installation and to follow these instructions carefully during installation.

Installation of this kit **MUST** be performed by a qualified service technician.

The HEAT-ZONE-PRIMO is carefully engineered and must be installed only as specified. If you modify it or any of its components you will void the warranty, and you may possibly cause a fire hazard. Installation must be done according to applicable local, state, provincial, and/or national codes.

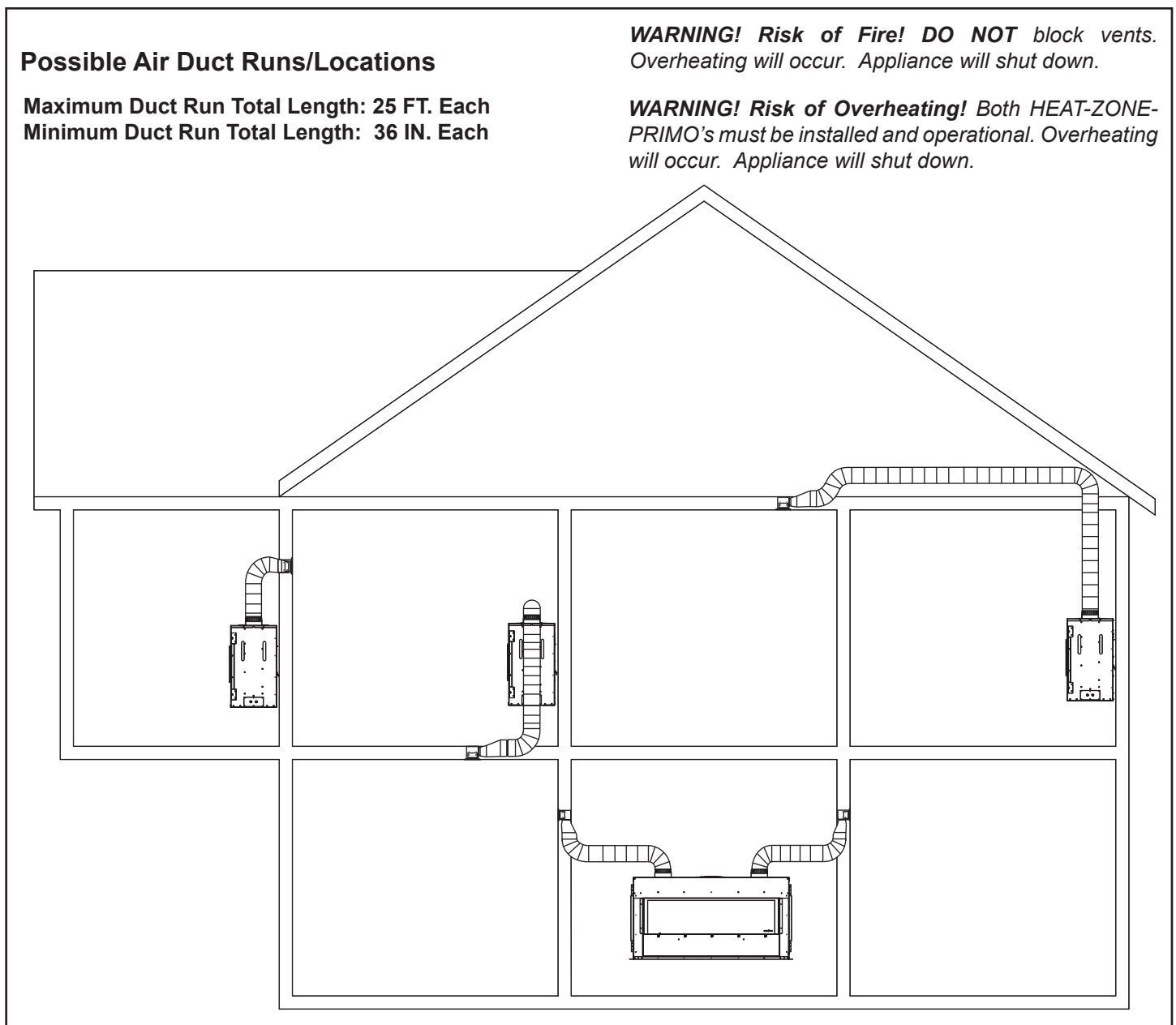

Figure 6.5 HEAT-ZONE-PRIMO Locations

Preliminary Preparation

Contents of HEAT-ZONE-PRIMO

CAUTION! Do not install damaged components.

If any parts are missing or damaged, contact your dealer before starting installation. **DO NOT** install a damaged kit.

DESCRIPTION	SERVICE PART NO.	QTY
6 in. Round Duct	659-200	2
Fan Housing Assembly	659-001A	2
Junction Box	659-122	2
Air Register	659-150	2
Register Adaptor Frame	659-125	2
Duct Adaptor (Round to Oval)	659-129	2
Gear Clamp: Large	662-803	4



659-200 6 INCH ROUND DUCT

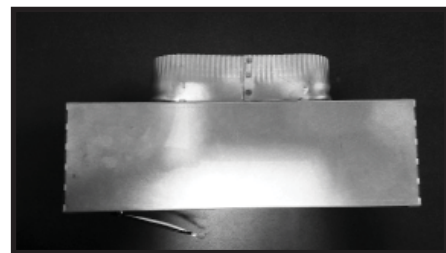

659-001A

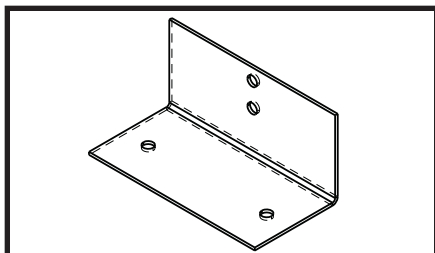

MOUNTING BRACKET
(Not a service Part)

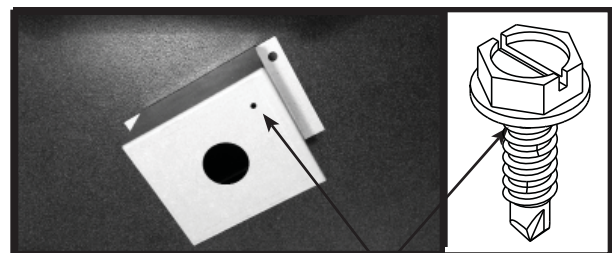

659-122 SILVER GROUND SCREW

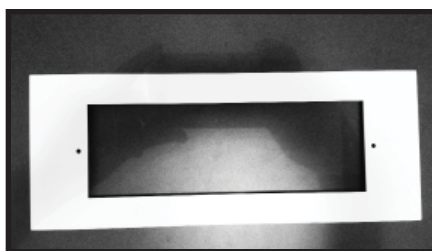

659-125 REGISTER ADAPTER FRAME

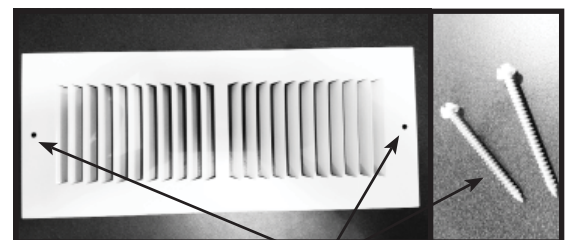

659-150 WHITE REGISTER SCREWS



662-803 GEAR CLAMP: LARGE



659-129 DUCT ADAPTER: ROUND TO OVAL

Figure 6.6 HEAT-ZONE-PRIMO Components

- Install the HEAT-ZONE-PRIMO collars on the left and right sides of the appliance with screws. See Figure 6.7.
- Attach included air duct to the HEAT-ZONE-PRIMO collars with gear clamps. See Figure 6.8.
- Attach both mounting brackets to the fan housing. See Figure 6.8.
- Mount fan housing in desired location. See Figures 6.5, 6.10 and 6.11.
- Attach round to oval adapter to fan housing with two screws. See Figure 6.8.
- Attach included flexible ducts to round to oval adapter with gear clamps.

Note: 6 Inch metal duct can be used in place of the included flexible ducts.

WARNING! Risk of Fire! HEAT-OUT-PRIMO seal plates MUST remain installed. Appliance could overheat.

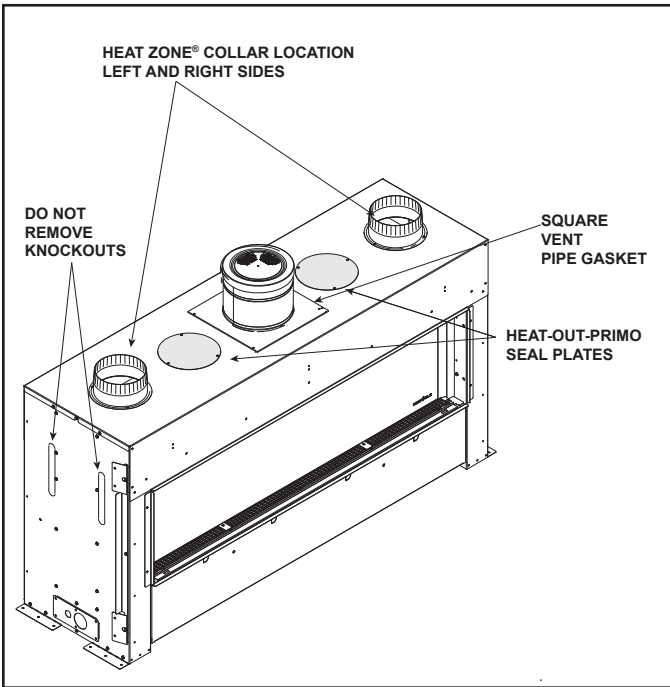

Figure 6.7 HEAT-ZONE-PRIMO

WARNING! Risk of Fire! DO NOT fold/kink/pinch/obstruct 6 inch flexible ducts. Appliance could overheat.

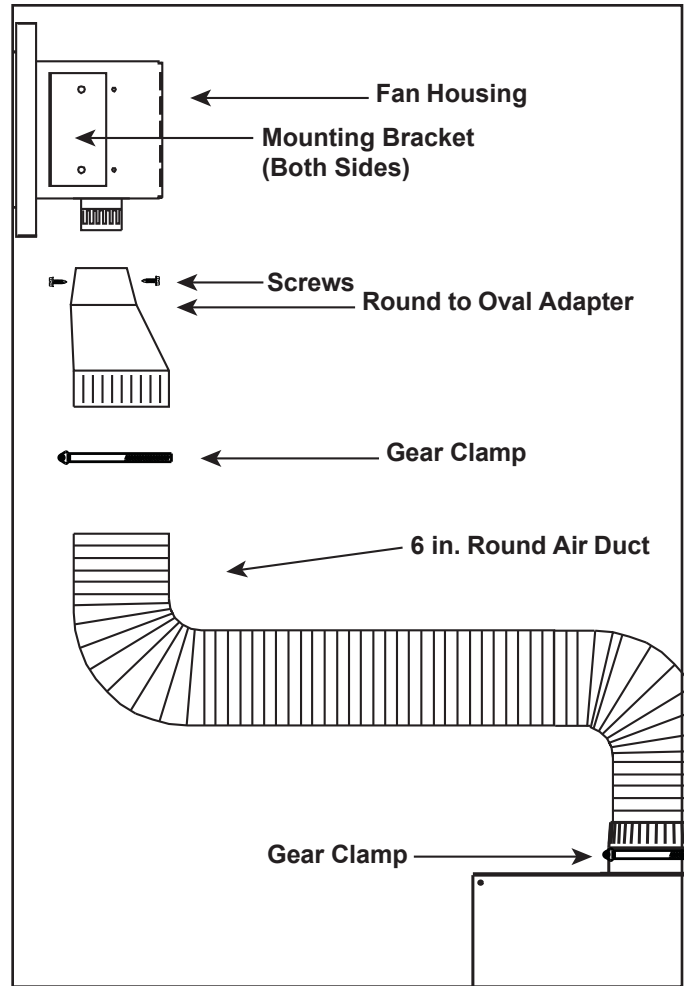

Figure 6.8

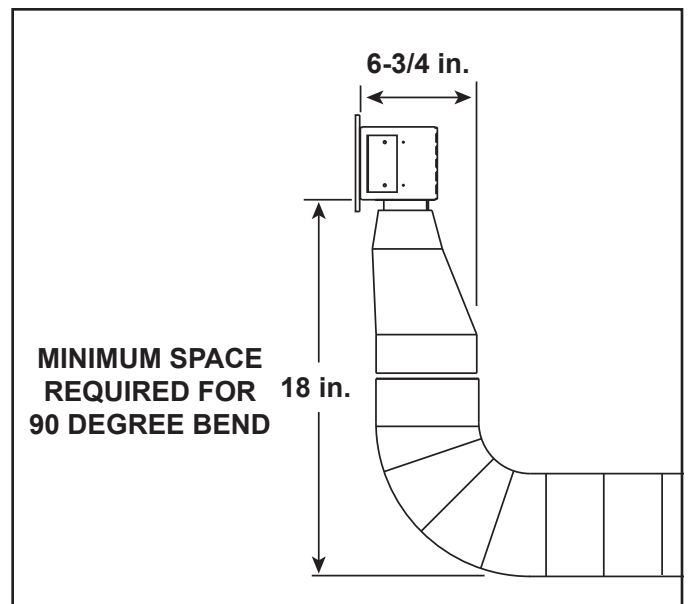

Figure 6.9

WARNING! Risk of Fire! The PowerFlow™ Heat Management system must remain ON during operation of the appliance. Overheating will occur. The appliance will shut down if the heat management systems are not operational.

The HEAT-ZONE-PRIMO PowerFlow™ Heat Management System conveys warm air from the fireplace through air ducts to remote locations in the same room or other rooms in the building. Two Heat-Zones must be installed with the Primo appliance or the appliance will overheat. Two HEAT-ZONE-PRIMO's are included in the kit.

Fan Housing Assembly Installation

Note: The fan and electrical connections must be accessible for servicing per local code requirements.

2 X 6 Wall Mounting

Mount and secure the fan housing assembly to framing members so the front surface is 1/4 -in. (6 mm) below the finished wall. Use the adjustable mounting brackets and screws provided in the kit. See Figure 6.10.

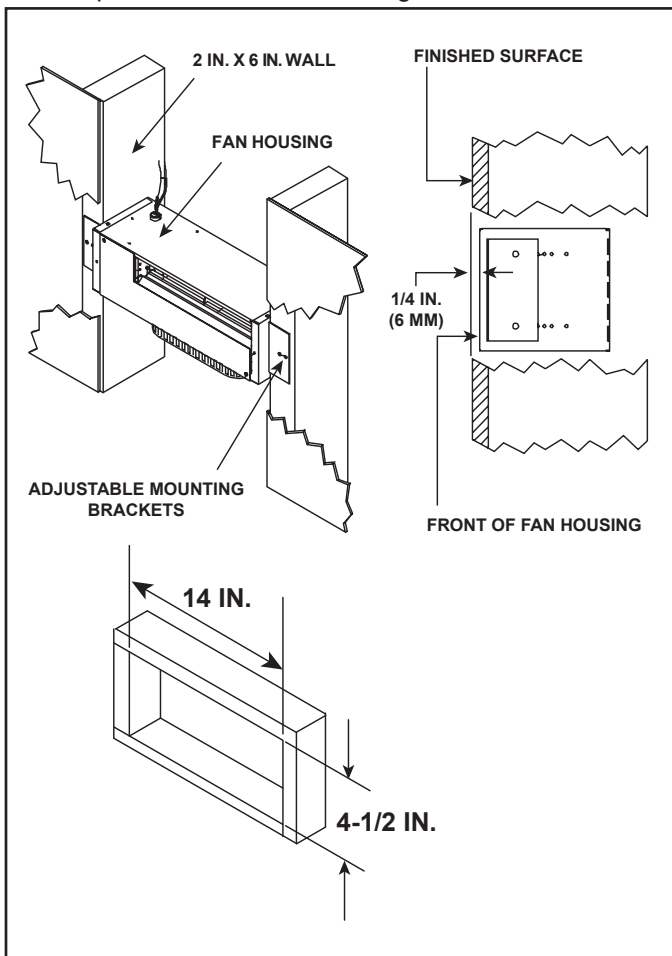

→ Figure 6.10 Wall Mounting (2 X 6)

2 X 4 Wall Mounting

Note: The brackets can be rotated 180° and mounted to the back side of the 2 x 4 if necessary. See Figure 6.11.

If the fan housing is installed in a 2 x 4 wall, the front of the housing will protrude approximately 1/2 in. (13 mm) out of the wall. See Figure 6.11.

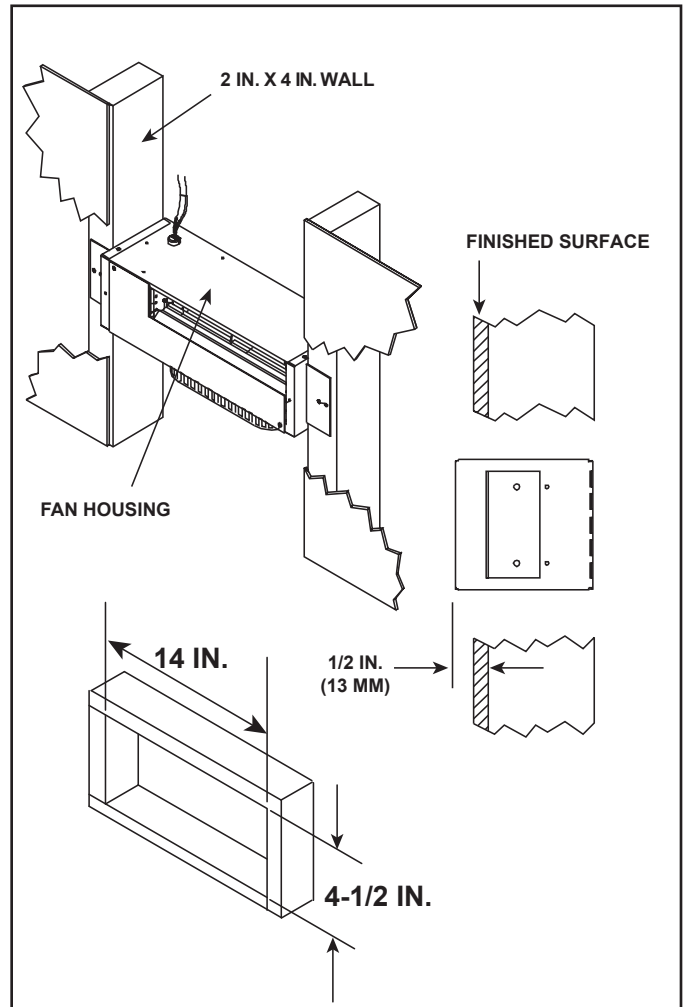

Figure 6.11 Wall Mounting (2 X 4) ←

Other Duct Options

Metal Oval Air Duct: Attach the round-to-oval adapter to the HEAT-ZONE-PRIMO collar with screws. Attach the 6" oval duct to the adapter with screws. Complete the duct run and attach the oval duct to the fan housing. **Note:** 6 in. metal oval duct is NOT provided with the HEAT-ZONE-PRIMO kit, but can be purchased from an HVAC supplier.

Metal Round And Oval Duct: A combination of 6 in. round and 6 in. oval air duct can be used in the duct run. Metal duct components may be purchased from an HVAC supplier.

Note: Support duct at intervals of no greater than four feet, with no more than 1/2 in. sag between supports as required by local code. Tape all seams with aluminum tape (1-1/4 in. minimum width, or as specified by local codes).

CAUTION! Risk of Overheating! Tape seams to prevent overheating and shut down of appliance.

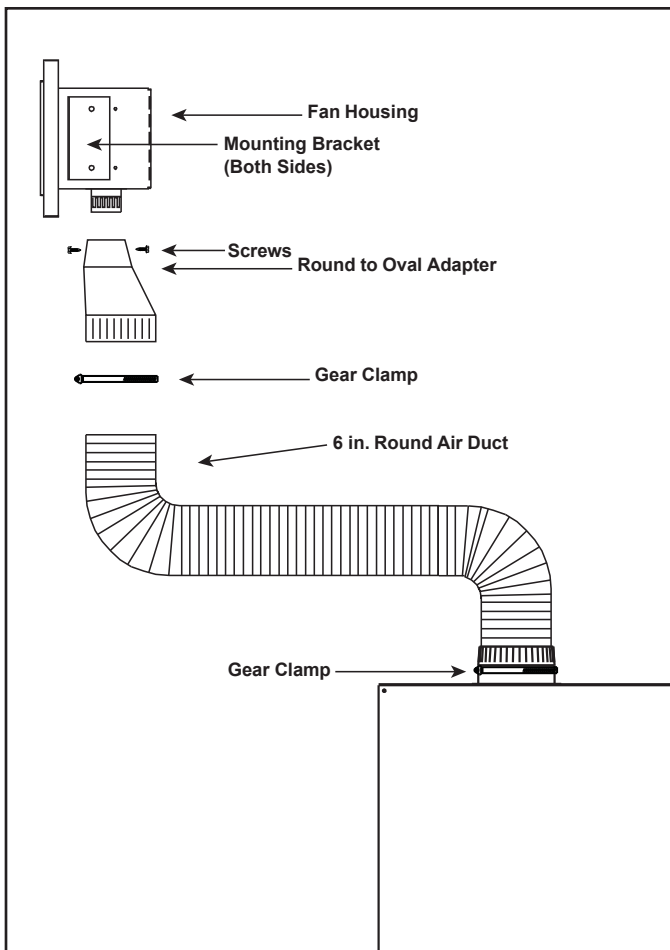

Figure 6.12

Plan the location of the fireplace and the warm air duct run(s).

Electrical Connections

Wire 110-120 VAC service from the appliance to the junction box. See Figure 6.13. Use wire nuts to secure the 110-120VAC service wires to the hot and neutral fan wires and screw the 110-120 VAC ground wire to the fan box. See Wiring Diagram in section 8 of the appliance manual.

Screw the duct cover to the fan box.

Screw the register adapter frame and the air register to the fan housing.

Complete the fireplace installation per instructions.

NOTICE: This appliance must be electrically wired and grounded in accordance with local codes or, in the absence of local codes, with **National Electric Code ANSI/NFPA 70-latest edition** or the **Canadian Electric Code CSA C22.1**.

Maintenance

Service and maintain the gas fireplace per instructions. Keep the air register(s) clean and free of any blockage.

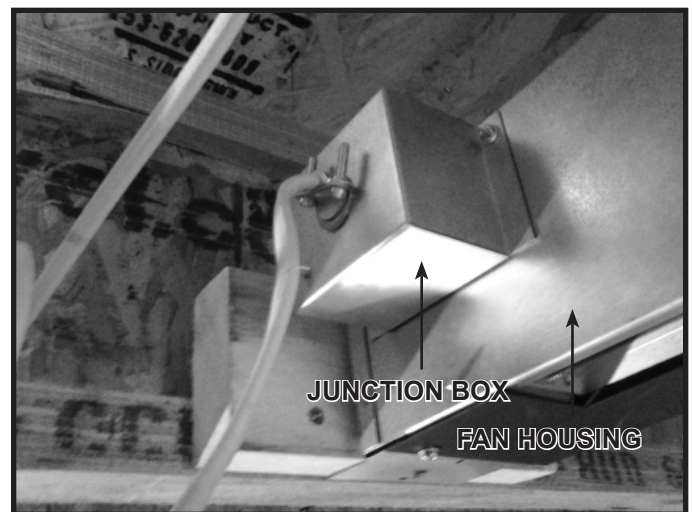

Figure 6.13

HEAT-ZONE-PRIMO Feature - Configuration

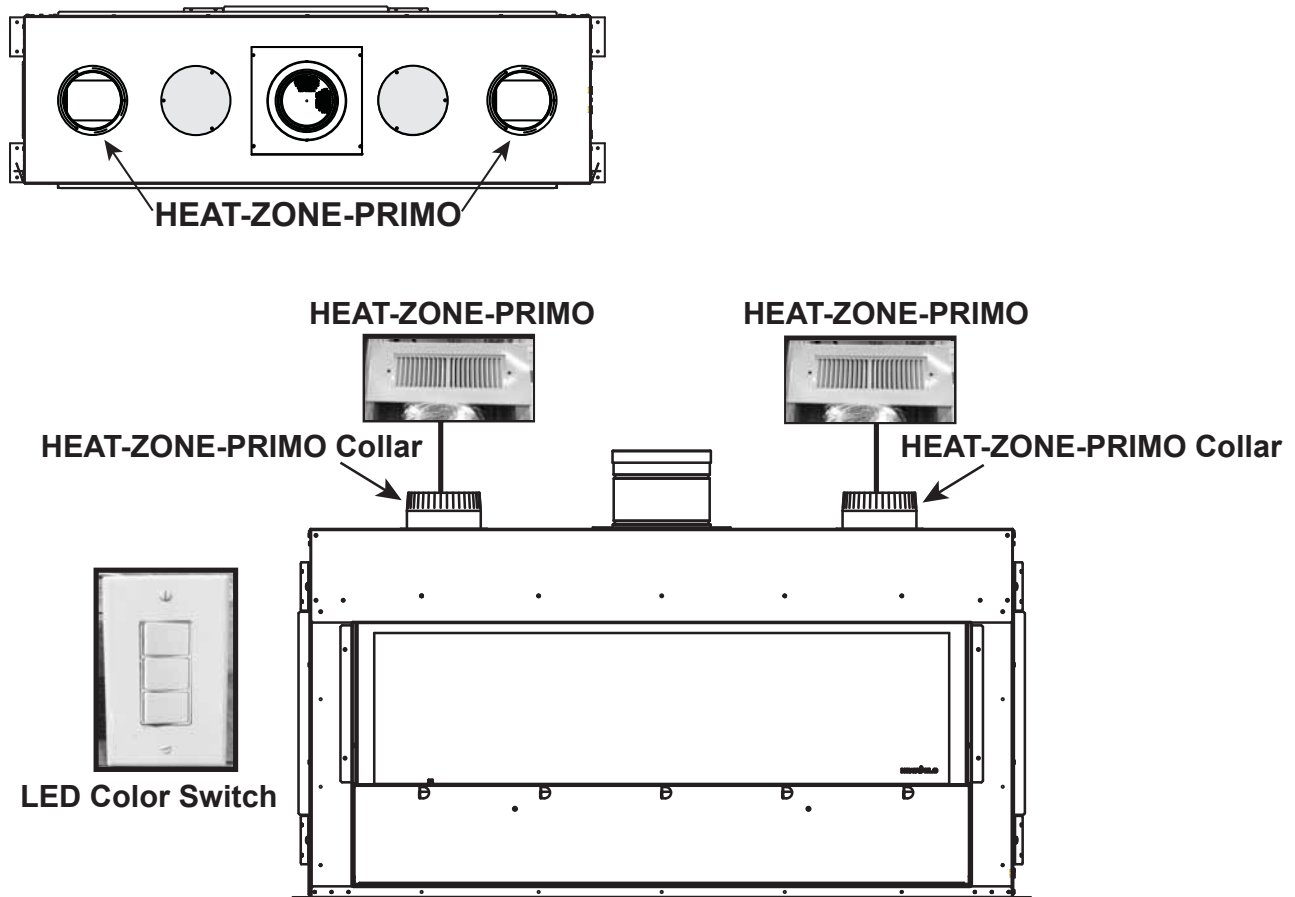

Figure 6.14. HEAT-ZONE-PRIMO Configuration

WARNING! Risk of Fire! Either the HEAT-ZONE-PRIMO and/or the HEAT-OUT-PRIMO PowerFlow™ Heat Management system must remain ON during operation of the appliance. Overheating will occur. Appliance will shut down.

D. HEAT-OUT-PRIMO

WARNING! Risk of Fire! Either the HEAT-ZONE-PRIMO and/or the HEAT-OUT-PRIMO Power Flow™ Heat Management system must remain ON during operation of the appliance. Overheating will occur. Appliance will shut down.

Introduction

The HEAT-OUT-PRIMO PowerFlow™ Heat Management System is designed to remove heat from your appliance and redirect outside the building.

Approvals

The flexible ducts used with the HEAT-OUT-PRIMO feature is manufactured and marked to the requirements of UL-181, Class I air duct.

Note: Appliance will shut down if the HEAT-OUT-PRIMO PowerFlow™ Heat Management System is not operating. Contact your dealer if automatic shutdown occurs.

Operation

The HEAT-OUT-PRIMO accessory is tested and safe when installed in accordance with this installation manual. It is your responsibility to read all instructions before starting installation and to follow these instructions carefully during installation.

Installation of this kit **MUST** be performed by a qualified service technician. After a qualified service technician has installed the appliance, including the HEAT-OUT-PRIMO PowerFlow™ Heat Management System, follow the instructions supplied with the appliance manual for operation. Contact your dealer if you have questions.

The HEAT-OUT-PRIMO feature is carefully engineered and must be installed only as specified. If you modify it or any of its components you will void the warranty, and you may possibly cause a fire hazard. Installation must be done according to applicable local, state, provincial, and/or national codes.

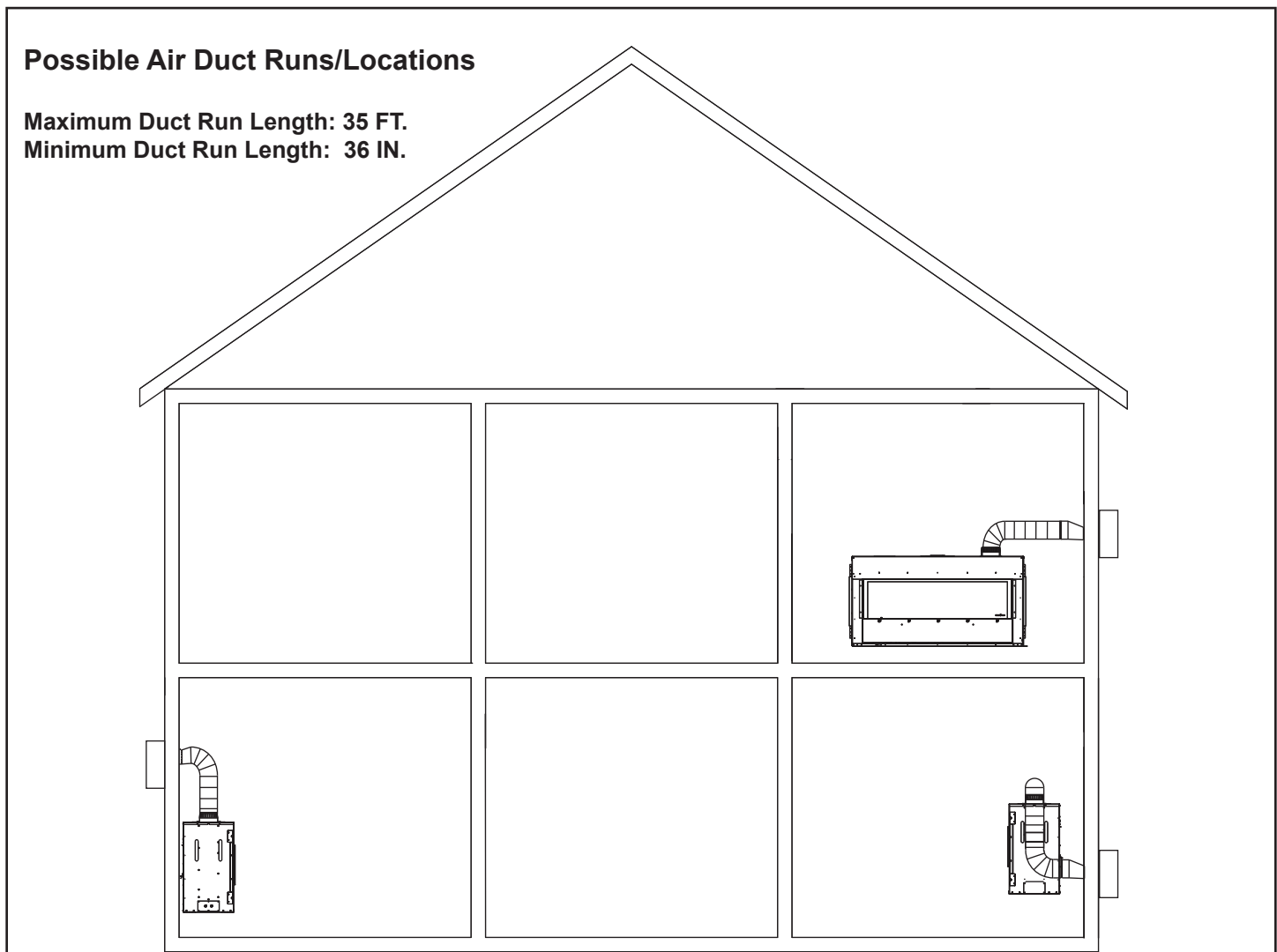
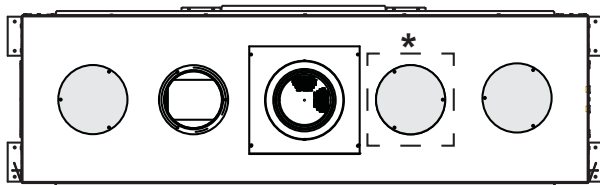

Figure 6.15. HEAT-OUT-PRIMO Locations

HEAT-OUT-PRIMO Feature - Configuration



* = Optional HEAT-OUT-PRIMO location

WARNING! Risk of Overheating! Damper **MUST** be installed with crimped side up. Damper will not function properly.

WARNING! Risk of Fire! Verify damper is operational. Overheating will occur if damper does not open and close.

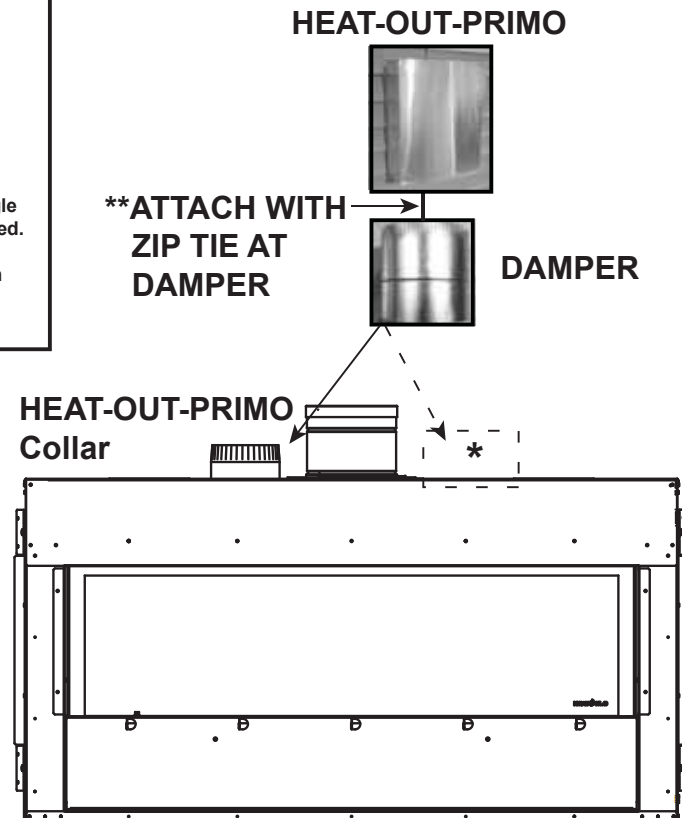
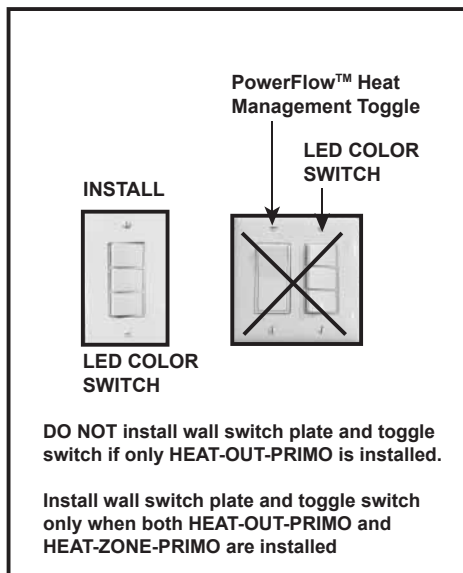

*The HEAT-OUT-PRIMO may be installed in either position shown above.

*Note: Remove only one of the two middle seal plates if installing the HEAT-OUT-PRIMO. The other plate must remain installed.

** Use included zip ties to attach the flex duction to the damper.

Figure 6.16. HEAT-OUT-PRIMO

HEAT-OUT-PRIMO Incorporated with HEAT-ZONE-PRIMO

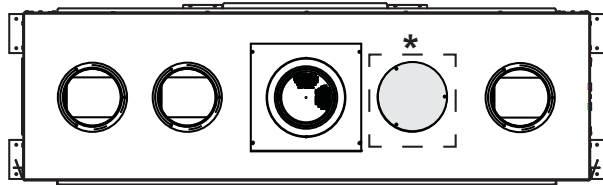

* = Optional HEAT-OUT-PRIMO location

WARNING! Risk of Overheating! Damper **MUST** be installed with crimped side up. Damper will not function properly.

WARNING! Risk of Fire! Verify damper is operational. Overheating will occur if damper does not open and close.

→ For wiring information, see Figure 8.8: HEAT-ZONE-PRIMO incorporated with HEAT-OUT-PRIMO.

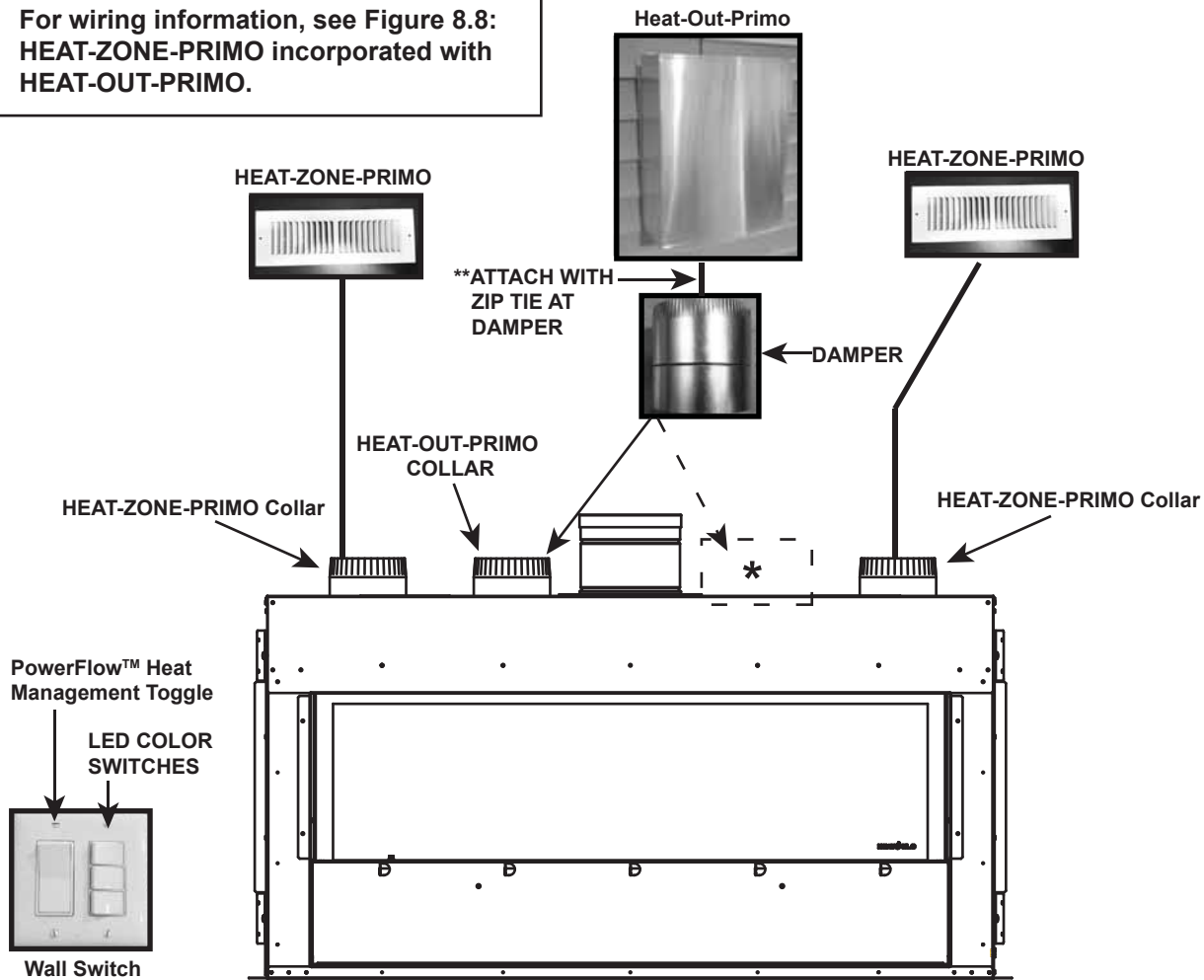

*The HEAT-OUT-PRIMO may be installed in either position shown above.

*Note: Remove only one of the two middle seal plates if installing the HEAT-OUT-PRIMO. The other plate must remain installed.

** Use included zip ties to attach the flex ducting to the damper.

Figure 6.17. HEAT-ZONE-PRIMO and HEAT-OUT-PRIMO Features

E. Burner Glass Installation

Installation

1. Locate packaged burner glass pieces shipped inside the firebox.
2. Position the burner glass tight to the burner tube as shown in Figure 6.18.

Note: The burner glass is designed to fit tightly. The screws located adjacent to the burner glass locations may be loosened in order to allow for more clearance when placing the burner glass into the appliance.

Note: The two small pieces should be located at the right end of the burner tube.

3. Slide both rows of glass tight to the screw heads located in front of the pilot assembly.

NOTICE: Gaps between pieces of glass or between glass and burner tubes will negatively affect flame appearance.

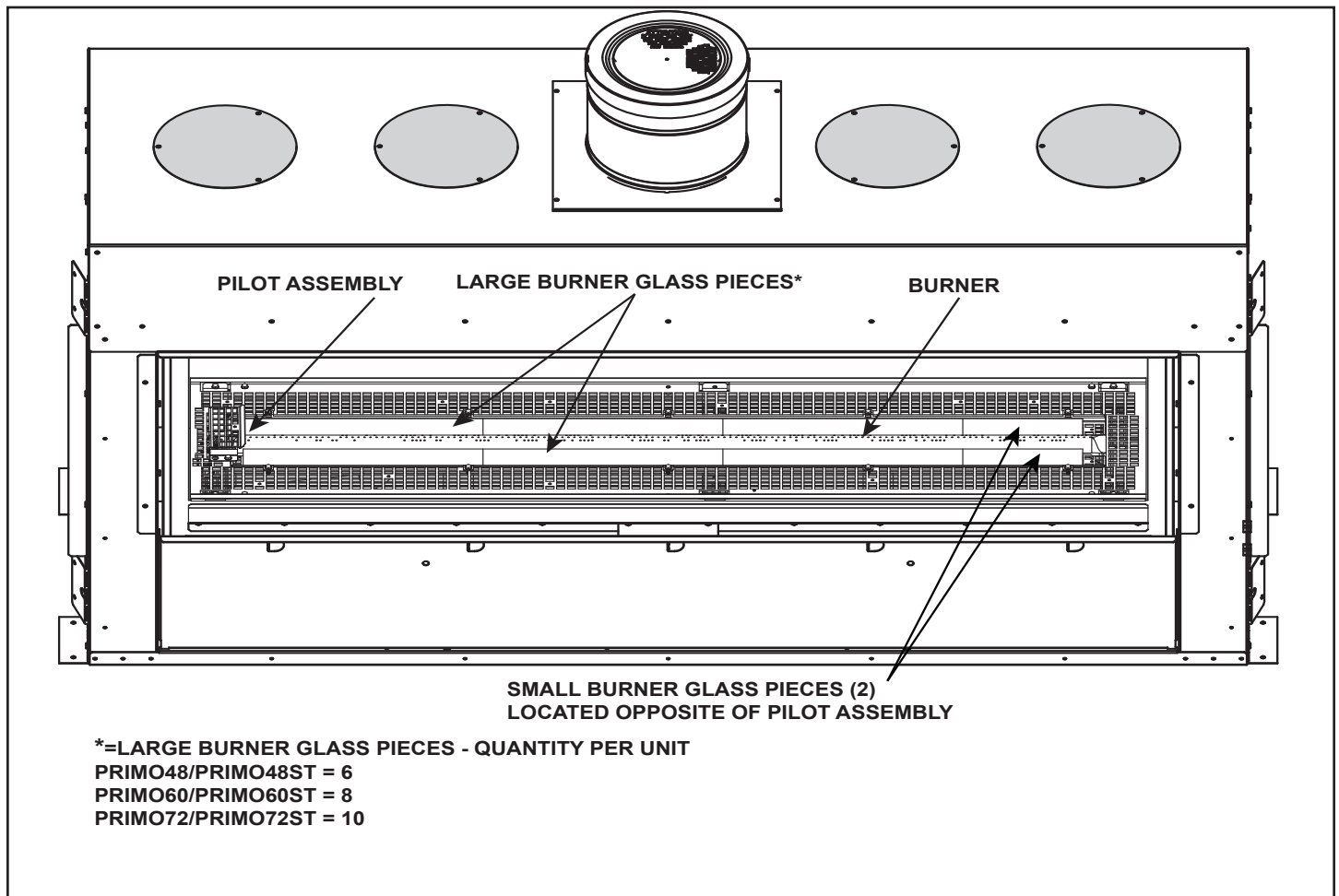

Figure 6.18. Burner Glass Installation

7 Venting and Chimneys

A. Assemble Vent Sections (DVP Only)

Attach Vent to the Firebox Assembly

Note: The end of the pipe sections with the lanced tabs will face toward the appliance.

Attach the first pipe section to the factory-installed 6 inch pipe section:

- Lanced pipe end of the starting collar.
- Inner pipe over inner collar.
- Push the pipe section until all lanced tabs snap in place.
- Lightly tug on pipe to confirm it has locked.
- Slide the gasket over the first vent section and place it flush to the appliance. This will prevent cold air infiltration. Secure with four screws. See Section 6.

All outer pipe joints must be sealed with 100% silicone (300° F minimum continuous exposure rating) or aluminum foil duct tape, including the slip section that connects directly to the horizontal termination cap.

- Apply a bead of silicone sealant (300° F minimum continuous exposure rating) inside the female outer pipe joint prior to joining sections. See Figure 7.1.
- Only outer pipes need to be sealed. All unit collar, pipe, slip section, elbow and cap outer flues shall be sealed in this manner, unless otherwise stated.



Figure 7.1 High Temperature Silicone Sealant

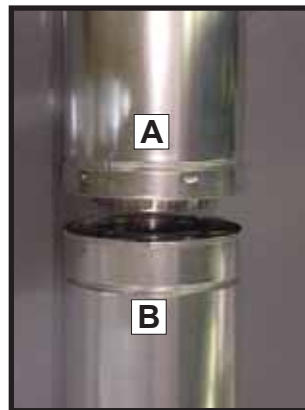

Figure 7.2

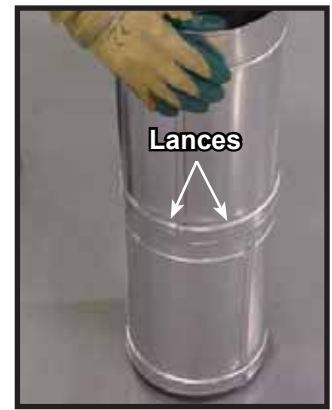

Figure 7.3

WARNING! Risk of Fire or Explosion! DO NOT break silicone seals on slip sections. Use care when removing termination cap from slip pipe. If slip section seals are broken during removal of the termination cap, vent could leak.

Assemble Pipe Sections

Per Figure 7.2:

- Start the inner pipe on the lanced end of section A into the flared end of section B.
- Start the outer pipe of section A over the outer pipe of section B.
- Once both vents sections are started, push firmly until all lanced tabs lock into place.
- Lightly tug on the pipe to confirm the tabs have locked.

It is acceptable to use screws no longer than 1/2 inch (13 mm) to hold outer pipe sections together. If predrilling holes, **DO NOT** penetrate inner pipe.

For 90° and 45° elbows that are changing the vent direction from horizontal to vertical, one screw minimum should be put in the outer flue at the horizontal elbow joint to prevent the elbow from rotating. Use screws no longer than 1/2 inch (13 mm). If predrilling screw holes, **DO NOT** penetrate inner pipe.

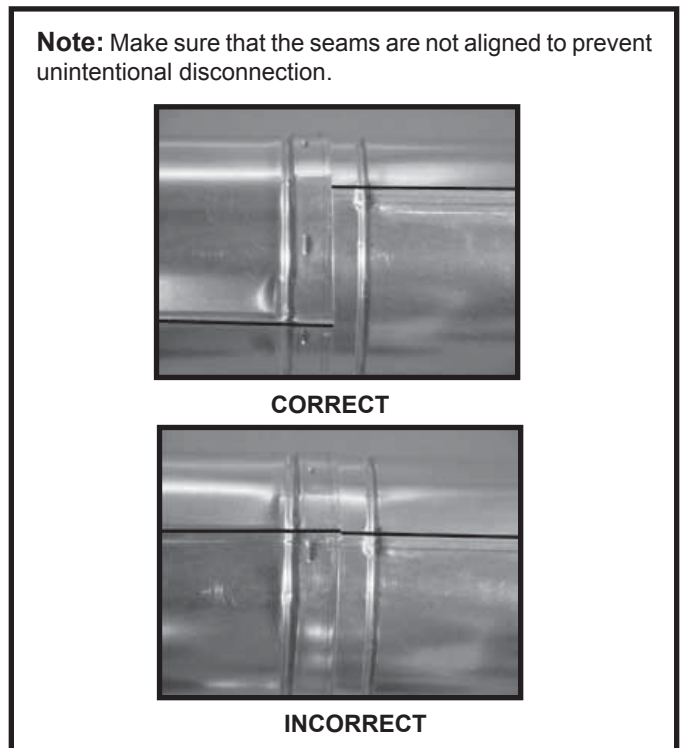

Figure 7.4 Seams

Assemble Vent Sections

(SLP Only)

- Slide the gasket over the first vent section and place it flush to the appliance. This will prevent cold air infiltration. Secure with four screws. See Figure 6.1.
 - Attach the included DVP-2SL adapter to the corresponding DVP pipe section with two screws.
 - Lock the vent components into place by sliding the pipe section onto the collar.
 - Align the seam of the pipe and seam of collar to allow engagement. Rotate the vent component to lock into place. Use this procedure for all vent components. See Figure 7.5.
-
- Continue adding vent components, locking each succeeding component into place.
 - Ensure that each succeeding vent component is securely fitted and locked into the preceding component.

All outer pipe joints must be sealed with high temperature silicone (300° F minimum continuous exposure rating) or aluminum foil duct tape, including the slip section that connects directly to the horizontal termination cap.

- Apply a bead of silicone sealant (300° F minimum continuous exposure rating) inside the female outer pipe joint prior to joining sections. See Figure 7.1.
- Only outer pipes need to be sealed. All unit collar, pipe, slip section, elbow and cap outer flues shall be sealed in this manner, unless otherwise stated.

WARNING! Risk of Fire or Explosion! DO NOT break silicone seals on slip sections. Use care when removing termination cap from slip pipe. If slip section seals are broken during removal of the termination cap, vent could leak.

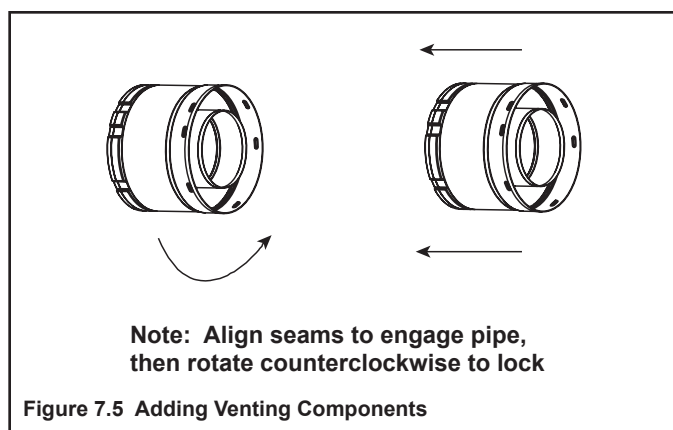

B. Assemble Slip Sections

- Slide the inner flue of the slip section into the inner flue of the pipe section and the outer flue of the slip section over the outer flue of the pipe section. See Figure 7.6.
- Slide together to the desired length.

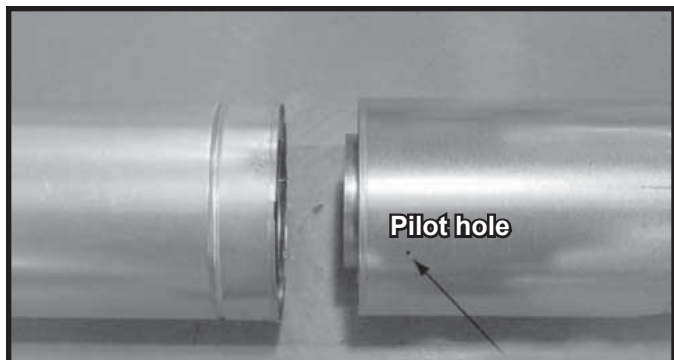

Figure 7.6 Slip Section Pilot Holes

- Maintain a 1-1/2 in. (38 mm) overlap between the slip section and the pipe section.
- Secure the pipe and slip section with two screws no longer than 1/2 in. (13 mm), using the pilot holes in the slip section. See Figure 7.7.

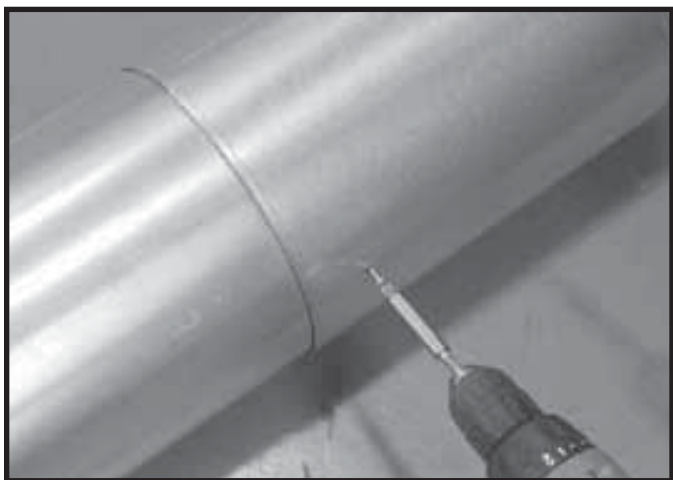

Figure 7.7 Screws into Slip Section

- Continue adding pipe as necessary following instructions in “Assembling Pipe Sections.”

NOTICE: If slip section is too long, the inner and outer flues of the slip section can be cut to the desired length.

NOTICE: When installing a vent system with an HRC termination cap, all pipe system joints shall be sealed using a silicone sealant with a minimum of 300°F continuous exposure rating.

- Apply a bead of silicone sealant inside the female outer pipe joint prior to joining sections.
- Only outer pipes are sealed, sealing the inner flue is not required.
- All unit collar, pipe, slip section, elbow and cap outer flues shall be sealed.

C. Secure the Vent Sections

- Vertical runs originating off the top of the appliance, with no offsets, must be supported every 8 ft. (2.44 m) after the maximum allowed 25 ft. (7.62 m) of unsupported rise.
- Vertical runs originating off the rear of the appliance, or after any elbow, must be supported every 8 ft. (2.44 m).
- Horizontal runs must be supported every 5 feet (1.52 m).
- Vent supports or plumbers strap (spaced 120° apart) may be used to support vent sections. See Figures 7.8 and 7.9.
- Wall shield firestops may be used to provide horizontal support to vent sections.
- SLP ceiling firestops have tabs that may be used to provide vertical support.

WARNING! Risk of Fire, Explosion or Asphyxiation! Improper support could allow vent to sag and separate. Use vent run supports and connect vent sections per installation instructions. **DO NOT** allow vent to sag below connection point to appliance.

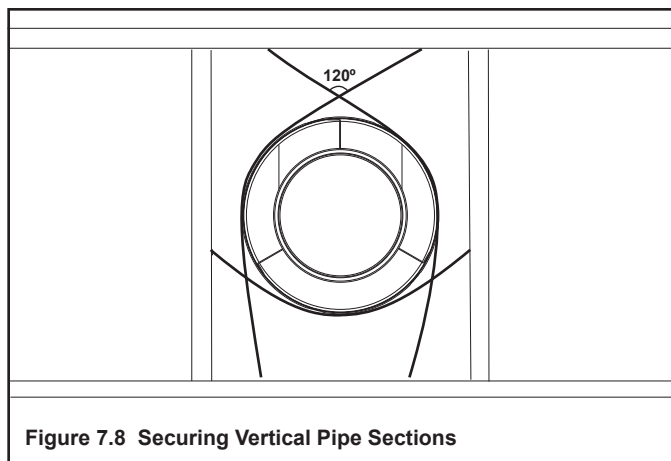

Figure 7.8 Securing Vertical Pipe Sections

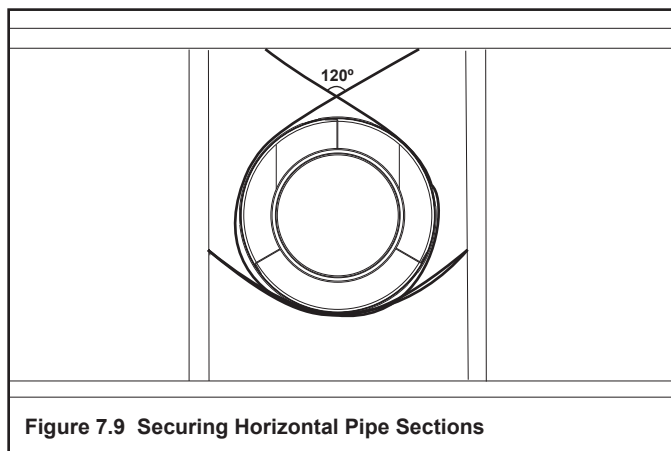

Figure 7.9 Securing Horizontal Pipe Sections

D. Disassemble Vent Sections

- Rotate either section (see Figure 7.10) so the seams on both pipe sections are aligned as shown in Figure 7.11
- Pull carefully to separate the pieces of pipe.

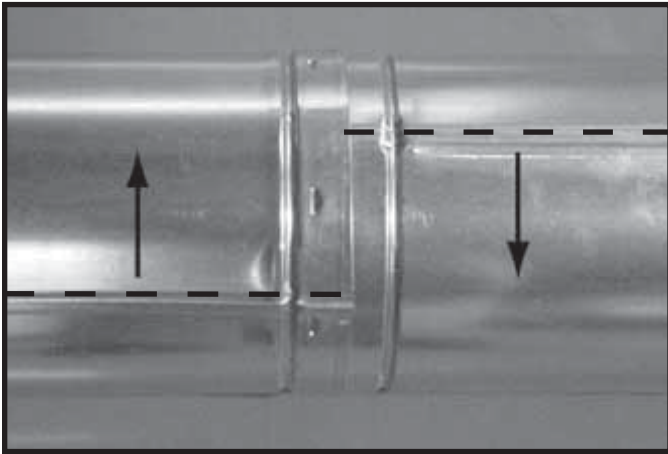

Figure 7.10 Rotate Seams for Disassembly

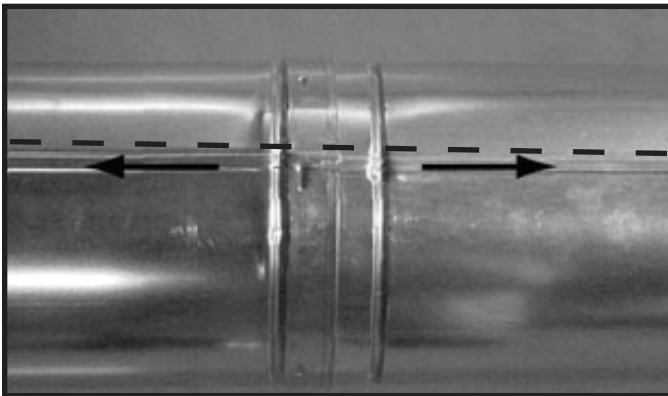
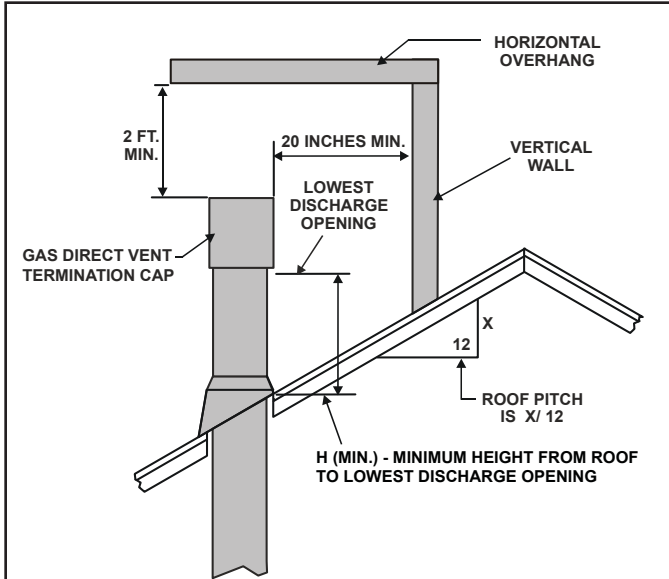

Figure 7.11 Align and Disassemble Vent Sections

E. Vertical Termination Requirements (PVI-SLP)

Install Metal Roof Flashing

- See minimum vent heights for various pitched roofs (Figure 7.12) to determine the length of pipe to extend through the roof.
- Slide the roof flashing over the pipe sections extending through the roof as shown in Figure 7.13.



<u>Roof Pitch</u>	<u>H (Min.) Ft.</u>
Flat to 6/12.....	1.0*
Over 6/12 to 7/12.....	1.25*
Over 7/12 to 8/12.....	1.5*
Over 8/12 to 9/12.....	2.0*
Over 9/12 to 10/12.....	2.5*
Over 10/12 to 11/12.....	3.25
Over 11/12 to 12/12.....	4.0
Over 12/12 to 14/12.....	5.0
Over 14/12 to 16/12.....	6.0
Over 16/12 to 18/12.....	7.0
Over 18/12 to 20/12.....	7.5
Over 20/12 to 21/12.....	8.0

* 3 foot minimum in snow regions

Figure 7.12 Minimum Height From Roof To Lowest Discharge Opening

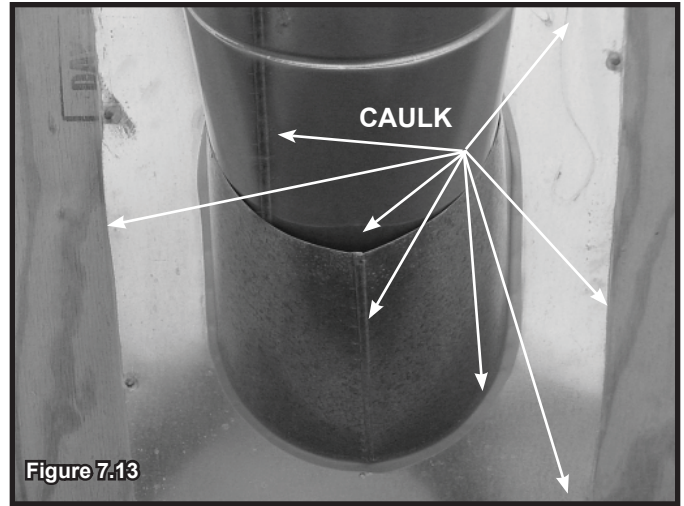

Assemble and Install Storm Collar

CAUTION! Risk of Cuts, Abrasions or Flying Debris. Wear protective gloves and safety glasses during installation. Sheet metal edges are sharp.

- Slide the storm collar onto the exposed pipe section and align brackets.
- Insert a bolt (provided) through the brackets and install nut. Do not completely tighten.



- Slide the assembled storm collar down the pipe section until it rests on the roof flashing (see Figure 7.15).
- Tighten nut and make sure the collar is tight against the pipe section.
- Caulk around the top of the storm collar. See Figure 7.15.

NOTICE: Failure to properly caulk the roof flashing and pipe seams could permit entry of water.

- Caulk the gap between the roof flashing and the outside diameter of the pipe.
- Caulk the perimeter of the flashing where it contacts the roof surface. See Figure 7.13.
- Caulk the overlap seam of any exposed pipe sections that are located above the roof line.

Install Vertical Termination Cap (DVP and SLP Pipe, PVI-SLP)

- Attach the vertical termination cap by sliding the inner collar of the cap into the inner flue of the pipe section while placing the outer collar of the cap over the outer flue of the pipe section.
- Secure the cap by driving three self-tapping screws (supplied) through the pilot holes in the outer collar of the cap into the outer flue of the pipe. See Figure 7.15.



Figure 7.15

F. Horizontal Termination Requirements Heat Shield Requirements for Horizontal Termination (PVI-SLP)

WARNING! Risk of Fire! To prevent overheating and fire, heat shields must extend through the entire wall thickness.

- **DO NOT** remove the heat shields attached to the wall shield firestop and the horizontal termination cap (shown in Figure 7.16).
- Heat shields must overlap 1-1/2 in. (38 mm) minimum.

There are two sections of the heat shield. One section is factory-attached to the wall shield firestop. The other section is factory-attached to the cap. See Figure 7.16.

If the wall thickness does not allow the required 1-1/2 in. (38 mm) heat shield overlap when installed, an extended heat shield must be used.

- If the wall thickness is less than 4 in./102 mm (DVP) or 4-3/8 in./ 111 mm (SLP), the heat shields on the cap and wall shield firestop must be trimmed. A minimum 1-1/2 in. (38 mm) overlap **MUST** be maintained.
- Use an extended heat shield if the finished wall thickness is greater than 7-1/4 in. (184 mm).
- The extended heat shield may need to be cut to length maintaining sufficient length for a 1-1/2 in. (38 mm) overlap between heat shields.
- Attach the extended heat shield to either of the existing heat shields using the screws supplied with the extended heat shield. Refer to vent components diagrams in the back of this manual.
- Rest the small leg on the extended heat shield on top of the pipe section to properly space it from the pipe section.

Important Notice: Heat shields may not be field constructed.

Install Horizontal Termination Cap (PVI-SLP)

WARNING! Risk of Fire! The telescoping flue section of the termination cap **MUST** be used when connecting vent.

- 1-1/2 (38 mm) minimum overlap of flue telescoping section is required.

Failure to maintain overlap could cause overheating and fire.

- Vent termination must not be recessed in the wall. Siding may be brought to the edge of the cap base.
- Flash and seal as appropriate for siding material at outside edges of cap.
- When installing a horizontal termination cap, follow the cap location guidelines as prescribed by current **ANSI Z223.1** and **CAN/CGA-B149** installation codes and refer to Section 6 of this manual.

CAUTION! Risk of Burns! Local codes may require installation of a cap shield to prevent anything or anyone from touching the hot cap.

NOTICE: For certain exposures which require superior resistance to wind-driven rain penetration, a flashing kit and HRC caps are available. When penetrating a brick wall, a brick extension kit is available for framing the brick.

Note: When using termination caps with factory-supplied heat shield attached, no additional wall shield firestop is required on the exterior side of a combustible wall.

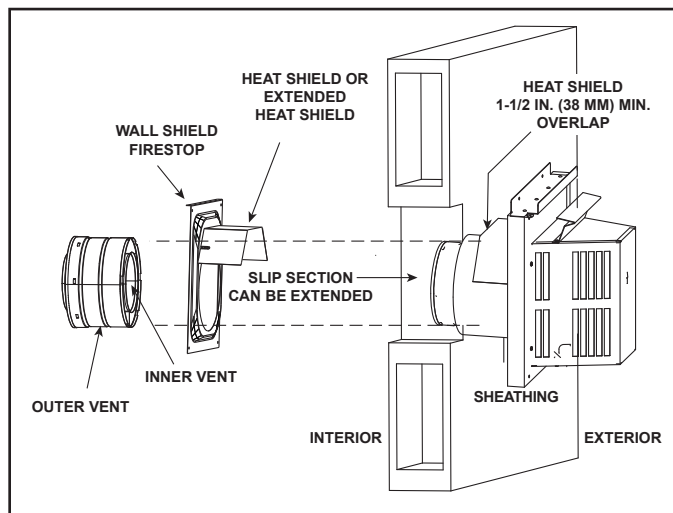

Figure 7.16 Venting Through the Wall - PVI-SLP

- Flash and seal as appropriate for siding material at outside edges of cap.

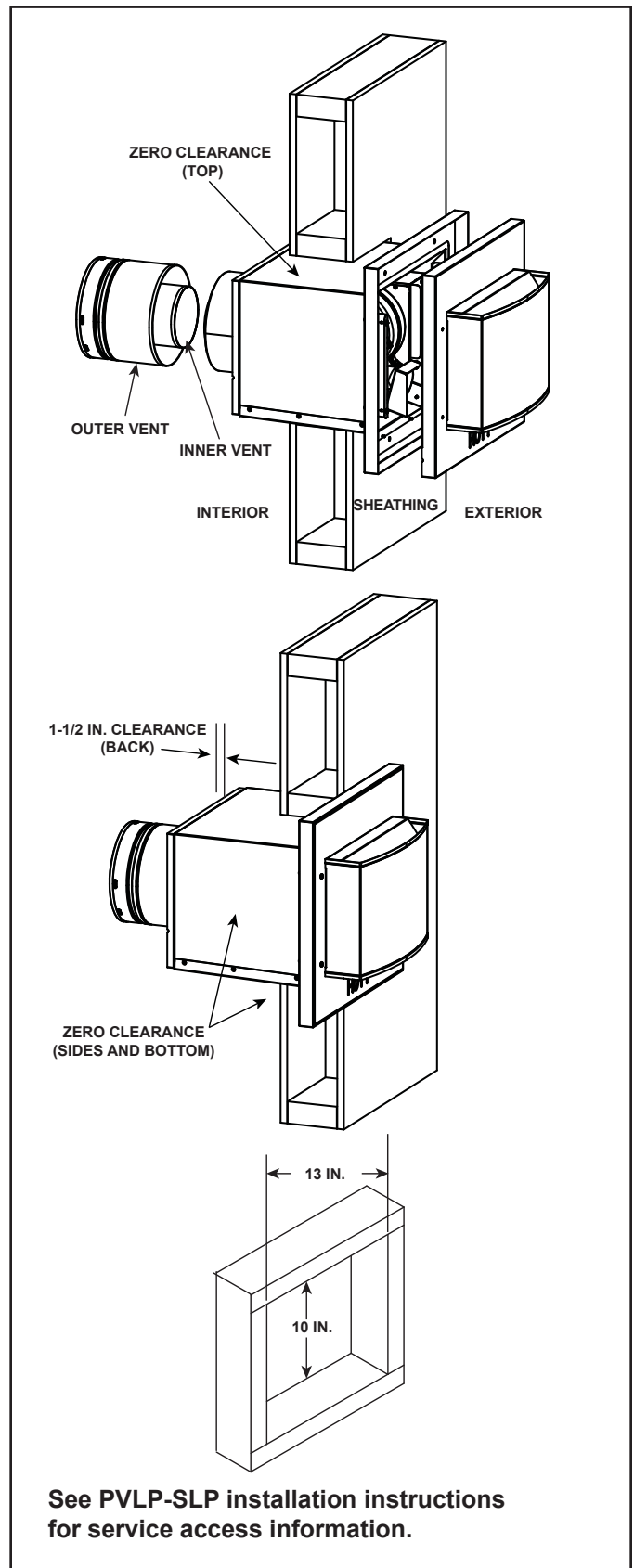

Figure 7.17 Venting Through the Wall - PVLPSLP

Install PVLPSLP Horizontal Termination Cap

WARNING! Risk of Fire! The telescoping flue section of the termination cap **MUST** be used when connecting vent.

- 1-1/2 (38 mm) minimum overlap of flue telescoping section is required.

Failure to maintain overlap could cause overheating and fire.

- Vent termination must not be recessed in the wall. Siding may be brought to the edge of the cap base.

8 Electrical Information

A. General Information

WARNING! Risk of Shock or Explosion! DO NOT wire 110-120 VAC to the valve or to the appliance wall switch. Incorrect wiring will damage controls.

NOTICE: This appliance must be electrically wired and grounded in accordance with local codes or, in the absence of local codes, with **National Electric Code ANSI/NFPA 70-latest edition or the Canadian Electric Code CSA C22.1.**

- Wire the appliance junction box to unswitched 110-120 VAC. This is required for proper operation of the appliance.
- A 110-120 VAC circuit for this product must be protected with ground-fault circuit-interrupter protection, in compliance with the applicable electrical codes, when it is installed in locations such as in bathrooms or near sinks.
- Low voltage and 110/120 VAC voltage cannot be shared within the same wall box.
- See Figures 8.1, 9.7 and 9.8 for routing electrical power from the appliance to the power vent (PVI-SLP or PVLPSLP), wall switch and PowerFlow™ Heat Management System.

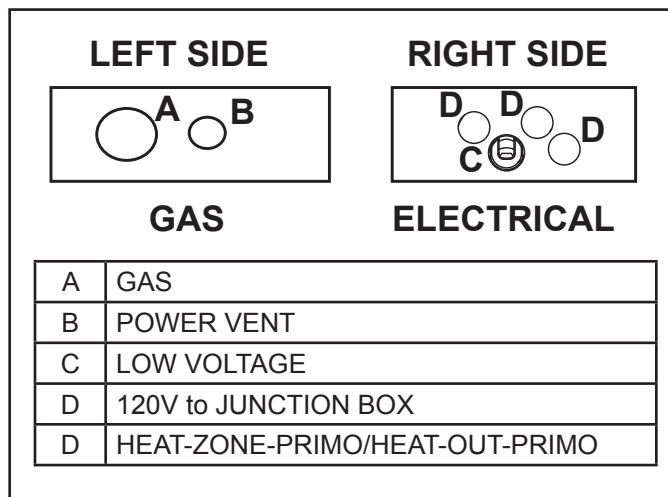

Figure 8.1 Access Plates

Electrical Service and Repair

WARNING! Risk of Shock! Label all wires prior to disconnection when servicing controls. Wiring errors can cause improper and dangerous operation. Verify proper operation after servicing.

WARNING! Risk of Shock! Replace damaged wire with type 105° C rated wire. Wire must have high temperature insulation.

Accessories Requirements

- This appliance must be used with the supplied wall switch and remote control.

Wiring for optional Hearth & Home Technologies approved accessories should be done now to avoid reconstruction. Follow instructions that come with those accessories.

- The PRIMO model requires electrical power in order to operate the required PowerFlow™ Heat Management System and power vent. If electrical power service is interrupted during operation of this model, the appliance will not operate. **Battery power is not an option on the PRIMO.**

Reset Switch

- Press the RESET switch located on the left side of the transition media tray. Use a small, flat object to access the switch. When the appliance has started, flip the reset switch back to its original position. See Figure 8.2.

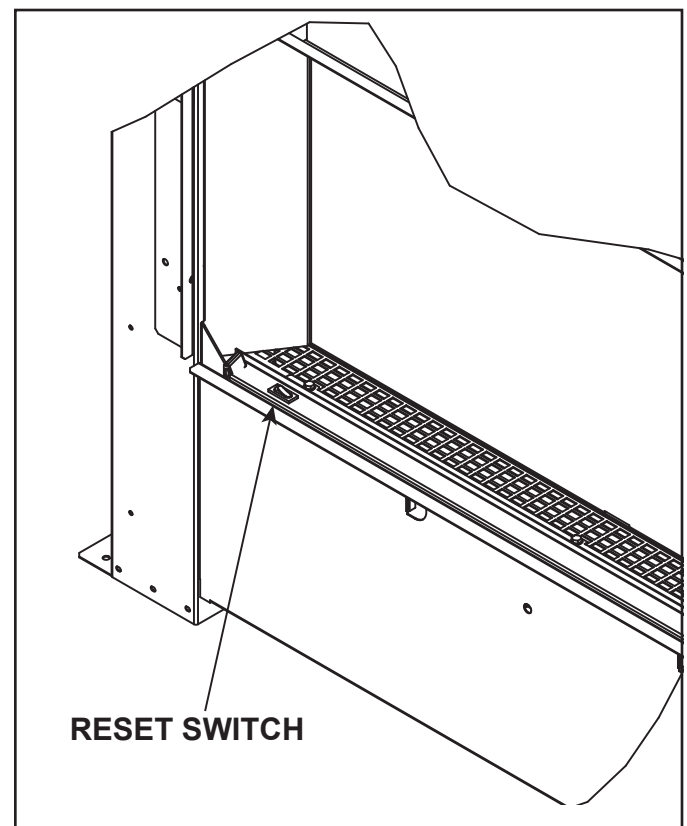

Figure 8.2 Reset Switch Location - Bottom Left

Junction Box Wiring

WARNING! Risk of Shock! Label all wires prior to disconnection when servicing controls. Wiring errors can cause improper and dangerous operation. Verify proper operation after servicing.

WARNING! Risk of Shock! Replace damaged wire with type 105° C rated wire. Wire must have high temperature insulation.

IMPORTANT NOTE: The lower access cover panel is removable if finishing materials are not installed. See Figure 8.5. If finishing materials are installed, lift the transition media tray out of glass frame bracket to access valve cavity.

CAUTION! Risk of Cuts! Wear protective gloves and safety glasses during installation. Use suction cups to handle safety barrier glass.

In the event that the junction box may need to be accessed or installed after finish methods have been applied, access is possible by removing the barrier glass and transition media tray. See Section 10 for details.

1. Remove the one screw that secures the junction box to the control tray panel. See Figure 8.3.
2. Route the wire through the access plate using a strain relief and down through the wire slot located behind the junction box. See Figure 8.1 and 8.3.

3. Make the connection inside the junction box to the 110-120VAC wire. Connect green to the ground nut, black to black, and white to white.
4. To reattach the junction box, insert one end of the junction box in the slot provided and securely screw the other end of the junction box to the control tray panel.

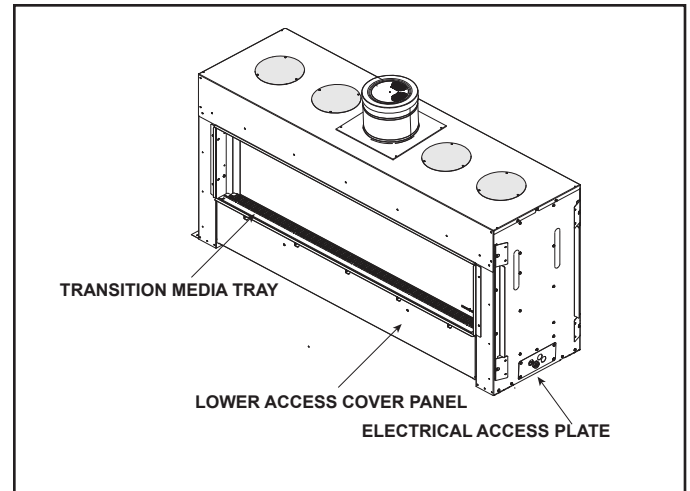

Figure 8.5. Junction Box/Control Service Access

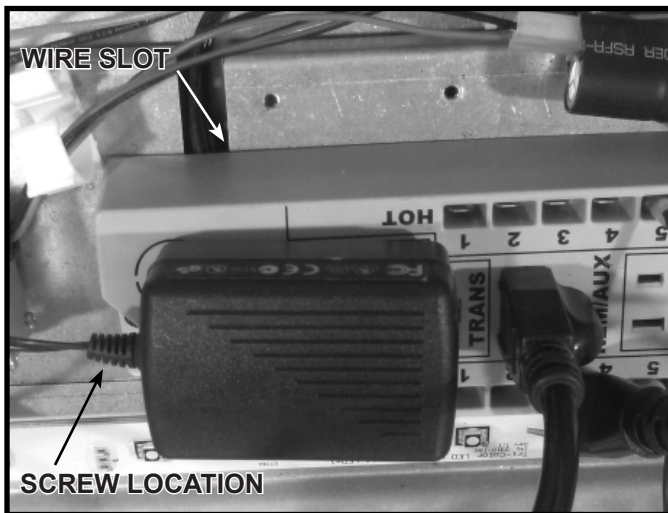

Figure 8.3 Junction Box Detail



Figure 8.4. Valve Cavity (Lower Access Cover Panel Removed)

LED Lighting

WARNING! Risk of Shock! Label all wires prior to disconnection when servicing controls. Wiring errors can cause improper and dangerous operation. Verify proper operation after servicing.

WARNING! Risk of Shock! Replace damaged wire with type 105° C rated wire. Wire must have high temperature insulation.

The functions and colors for the LED lighting on the PRIMO appliance are controlled by the included wall switch.

LED Switch Wiring

Wire the LED switch with the included low voltage wire. Be sure to install the switch and wiring according to the orientation shown in Figure 8.6.

LED Switch Operation

Three white toggle switches are used to operate the interior lighting for the fireplace. There are seven color options. See Figure 8.6. Flipping a combination of these three buttons activates the desired color. The chart in Figure 8.6 shows the combinations for each of the seven colors.

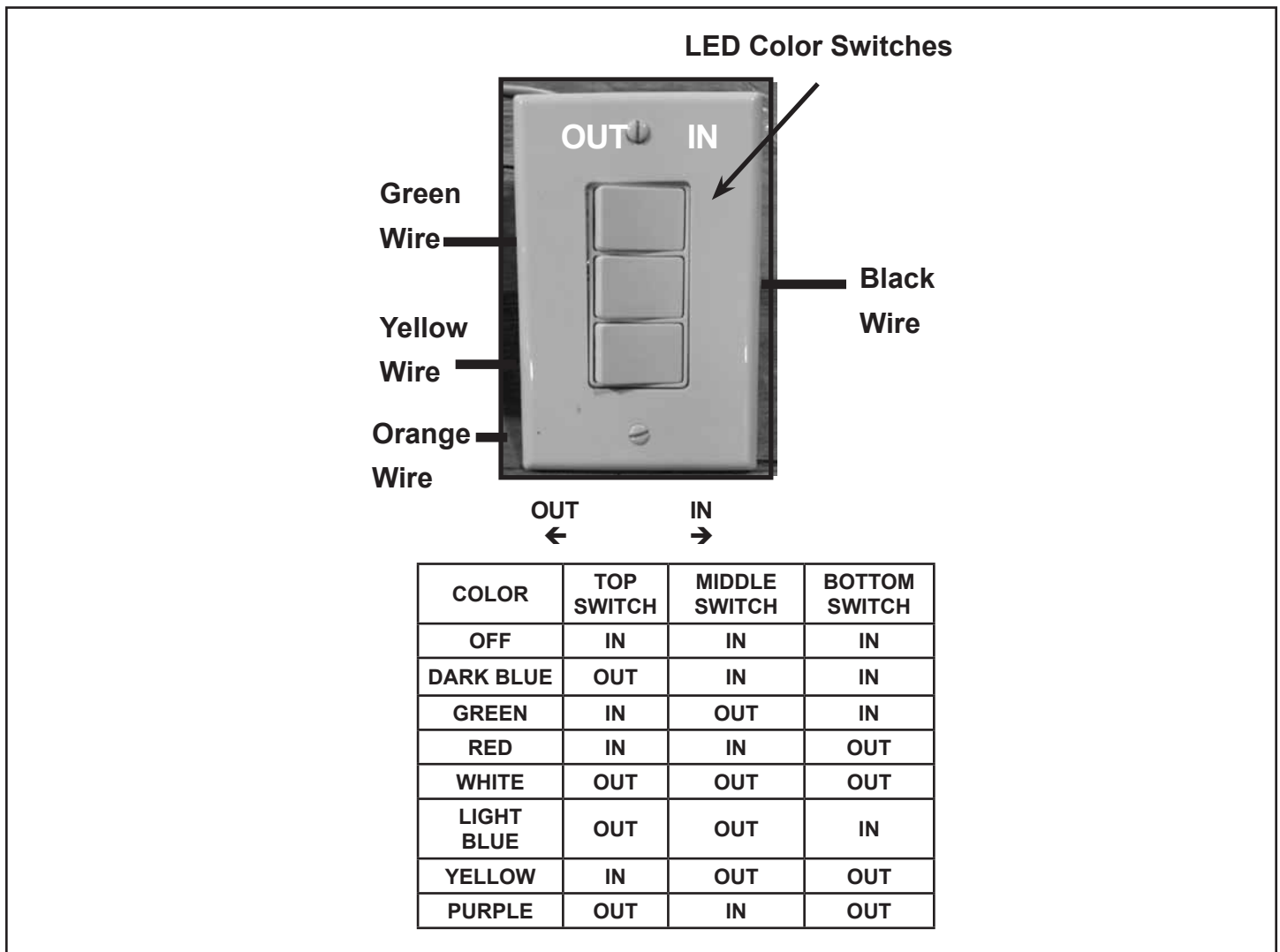

Figure 8.6. LED Switch Operation

B. Wiring Requirements

IntelliFire™ Plus Ignition System Wiring

- Wire the appliance junction box to 110-120 VAC for proper operation of the appliance.

WARNING! Risk of Shock or Explosion! DO NOT wire IPI controlled appliance junction box to a switched circuit. Incorrect wiring will override IPI safety lockout.

- Refer to Figure 8.7, IPI Wiring Diagram.
- This appliance is equipped with an IntelliFire™ Plus control valve which operates on a 6 volt/1.5 AMP system.
- Plug the 6 volt transformer plug into the appliance junction box to supply power to the appliance.

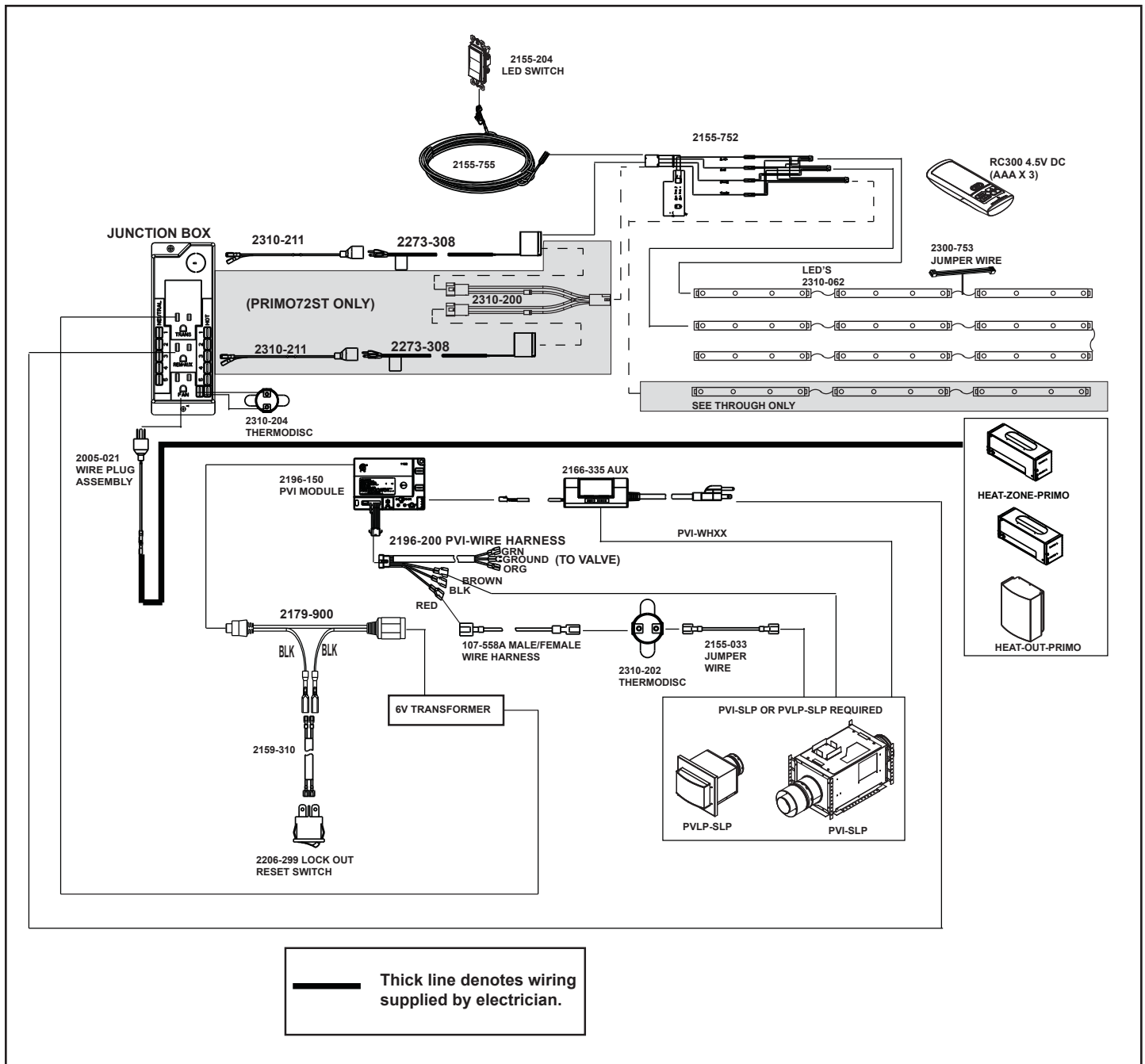

→ Figure 8.7 PRIMO Wiring Diagram

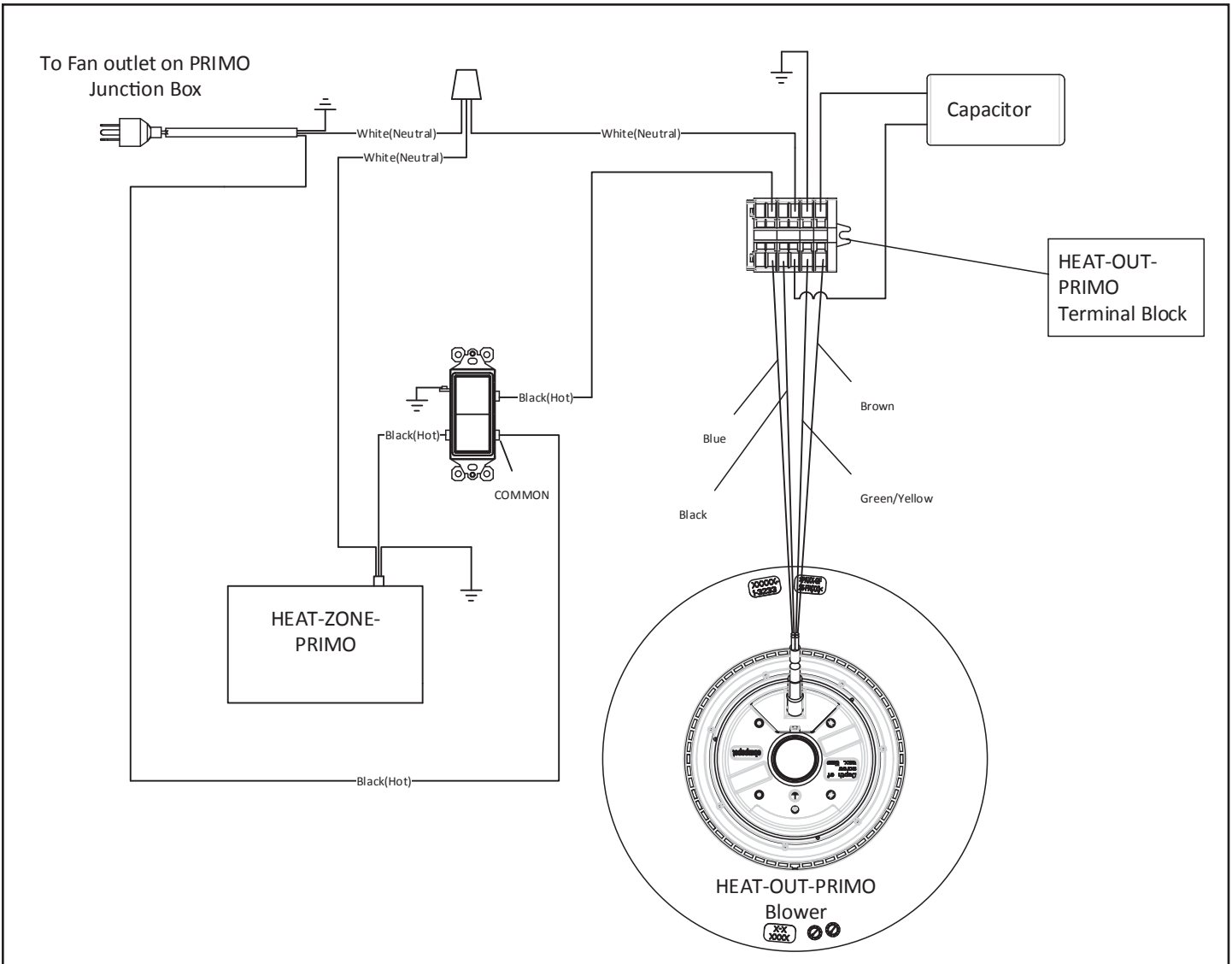

→ Figure 8.8 HEAT-ZONE-PRIMO Incorporated with HEAT-OUT-PRIMO

9 Gas Information

A. Fuel Conversion

- Make sure the appliance is compatible with available gas types.
- Conversions must be made by a qualified service technician using Hearth & Home Technologies specified and approved parts.

B. Gas Pressure

- Optimum appliance performance requires proper input pressures.
- Gas line sizing requirements will be determined in ANSI Z223.1 National Fuel Gas Code in the USA and CAN/CGA B149 in Canada.
- Pressure requirements are:

Gas Pressure	Natural Gas	Propane
Minimum inlet pressure	5.0 in. w.c.	11.0 in. w.c.
Maximum inlet pressure	10.0 in. w.c.	13.0 in. w.c.
Manifold pressure	3.5 in. w.c.	10.0 in. w.c.

WARNING! Risk of Fire or Explosion! High pressure will damage valve. Low pressure could cause explosion.

- Verify inlet pressures. Verify minimum pressures when other household gas appliances are operating.
- Install regulator upstream of valve if line pressure is greater than 1/2 psig.
- Valve pressure taps are accessible by removing the lower access cover panel. See Figure 9.1 and 9.2. If the appliance has been fully installed and finished, remove the barrier glass and transition media tray.

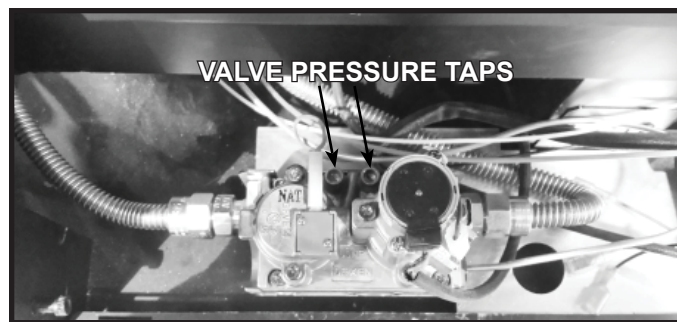



Figure 9.1. Valve Pressure Taps.

⚠ WARNING	
 	<p>Fire Risk. Explosion Hazard. High pressure will damage valve.</p> <ul style="list-style-type: none"> • Disconnect gas supply piping BEFORE pressure testing gas line at test pressures above 1/2 psig. • Close the manual shutoff valve BEFORE pressure testing gas line at test pressures equal to or less than 1/2 psig.

Note: Have the gas supply line installed in accordance with local codes, if any. If not, follow ANSI 223.1. Installation should be done by a qualified installer approved and/or licensed as required by the locality. (In the Commonwealth of Massachusetts installation must be performed by a licensed plumber or gas fitter).

Note: A listed (and Commonwealth of Massachusetts approved) 1/2 in. (13 mm) T-handle manual shut-off valve and flexible gas connector are connected to the 1/2 in. (13 mm) control valve inlet.

- **If substituting for these components, please consult local codes for compliance.**

C. Gas Service Access

IMPORTANT NOTE: The lower access cover panel is removable if finishing materials are not installed. See Figure 9.2. If finishing materials are installed, lift the transition media tray out of glass frame bracket to access valve cavity.

CAUTION! Risk of Cuts! Wear protective gloves and safety glasses during installation. Use suction cups to handle safety barrier glass.

Note: If a granite surround is installed, the two side sections need to be removed in order to access the gas train. See Section 10.C.

1. Remove the safety barrier glass with two suction cups. Lift the glass up and out of the opening. See Section 11 for instructions.
2. Remove side glass or granite transition panels and remove the granite and/or glass transition brackets located on the left and right sides of the appliance opening. See Section 10 for details.

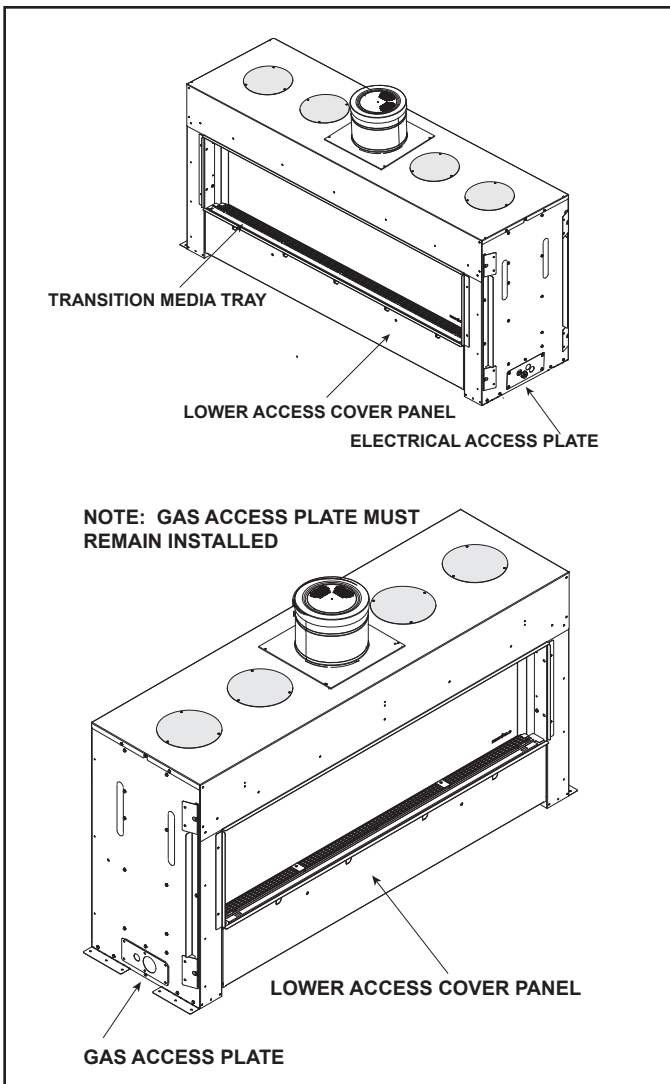

Figure 9.2. Gas Service Access

3. Remove the transition media from the appliance. Lift the transition media tray out of appliance. Disconnect the reset switch. The transition media tray fits tightly, lift carefully.
4. Loosen two shoulder bolts from the transition LED tray assembly located below the appliance opening. Carefully remove the transition LED tray assembly.

NOTICE: LED wires are installed. Handle transition LED tray assembly with care.

5. Turn off power to the module and valve by unplugging the 6V transformer from the junction box.
6. Turn off gas valve. The red shutoff knob is located on the supply line. Turn ball valve off.

If additional access is needed, proceed as follows:

7. Remove firebox glass from appliance by unlatching the top spring latches from the glass frame and lifting glass frame assembly out of the bottom bracket. See Section 11.
8. Remove interior media, logs, and panels from the unit if already installed.
9. Remove the burner glass. See Figure 9.3.
10. Remove the media tray. It is attached to the interior firebox bottom with screws. See Figure 9.3.
11. Remove the two screws that attach the pilot to the burner leg.
12. Remove the six screws securing the burner to the firebox sides and disengage burner from orifice. Remove burner. See Figure 9.4.
13. Remove the screws that secure the glass window. Remove the glass window. Handle with care. See Figure 9.5.
14. Carefully remove LED tray assembly from appliance by lifting up and out through the bottom glass opening.

NOTICE: LED wires are installed. Handle transition LED tray assembly with care.

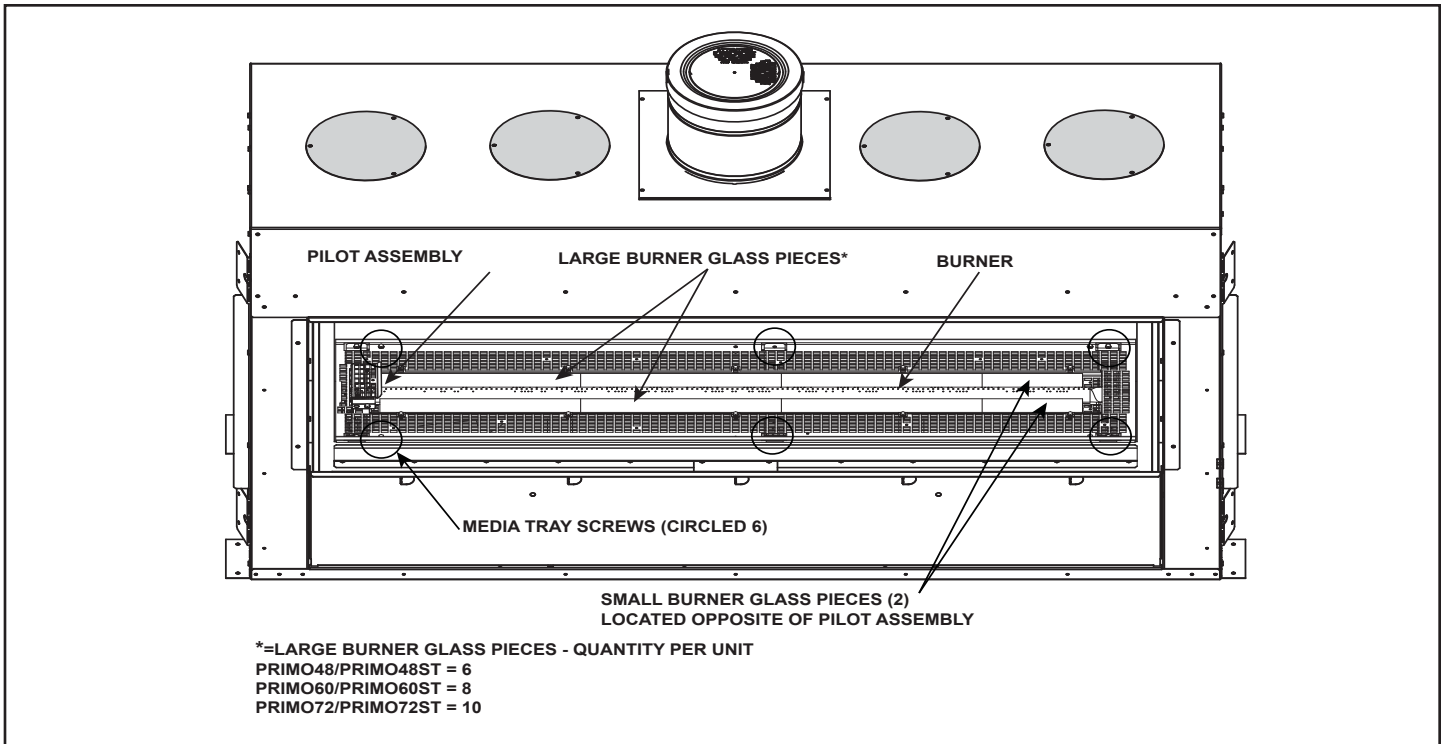

Figure 9.3. Base Pan with Burner, Pilot Cover and Burner Glass

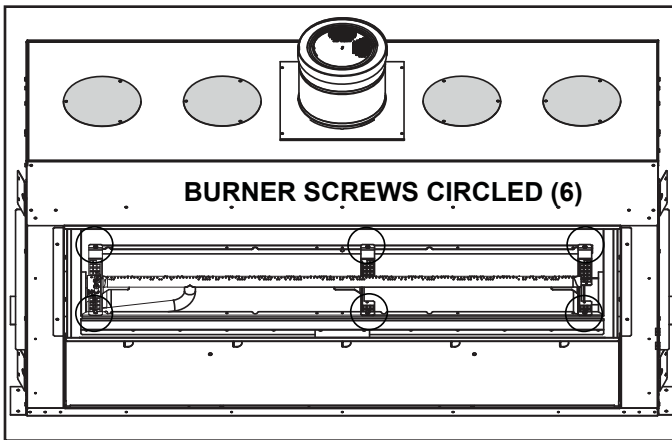

Figure 9.4 Location of Burner Screws

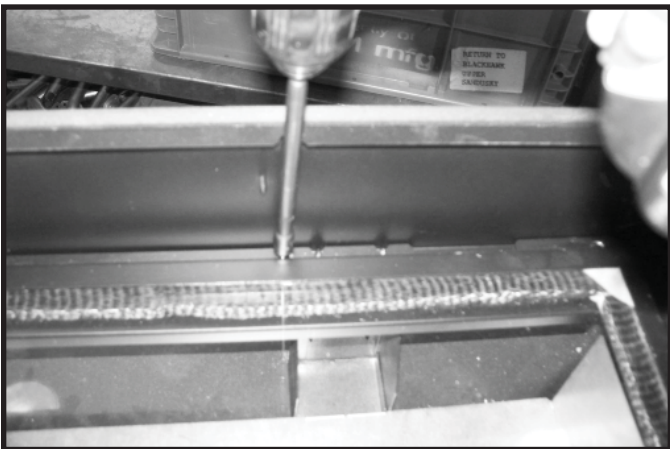

Figure 9.5 Additional Gas and Electrical Access

D. Gas Connection

- Refer to Figure 9.7 for location of gas line access in appliance.
- Gas line must be run through the left side of appliance.
- The gap between supply piping and gas access hole may be caulked with caulk with a minimum of 300°F continuous exposure rating or stuffed with non-combustible, unfaced insulation to prevent cold air infiltration.
- Gas access plate must remain installed or barrier glass will become hot.

CAUTION! Risk of Burns! Do NOT remove gas access plate.

- Hot barrier glass could cause burns.
- Appliance will overheat.

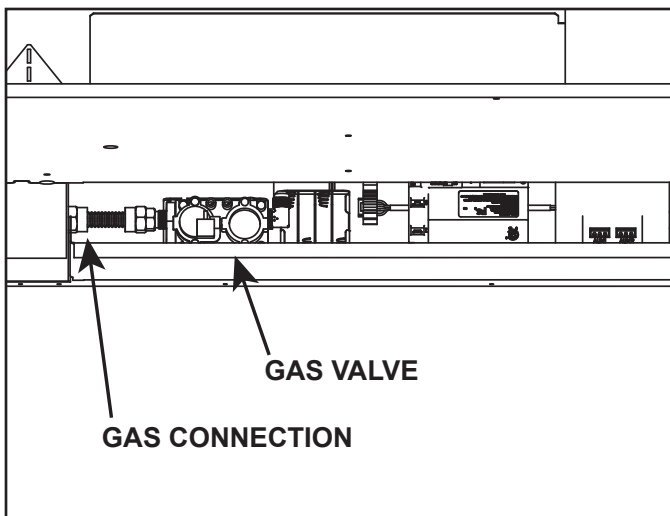

Figure 9.6 Gas Fitting Access- Lower Left Side

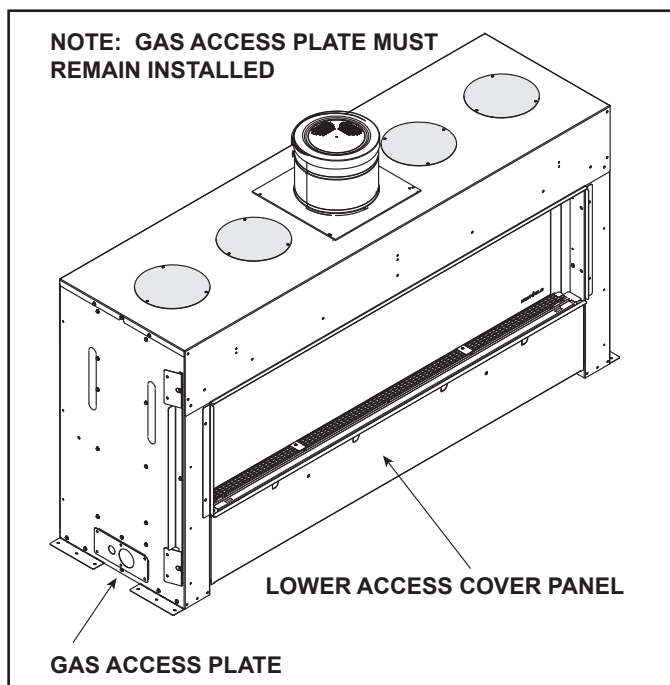

Figure 9.7 Gas Access Location - Left Side

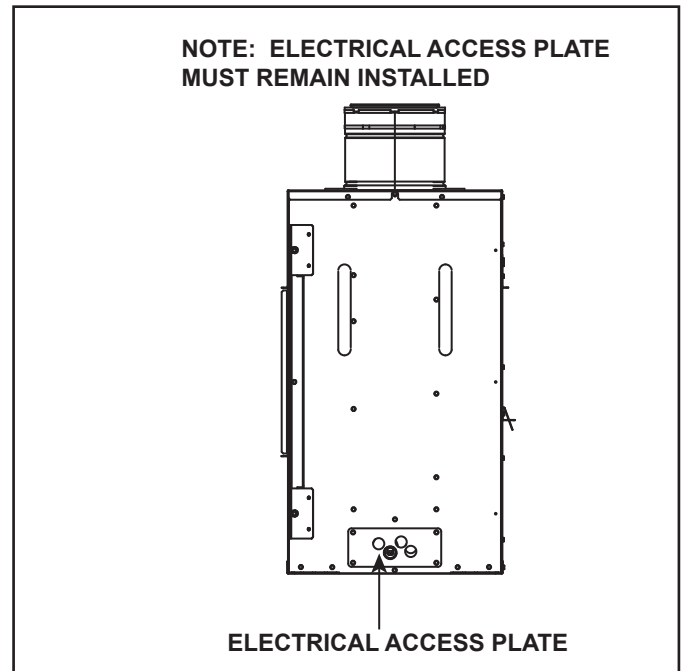

Figure 9.8 Electrical Access Location - Right Side

- Ensure that gas line does not come in contact with outer wrap of the appliance. Follow local codes.
- Pipe incoming gas line into valve compartment.
- Connect incoming gas line to the 1/2 in. (13 mm) connection on manual shutoff valve.

WARNING! Risk of Fire or Explosion! Support control when attaching pipe to prevent bending gas line.

- A small amount of air will be in the gas supply lines.

WARNING! Risk of Fire or Explosion! Gas build-up during line purge could ignite.

- Purge should be performed by qualified service technician.
- Ensure adequate ventilation.
- Ensure there are no ignition sources such as sparks or open flames.

Turn the appliance on. The appliance is equipped with a pre-purge safety feature. After the pre-purge, the appliance will take approximately 2 to 3 minutes to light. It will take a short time for air to purge from lines. When purging is complete the appliance will light and operate normally.

WARNING! Risk of Fire, Explosion or Asphyxiation! Check all fittings and connections with a non-corrosive commercially available leak-check solution. **DO NOT** use open flame. Fittings and connections could have loosened during shipping and handling.

WARNING! Risk of Fire! **DO NOT** change valve settings. This valve has been preset at the factory.

E. High Altitude Installations

NOTICE: If the heating value of the gas has been reduced, these rules do not apply. Check with your local gas utility or authorities having jurisdiction.

When installing above 2000 feet elevation:

- In the USA: Reduce burner orifice 4% for each 1000 feet above 2000 feet.
- In CANADA: Reduce burner orifice 10% for elevations between 2000 feet and 4500 feet. Above 4500 feet, consult local gas utility.

F. Air Shutter Setting

Air shutter settings may be adjusted by a qualified installer at the time of installation. The air shutter is set at the factory for optimal flame appearance. The factory air shutter setting is recommended for all vent runs. See Figure 9.9.

- Refer to Gas Service Access instructions in Section 9.C to access the air shutter.
- Loosen the 1/4 in. screw.
- Twist shutter to adjust.
- The factory setting is recommended for all vent runs.
- Do not close the air shutter more than 1/16 in. for NG or 3/8 in. for propane.
- Tighten the screw.

NOTICE: If sooting occurs, provide more air by opening the air shutter.

Air Shutter Settings

	NG	Propane
PRIMO48 PRIMO48ST	1/16 in.	3/8 in.
PRIMO60 PRIMO60ST	1/8 in.	Full Open
PRIMO72 PRIMO72ST	1/8 in.	N/A

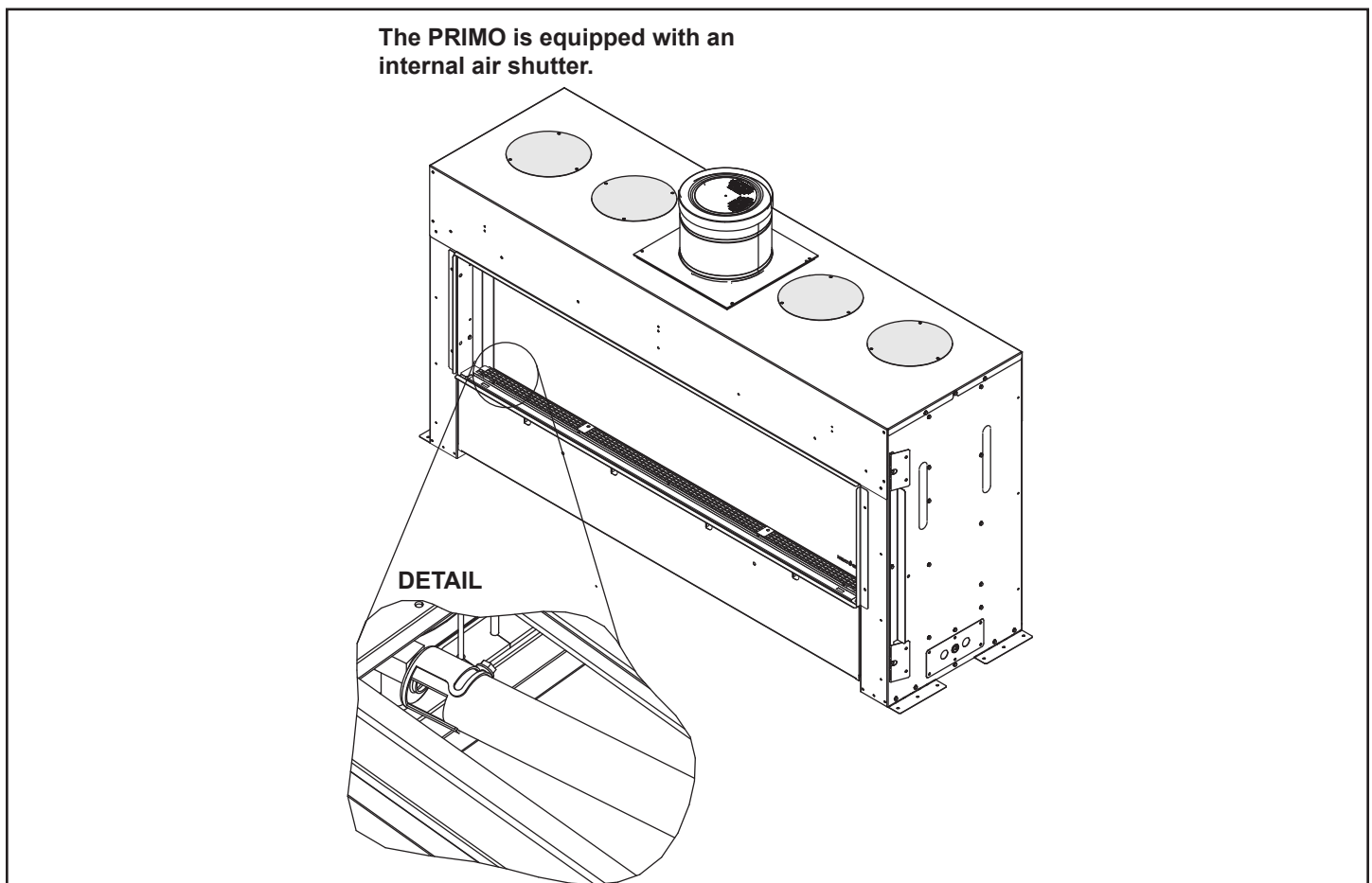

Figure 9.9 Air Shutter Location

10 Finishing

A. Facing and Finishing - General Information

WARNING! Risk of Fire! *Comply with all minimum clearances to combustibles as specified. Framing closer than the minimums listed must be constructed entirely of noncombustible materials (i.e., steel studs, concrete board, etc.).*

Splatter Guard

The splatter guard is a piece of corrugated material used to protect the appliance during the installation process before finishing work on the whole hearth is complete. A splatter guard is factory-installed on PRIMO models. Splatter guards must be removed before appliance is fired.

WARNING! Risk of Fire! *Remove the splatter guard before lighting the appliance. Shut off gas to the appliance when the splatter guard is in place to prevent accidental operation.*

Finishing Instructions

It is important to follow the framing and finishing instructions to ensure proper placement of fireplace into the surrounding framing/finishing materials.

Wall sheathing materials 1/2 in. thick are specified in this installation manual to properly align with the optional finishing methods offered with this appliance. The PRIMO may be finished to the appliance opening with 1/2 inch thick sheetrock.

- Ensure that the one inch back clearance and one inch side clearances are maintained.

WARNING! Risk of Fire! *Maintain specified air space clearances to combustibles. Inadequate air space could cause overheating and fire.*

WARNING! Risk of Fire, Explosion or Asphyxiation! **DO NOT** use screws more than 3/4 inch long on lower access cover panel. Longer screws may penetrate gas line or damage valve or electrical components.

The appliance is designed to be used with 1/2 in. wall sheathing materials such as drywall, plywood, wood composites, or non-combustible materials.

Note: It is acceptable to use a high temperature silicone sealant to adhere drywall to lower access cover panel.

Finish and Sealing Joints

All joints between the finished wall sheathing and the appliance must be sealed with non-combustible materials. Sealants, such as caulk or mastic used to seal the gap between the wall and the fireplace, should be rated at a minimum continuous exposure to 300°F.

Facing Material

- Facing and/or finishing materials must never overhang into the glass opening. See Figure 10.2.
- Facing materials may be combustible or non-combustible.

WARNING! Risk of Fire! DO NOT apply combustible materials beyond the minimum clearances. Comply with all minimum clearances to combustibles as specified in this manual. Overlapping materials could ignite and will interfere with proper operation.

Painting

If desired finishing includes a painted wall, 100% acrylic latex, oil-based or standard acrylic paints may be used. Follow paint manufacturer’s instructions for paint and primer application.

WARNING! Risk of Injury! Risk of Explosion! Install fasteners as instructed.

- Gas train could be damaged causing a gas leak.
- Electrical components could be damaged causing electrical shock.
- LED’S could be damaged.
- Glass installation could be obstructed.

Note: It is acceptable to use a high temperature silicone sealant to adhere drywall to lower access cover panel.

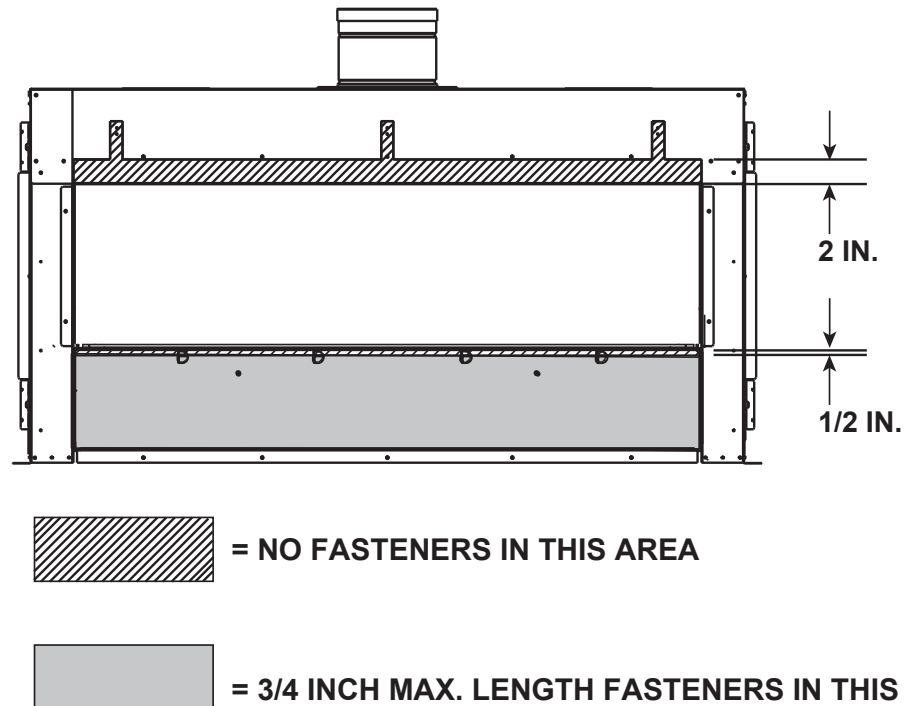

Figure 10.1 Screw Length Requirements

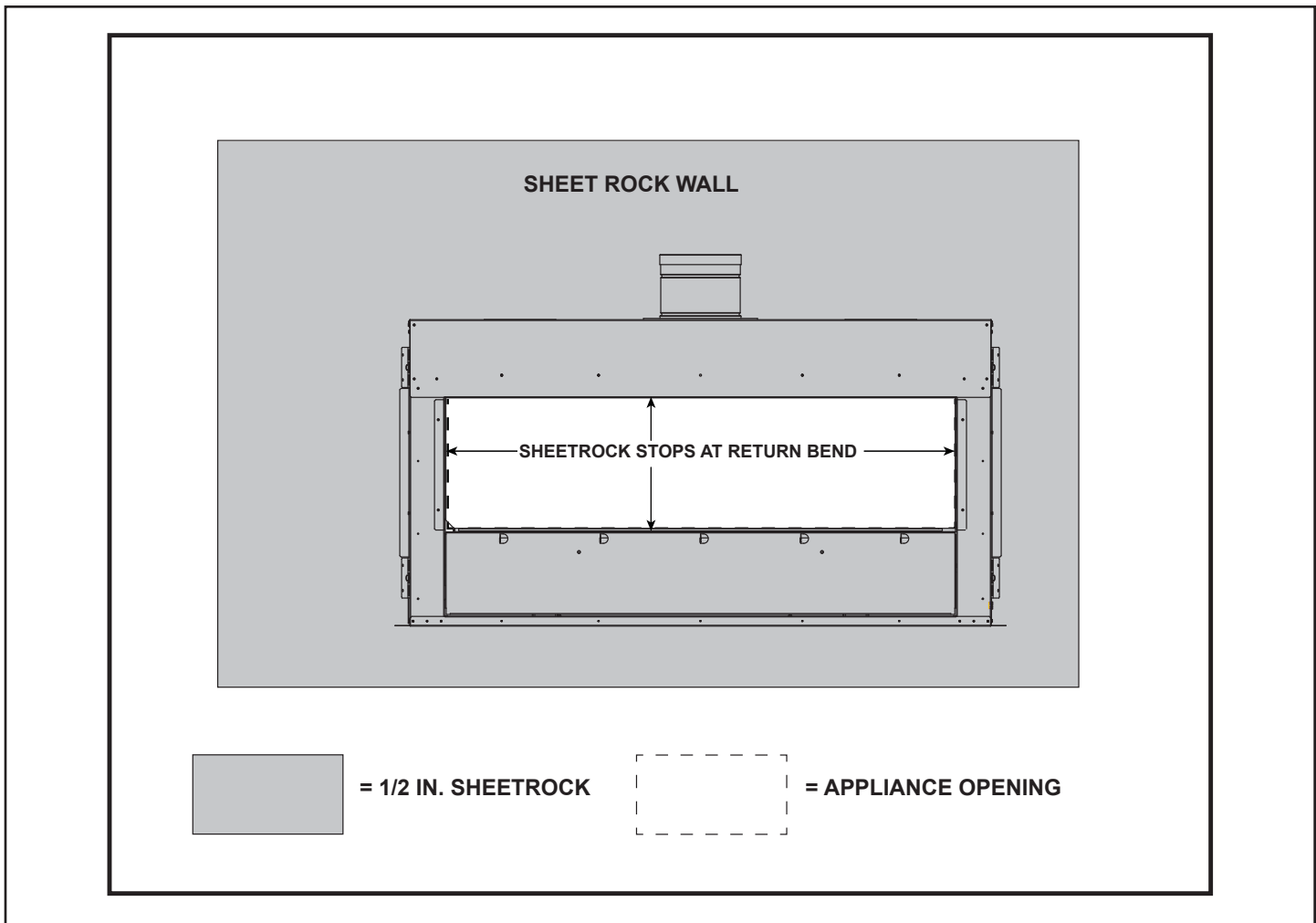

Figure 10.2 Sheetrock Detail for Both Finishing Methods

B. Clean Face Finish (Black Glass Interior)

PRIMO48-CF PRIMO48ST-CF
 PRIMO60-CF PRIMO60ST-CF
 PRIMO72-CF PRIMO72ST-CF

The PRIMO appliance can be finished with 1/2 inch sheetrock. Non-combustible finishing is not required.

Preparation

1. Install 1/2 inch sheetrock on wall. Figure 10.3 shows the PRIMO installed. Sheetrock (1/2 inch) has been installed up to the top, bottom and sides of appliance opening as shown in Figure 10.2 and 10.3. See Section 10.A for more details regarding facing material.

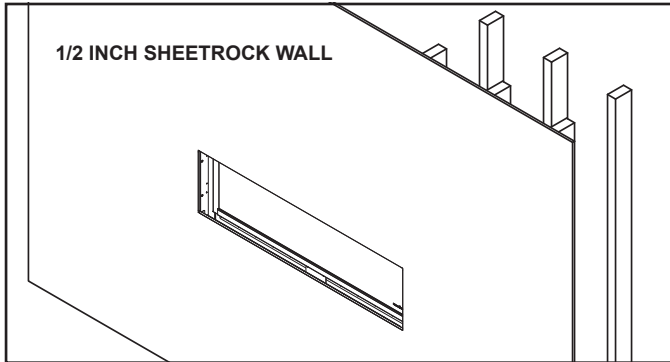

Figure 10.3

2. Install sheetrock trim strips as shown in Figure 10.4 on all sides of appliance. Sheetrock trim strips are included with the appliance. Cut the strips to the required length and install them using staples. See Figure 10.4 for placement of trim strips.

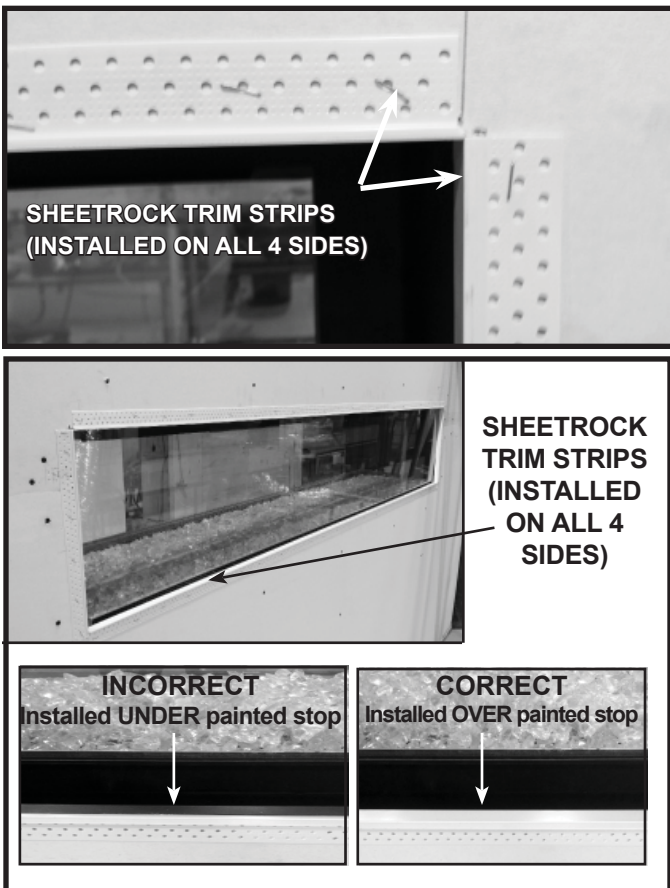

Figure 10.4. Install Sheetrock Trim Strips

3. Apply the sheetrock mud. When applying the mud, feather it evenly around the opening throughout the zone shown in Figure 10.5. A smooth, even surface, covering a wide area of the wall is desired for best results. For best results, follow the tips below.

To Reduce the Risk of Sheetrock Cracking: DO
Use all purpose joint compound.
Use eggshell paint (gloss or semi-gloss).
Tape over trim strips.

To Avoid Sheetrock Cracking: DO NOT
Use a quick set or light weight joint compound.
Use flat paint.

Trim Strip Joint-Crack Prevention and Repair

Trim strip joints around the fireplace will be affected by exposure to increased temperatures, along with other environmental and structural factors. The specific methods presented above will help prevent or minimize development of cracks.

If a crack does emerge, it can be permanently repaired by filling it with spackling paste or paintable latex caulk, followed by repainting. Fine cracks can be repaired using an additional coat of eggshell paint.

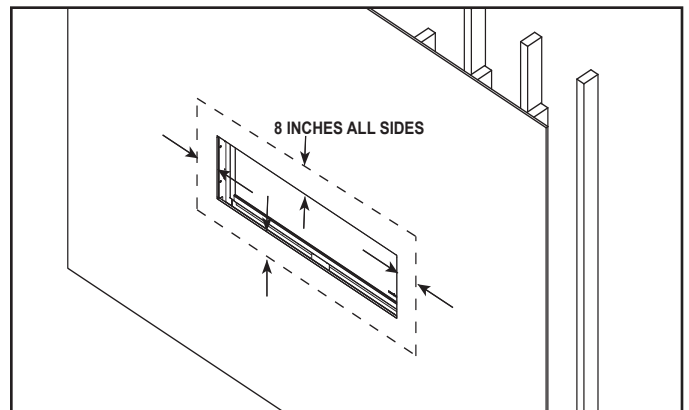

Figure 10.5 Feather Mud Evenly

4. Glass Panel Instructions

KIT COMPONENTS

- (1) Left Glass Panel
- (1) Right Glass Panel
- (1) Back Glass Panel (Single-sided models only)
- (3) Glass Retaining Brackets
- (2) Glass Clips

Single-Sided Models:

Set back glass panel, in location A in Figure 10.6 into firebox. Back panel will sit on the heads of the screws holding the media tray in place. Set back glass panel against the back wall of the firebox with the smooth side of the

glass facing outward. Place retaining bracket over panel so holes in the bracket are against the firebox back. Use two self-drilling screws to secure to the firebox back. Ensure glass panel is stationary. See Figure 10.7.

Position the glass clip as shown in Figure 10.8.

NOTICE: Fasteners are not used with glass clip.

Set left side glass panel, in location B in Figure 10.6, into firebox with the smooth side facing outward. Place retaining bracket over panel so holes in the bracket are against the firebox side. Use two self-drilling screws to secure to the firebox side. See Figure 10.7. Ensure glass panel is stationary.

Repeat for right side panel.

See-Through Models:

Position the glass clip as shown in Figure 10.8.

NOTICE: Fasteners are not used with glass clip.

Set left side glass panel, labeled B in Figure 10.6, into firebox with the smooth side facing outward. Place retaining bracket over glass panel so holes in the bracket are against the firebox side. Use two self-drilling screws to secure the bracket to the firebox side. See Figure 10.7. Repeat for right side panel.

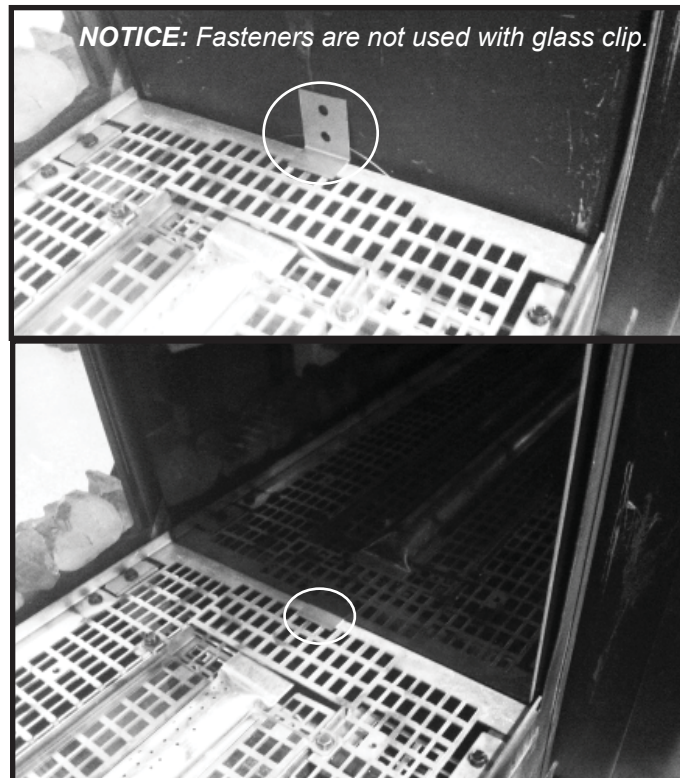

Figure 10.8 Position Glass Clip and Install Glass Panel

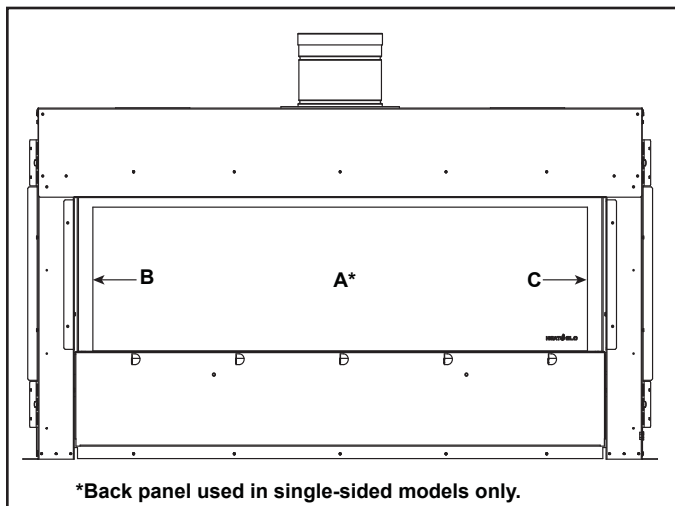

Figure 10.6. Placement of Panels

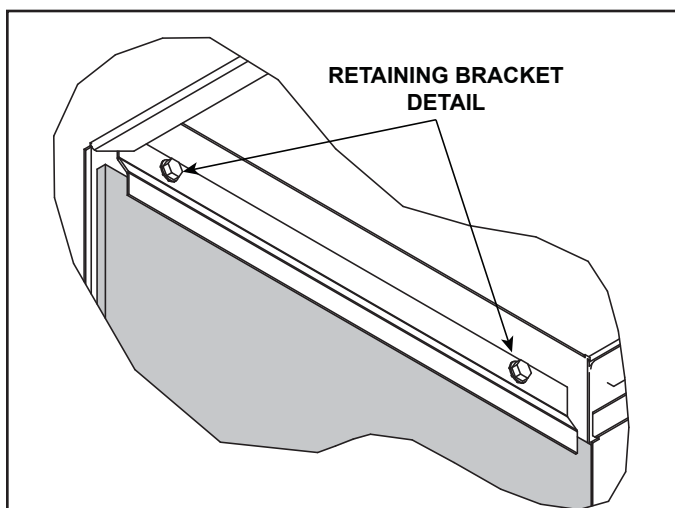

Figure 10.7. Retaining Bracket Installation

5. Break the barrier glass support into two pieces as shown in Figures 10.9 and 10.10. Make the hand bends as shown in Figure 10.11 to form the glass supports

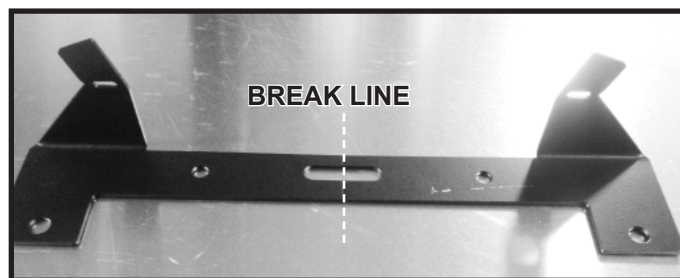

Figure 10.9. Barrier Glass Support

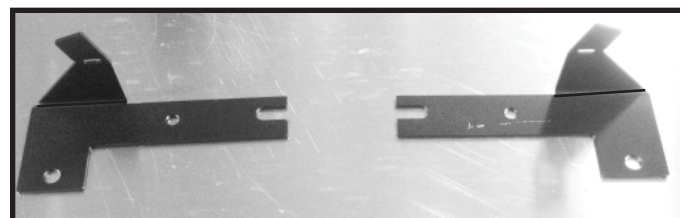

Figure 10.10. Break Barrier Glass Support

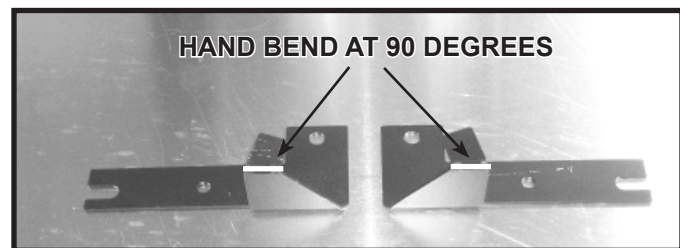

Figure 10.11. Form Barrier Glass Support

6. Install barrier glass supports on bottom left and right sides using an existing screw, a self-tapping screw, and shoulder bolt. See Figure 10.12 and 10.13. Install rubber bumpers as shown in Figure 10.12 to protect the barrier glass.

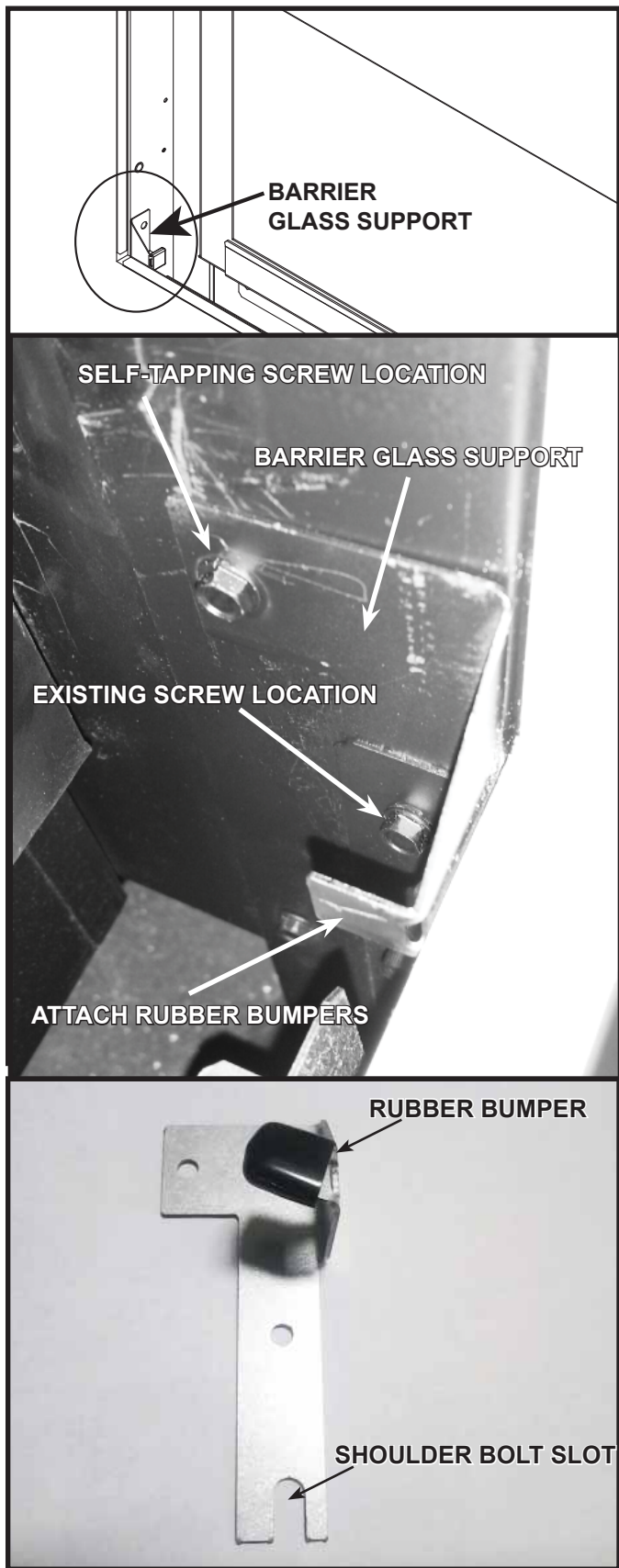

Figure 10.12 Install Barrier Glass Supports

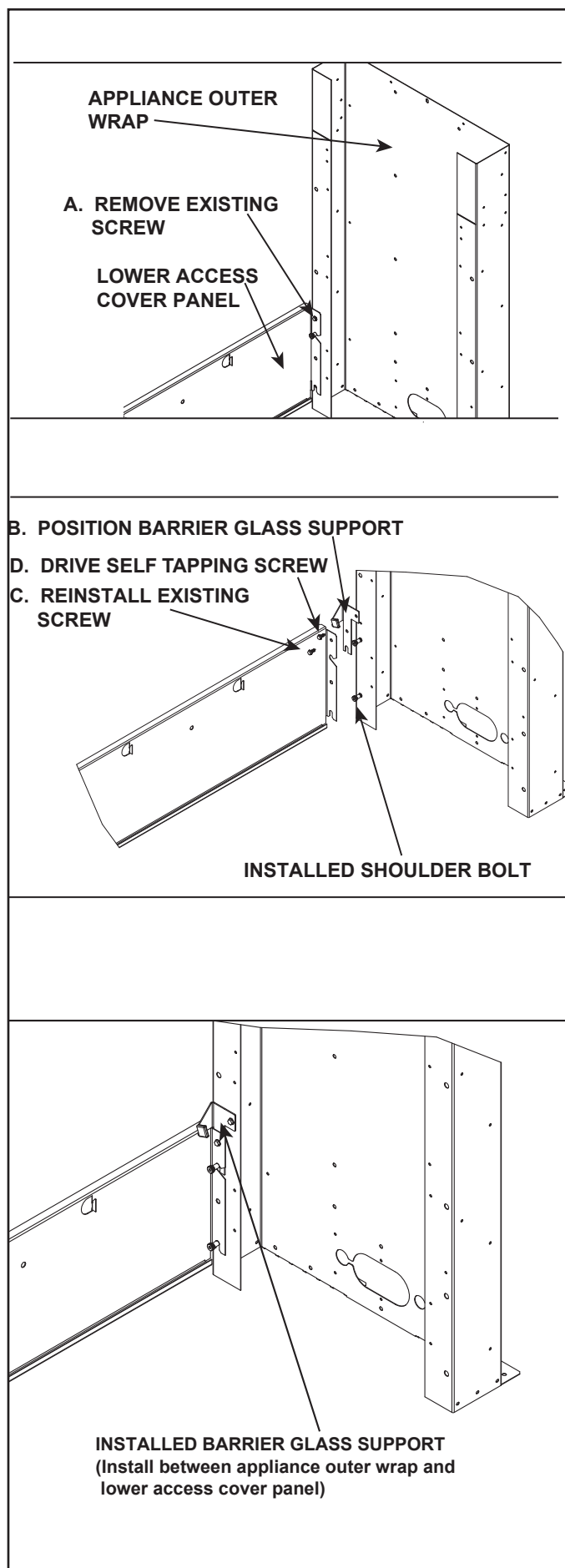

Figure 10.13 Install Barrier Glass Supports

- Set transition media tray into position as shown in Figure 10.16. The return bends are at the bottom of the tray. The rear return bend should be positioned in between the glass frame and the glass frame bracket. Ensure tray is positioned flush with appliance opening.

- Install glass transition panel bracket on left and right sides of appliance opening using two self-tapping screws. See Figures 10.14, 10.15 and 10.16 for details.
- Install transition glass panels by securing with tabs on left and right sides of appliance. See Figures 10.16 and 10.17.

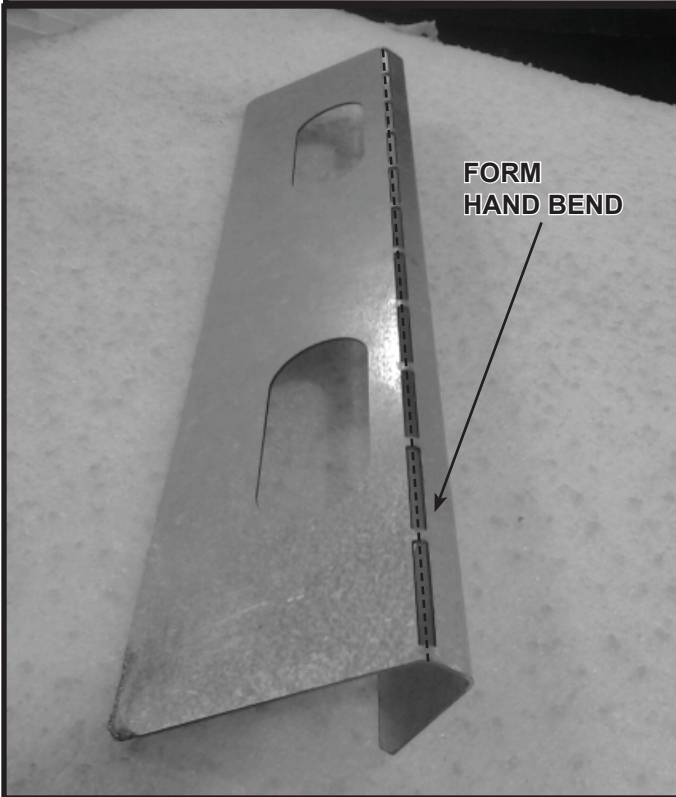

Figure 10.14 Form Transition Glass Panel Bracket

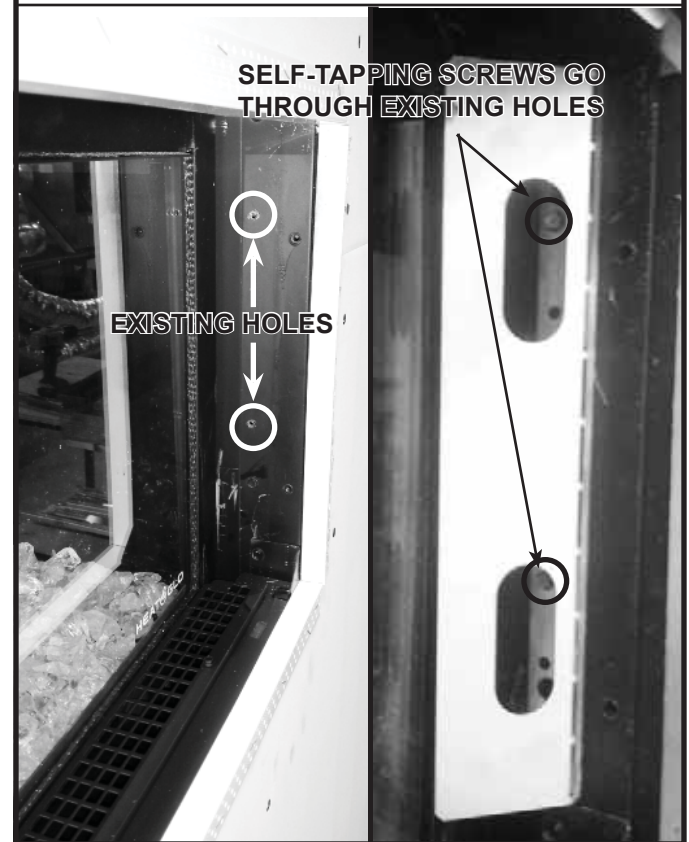
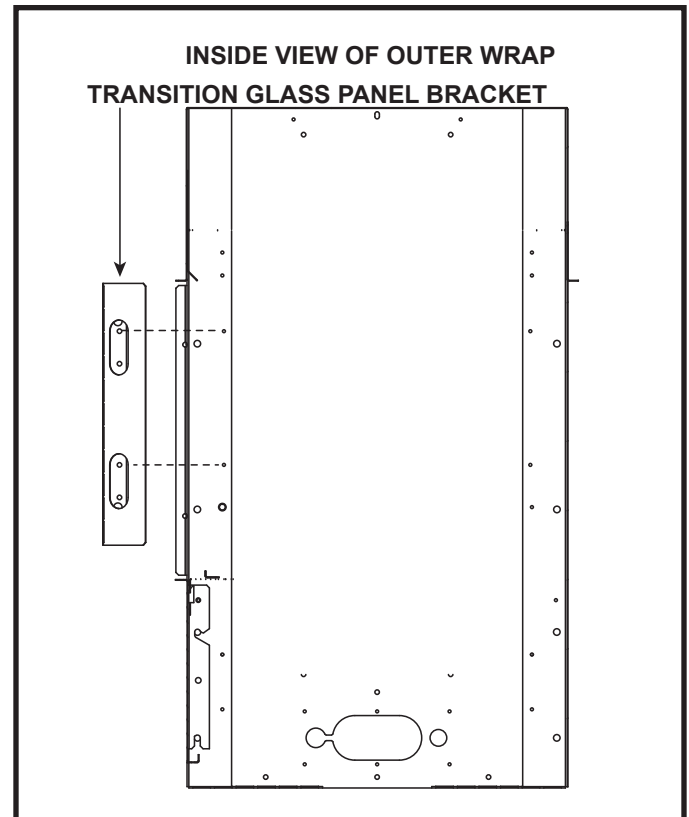

Figure 10.15 Install Transition Glass Panel Bracket

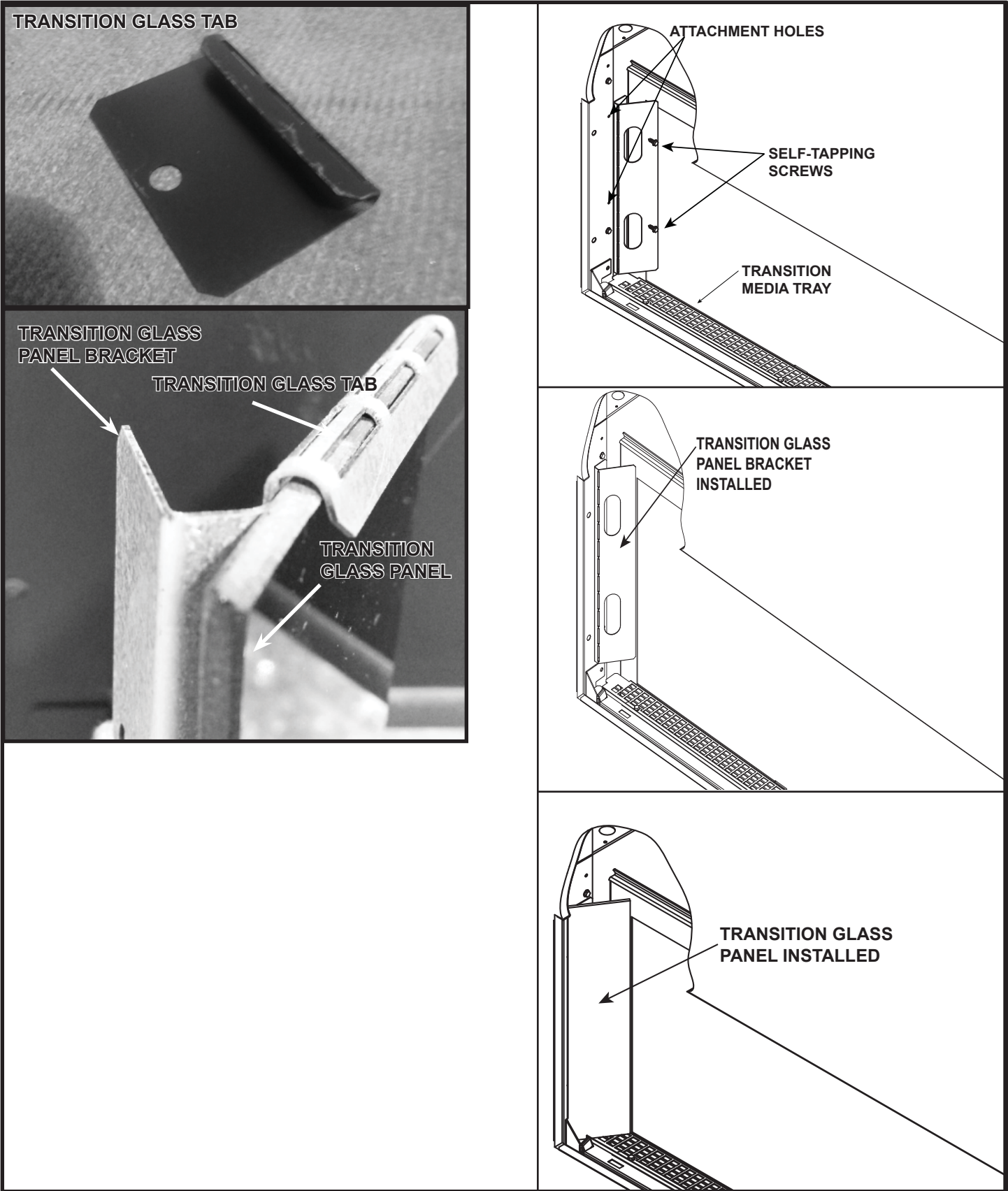

Figure 10.16 Install Transition Glass Panel

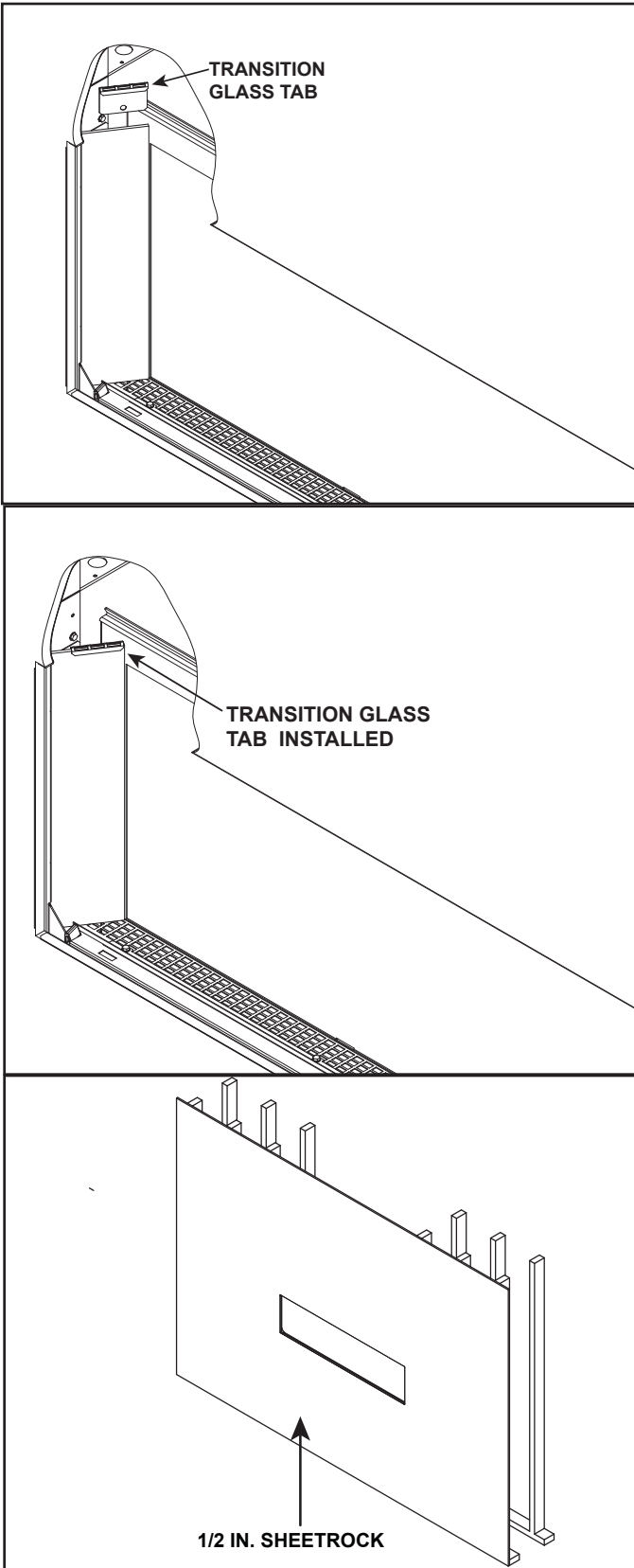
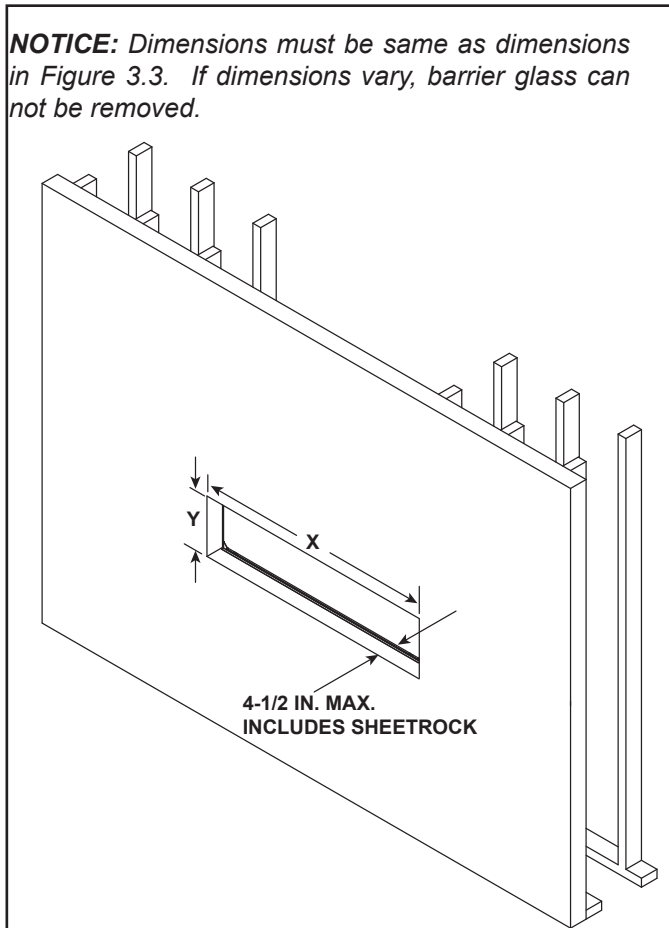

Figure 10.17 Transition Glass Tab Installation and Finished Wall

Clean Face Finishing Option

Combustible or Non-Combustible



NOTICE: Dimensions must be same as dimensions in Figure 3.3 for Clean Face Finish. If dimensions vary, barrier glass cannot be removed.

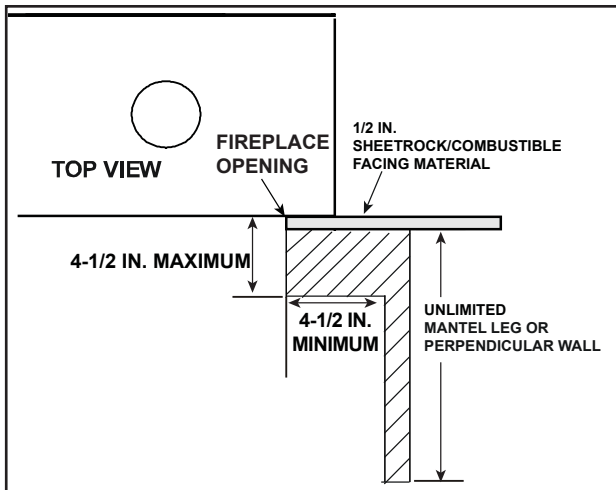

MODEL	X Min.	Y Min.
PRIMO48/48ST	51	13-3/8
PRIMO60/60ST	63	13-3/8
PRIMO72/72ST	75	13-3/8

SERVICE PARTS

DESCRIPTION	PRIMO48	PRIMO48ST
KIT	PRIMO48-CF	PRIMO48ST-CF
Firebox Panel Glass Assembly	2300-060	2301-060
Transition Panel Glass Assembly	2310-032	2310-032
Glass Retaining Bracket	2300-133	2300-133
Barrier Glass Support	2310-134	2310-134
Rubber Bumper	2310-140	2310-140
Transition Glass Tab	2310-145	2310-145
Clean Face Barrier Glass	GLA2310-106	GLA2310-106
Transition Glass Panel Bracket	2310-120	2310-120

DESCRIPTION	PRIMO60	PRIMO60ST
KIT	PRIMO48-CF	PRIMO48ST-CF
Firebox Panel Glass Assembly	2321-060	2301-060
Transition Panel Glass Assembly	2310-032	2310-032
Glass Retaining Bracket	2300-133	2300-133
Barrier Glass Support	2310-134	2310-134
Rubber Bumper	2310-140	2310-140
Transition Glass Tab	2310-145	2310-145
Clean Face Barrier Glass	GLA2329-106	GLA2329-106
Transition Glass Panel Bracket	2310-120	2310-120

DESCRIPTION	PRIMO72	PRIMO72ST
KIT	PRIMO48-CF	PRIMO48ST-CF
Firebox Panel Glass Assembly	2331-060	2301-060
Transition Panel Glass Assembly	2310-032	2310-032
Glass Retaining Bracket	2300-133	2300-133
Barrier Glass Support	2310-134	2310-134
Rubber Bumper	2310-140	2310-140
Transition Glass Tab	2310-145	2310-145
Clean Face Barrier Glass	GLA2336-106	GLA2336-106
Transition Glass Panel Bracket	2310-120	2310-120

Figure 10.18 Clean Face Finishing Options - Combustible or Non-Combustible (Recessed Wall)

C. Black Granite Surround Finish (Black Granite Interior)

PRIMO48-GR PRIMO48ST-GR
 PRIMO60-GR PRIMO60ST-GR
 PRIMO72-GR PRIMO72ST-GR

Wall Preparation

Figure 10.19 shows the PRIMO installed in a sheetrocked wall.

1. Install 1/2 inch sheetrock up to appliance top, bottom and sides of the appliance opening as shown in Figure 10.19 and 10.20.
2. Do not install the sheetrock trim strips which are included with the appliance. The strips would keep the granite from being installed level. They are required for the Clean Face finishing method only.
3. A flat sheetrock surface will allow for the granite surround to sit flat. Sheetrock seams will lead to granite not being level. See Figure 10.19.

NOTICE: DO NOT install sheetrock trim strips. Granite pieces will not be level.

The wall and granite pieces must be clean, free from dust and construction debris, and dry before beginning installation. Dust or moisture may prohibit the adhesive from performing effectively.

For the adhesive, choose a 100% silicone or strong construction adhesive with an aggressive tack intended to hold heavy material and that also is approved for high temperatures (250°F minimum).

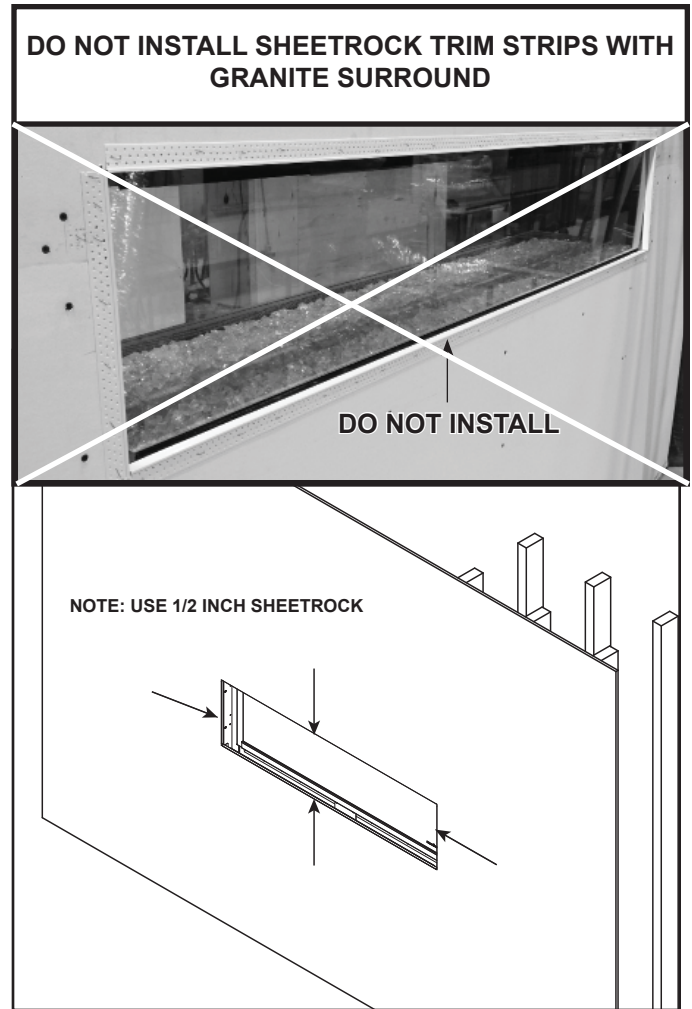

Figure 10.20. Do Not Install Sheetrock Trim Strips

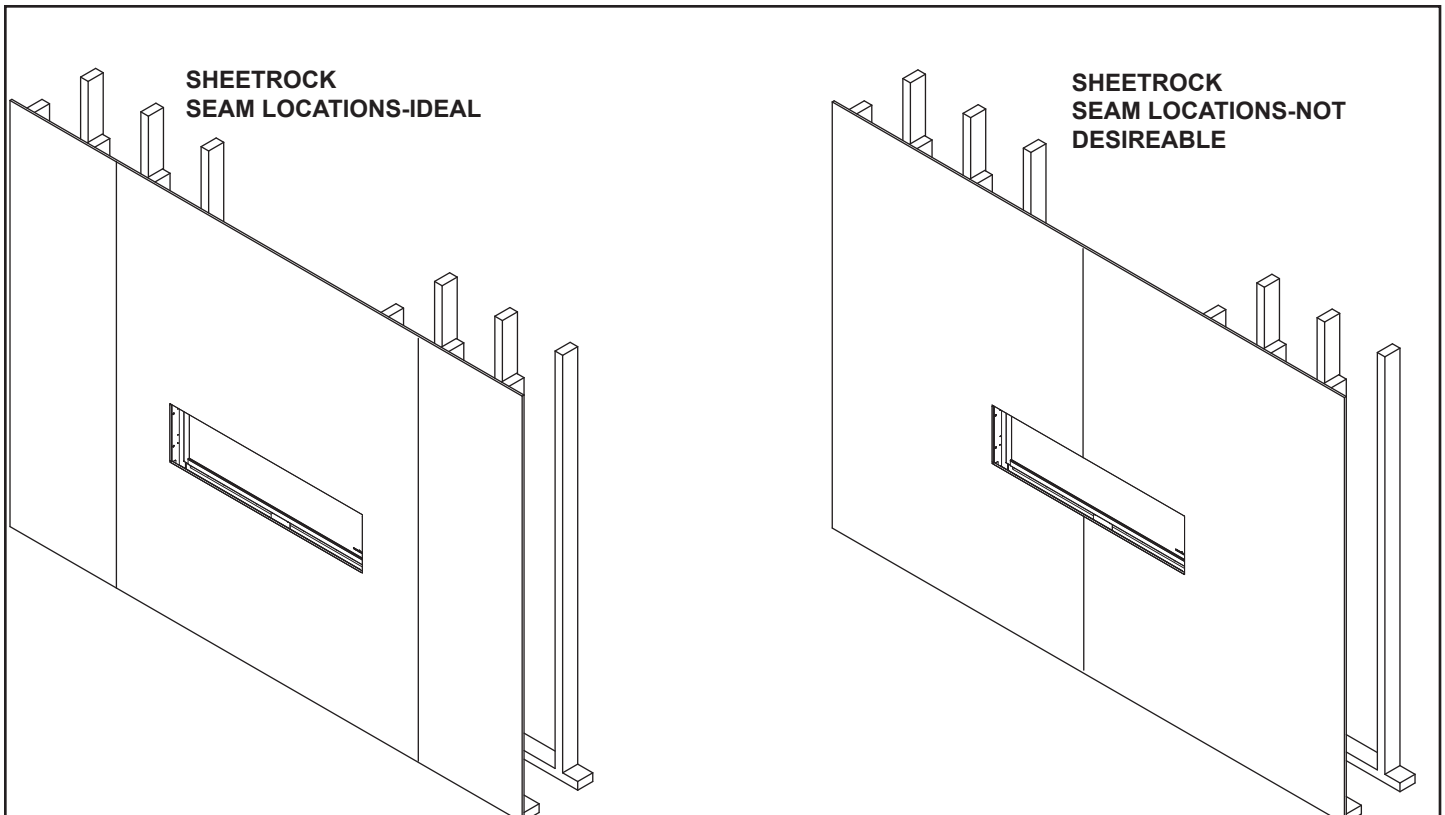

Figure 10.19. Sheetrock Seams - Prior to Granite installation

Granite Panel Installation

KIT COMPONENTS

- (1) Left Panel
- (1) Right Panel
- (1) Back Panel (Single-sided models only)
- (2) Retaining Brackets

CAUTION! Risk of Injury! It is recommended that granite panel installation and removal be performed by two qualified service technicians.

Inside Granite Back Panel Weights		
PRIMO48	PRIMO60	PRIMO72
51 lbs	63.5 lbs	76 lbs

See-Through Models: Start at Step 3.

1. Single-Sided Models:

Set back panel, in location A in Figure 10.21, into firebox. Back panel will be held in place by the side panels and will sit on the heads of the screws holding the media tray in place. Set back panel against the back wall of the firebox with the polished side of the panel facing outward. Hold back panel in place while installing the left/right panels per step 2.

2. Single-Sided Models:

Set left side panel, in location B in Figure 10.21, into firebox with the polished side facing outward. Place retaining bracket over panel so holes in the bracket are against the firebox side. Use two self-drilling screws to secure the bracket to the firebox side. See Figure 10.22. Repeat for right side panel.

3. See-Through Models:

Set left side panel, in location B in Figure 10.21, into firebox with the polished side facing outward. Place retaining bracket over panel so holes in the bracket are against the firebox side. Use two self-drilling screws to secure the bracket to the firebox side. See Figure 10.22. Repeat for right side panel.

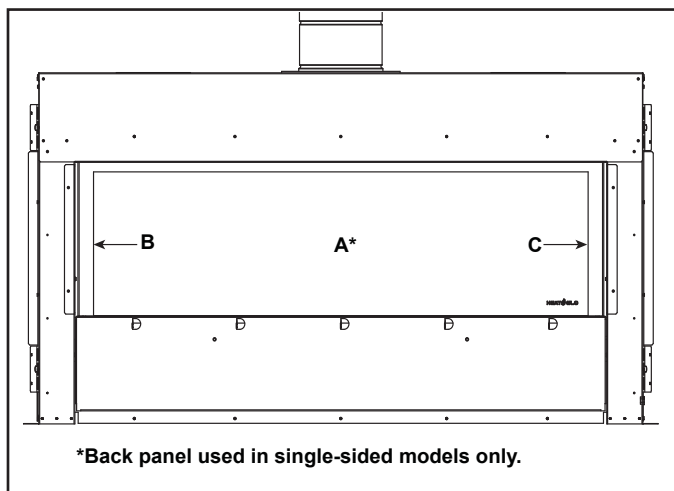

Figure 10.21 Placement of Panels

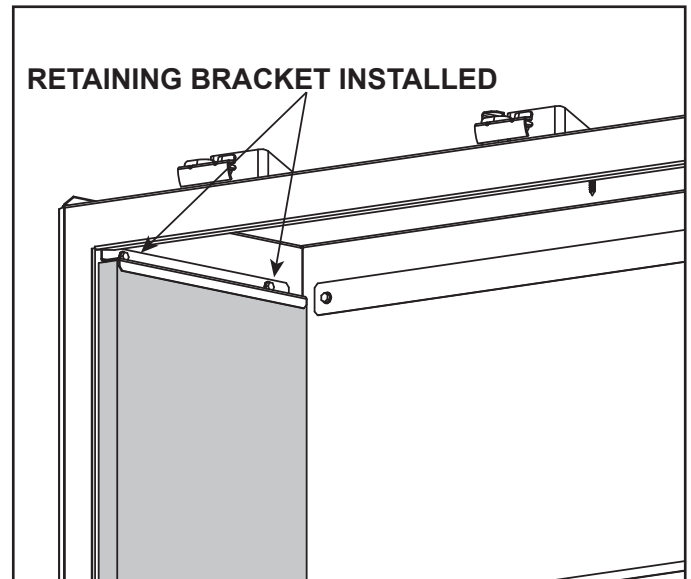

Figure 10.22. Granite Retaining Bracket

Granite Surround Installation

Note: Install granite pieces in the order indicated in Figure 10.23.

1. Install leveling shoulder bolts to the granite transition brackets. See Figure 10.24. The bolts can be used to level the side granite pieces.
2. Install granite transition bracket on left and right sides of appliance opening as shown in Figure 10.24. Attach brackets with the two shoulder bolts and tighten.

CAUTION! Risk of Injury! Granite is heavy. Installation of top and bottom granite pieces requires at least two people.

Granite Weights Top/Bottom Pieces (Each)		
PRIMO48	PRIMO60	PRIMO72
29.4 lbs	35.4 lbs	41.5 lbs

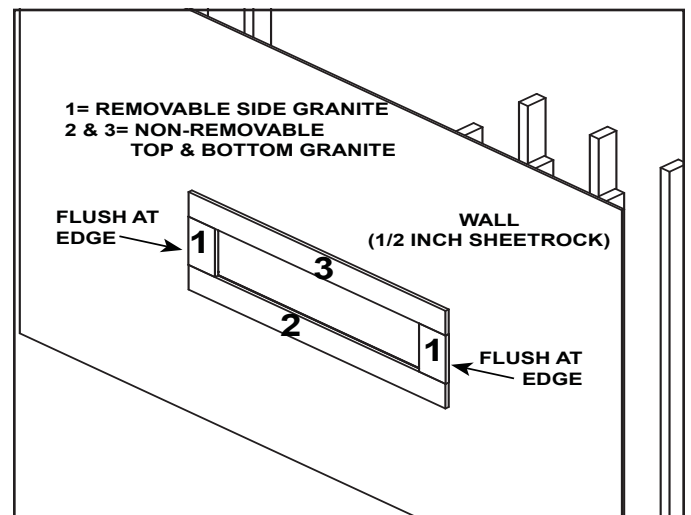

Figure 10.23 Sequence of Granite Piece Placement

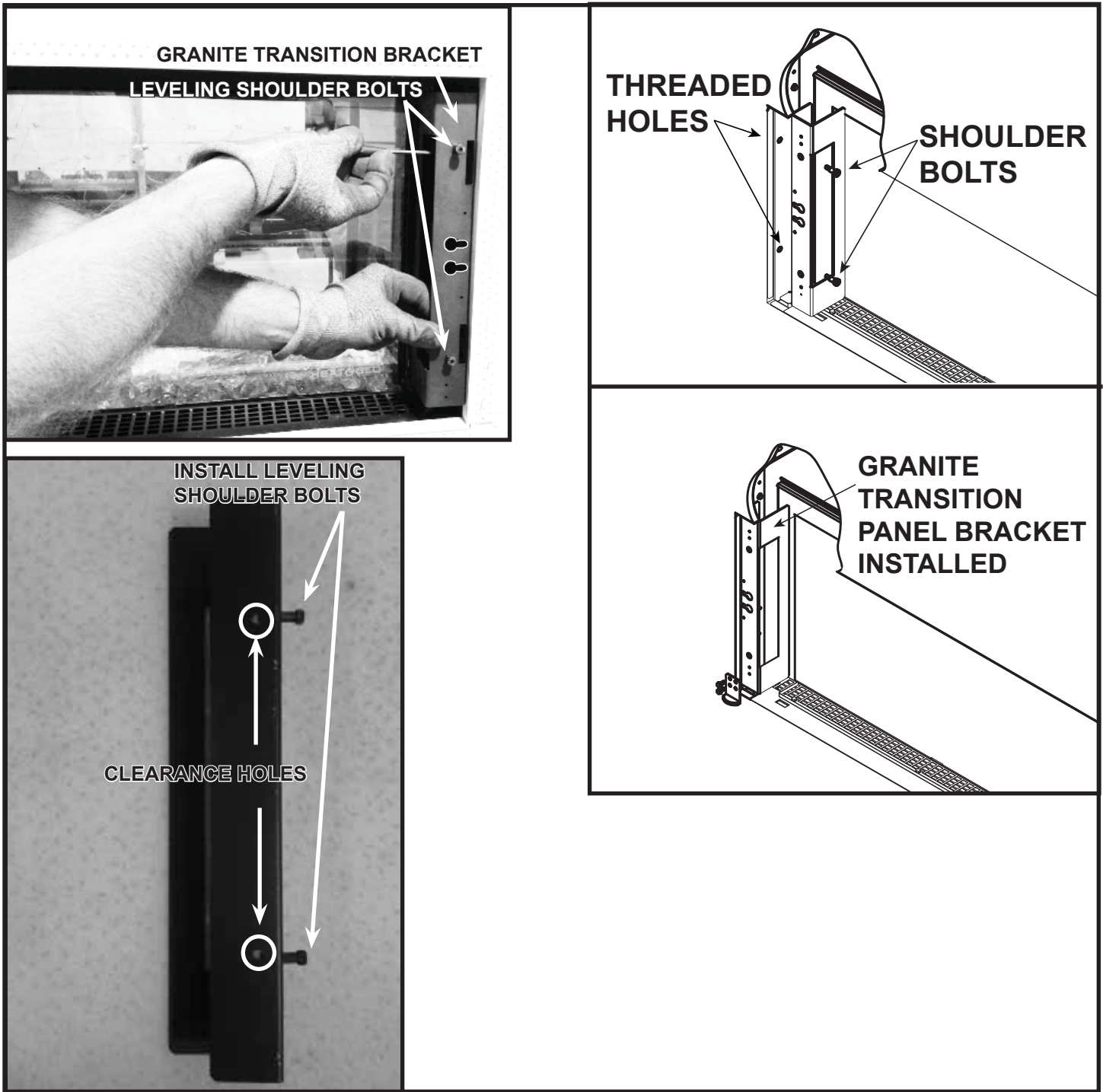

Figure 10.24. Install Granite Transition Brackets

3. Install right outside granite by aligning the bolts on the back of the granite piece with bottom hole on granite transition panel bracket. Insert the bolt* in the bottom slot. See Figure 10.25. Align and slide toward outside of appliance. Repeat with left side granite.

*Bolt detail: M6-1.00 x 25 Hex Head

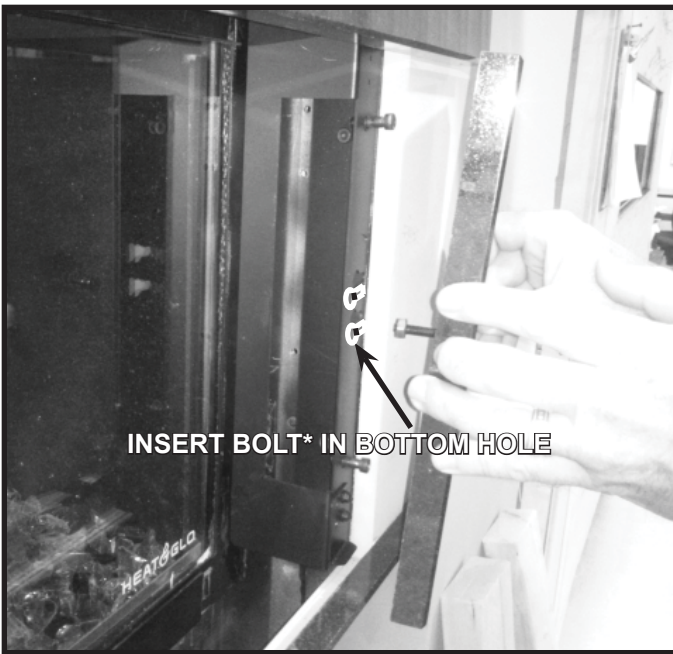

Figure 10.25. Install Side Granite Pieces

NOTICE! Verify the left and right side granite locations before installing the top and bottom granite. See Figures 10.25, 10.27, 10.29.

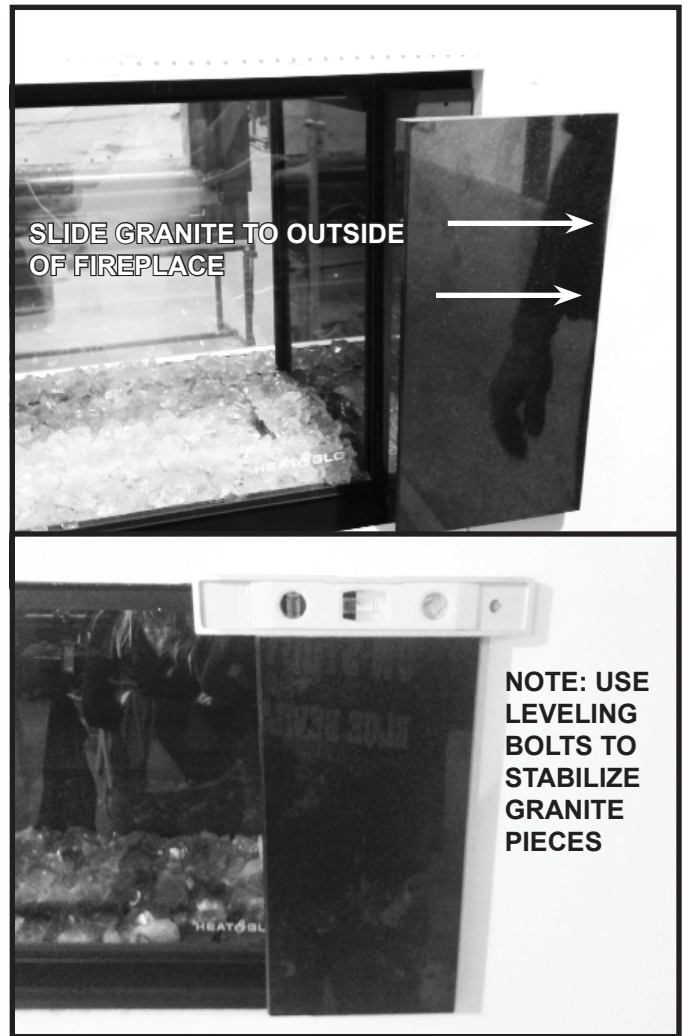

Figure 10.26. Right Side Granite Piece Installed and Leveled

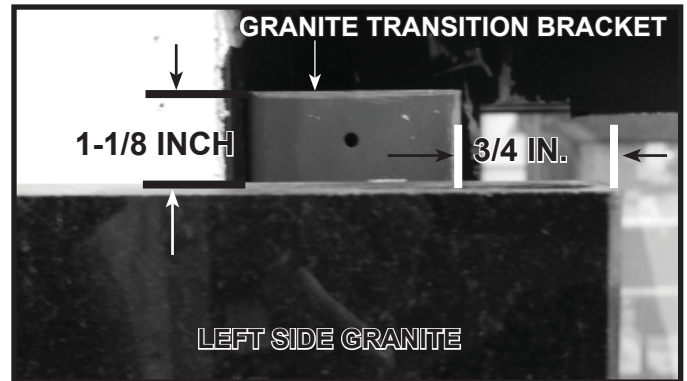

Figure 10.27. Verify Side Granite Reference Dimensions

- Slide both side granite pieces outward as shown in Figure 10.29. Verify dimensions in Figure 10.25, 10.27 and 10.29.
- Place plastic washers as shown in Figure 10.29. The washers serve as spacers for granite placement. If washers are not used, the side granite will be difficult to remove.
- Apply a generous amount of adhesive to the back side of the bottom granite piece. The same method will be used for top and bottom pieces. See Figure 10.28 for appropriate zone to apply adhesive. DO NOT apply adhesive too close to the edges. Leave 1 in. around edges. Avoid leakage of adhesive around edges by not applying it too close to the edge of the granite. Place

the bottom piece and hold with braces and clamps to support granite.

NOTICE! Verify the left and right side granite is correctly installed per Figure 10.25, 10.27 and 10.29.

- Align the top edge with the bottom of the left and right outside pieces so the edges of the bottom piece are flush with the side pieces. See Figure 10.29. Secure the bottom granite in place with clamps or braces. See Figure 10.29. Do not remove supports or operate fireplace for 24 hours.
- Apply a generous amount of adhesive to the back side of the top granite piece. See Figure 10.28. The granite material is heavy and will need to be adequately secured to the wall.

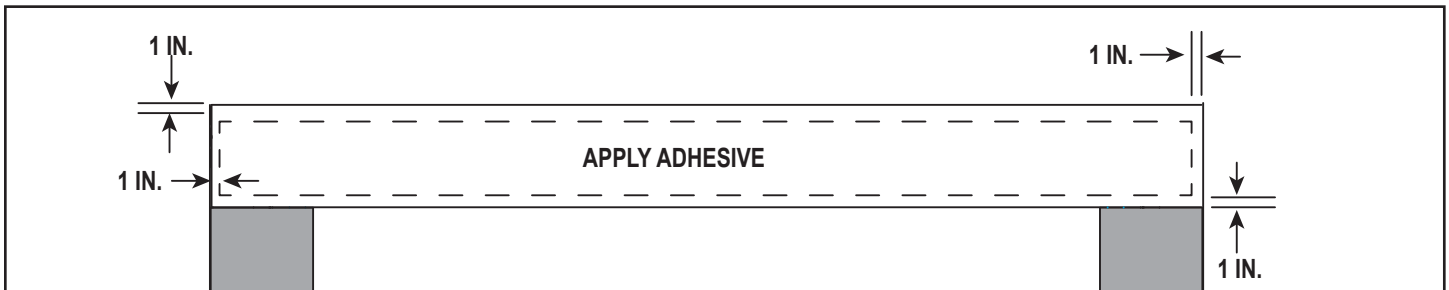

Figure 10.28. Apply Adhesive For Top and Bottom Granite

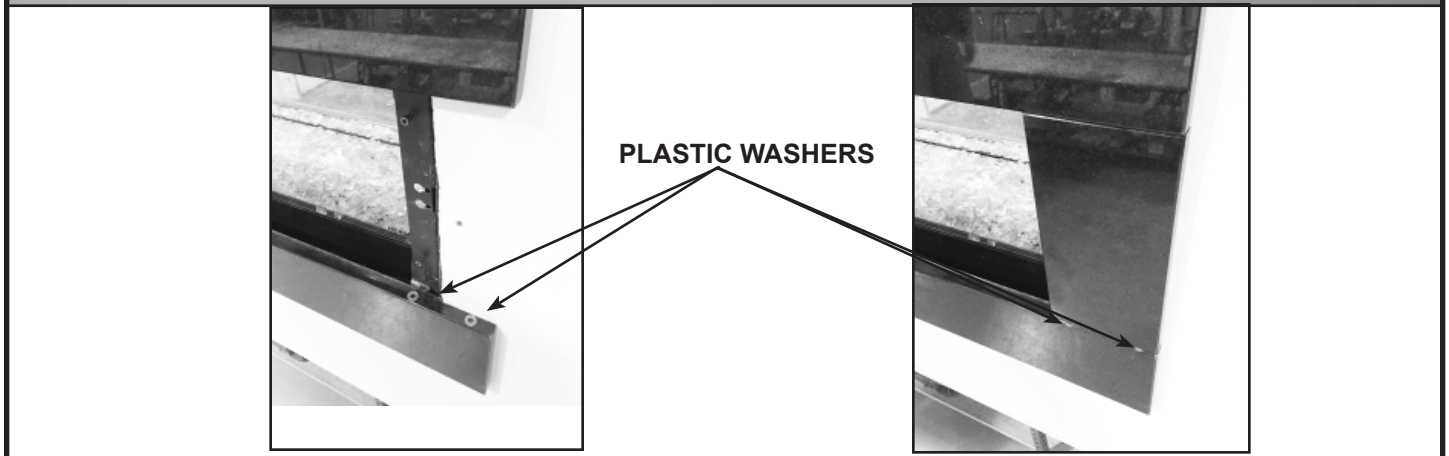
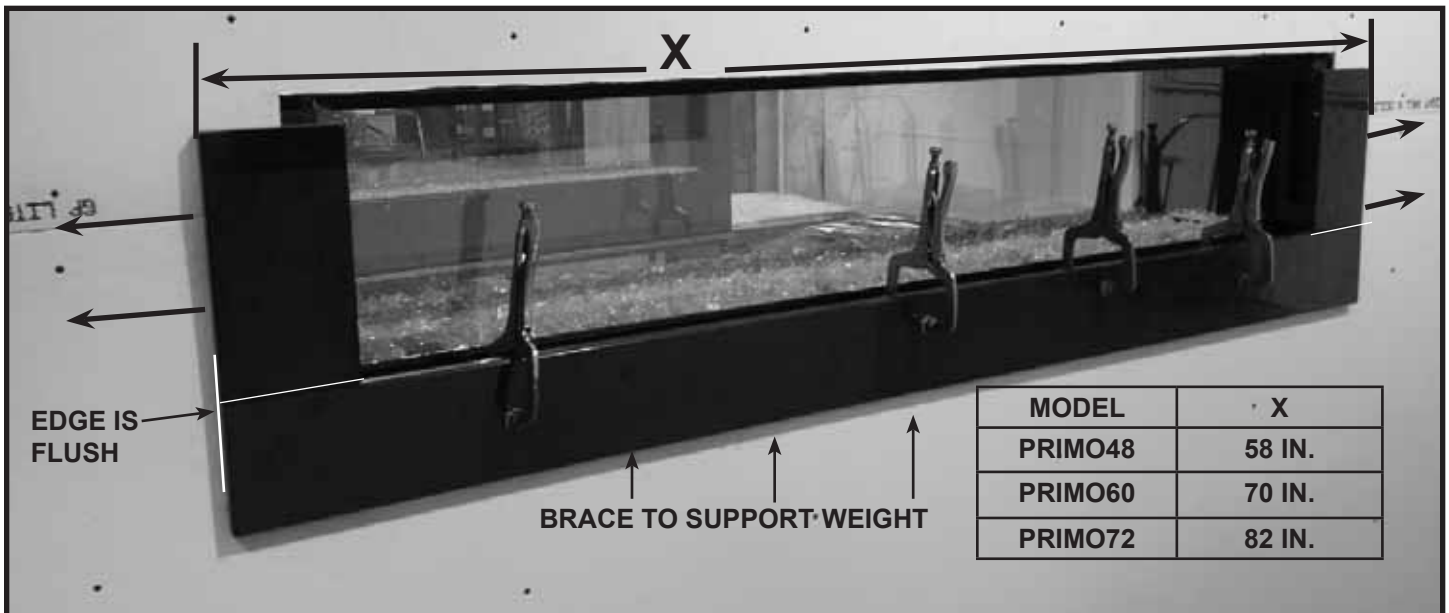

Figure 10.29 Bottom Granite Piece Installed

9. Center the top granite piece in position on top of the two side pieces ensuring that the left and right edges of the top piece are flush with the edges of the left and right outside granite pieces. See Figure 10.23.
10. Secure the top granite in place with clamps or braces.

NOTICE! Allow the adhesive to dry 24 hours. Remove and discard plastic washers.

11. Install the transition media tray in the location as shown in Figure 10.31. Remove side granite for access.
12. Bend the tabs on each end of the transition media ledge. This will allow for granite clearance. See Figure 10.30.
13. Install the transition granite panels as shown in Figure 10.31.
14. Place the granite locating tab on the top of the transition granite. The bracket is used to secure the transition granite to the transition panel bracket. See Figure 10.31.
15. Install the glass support bracket. See Figure 10.31.
16. Attach the rubber bumpers to the glass support bracket. See Figure 10.31.
17. Insert top of barrier glass behind granite and place the bottom on barrier glass supports. Center the barrier glass. Secure the D-Shaped glass retaining brackets on left and right sides with screws. See Figure 10.32.
18. Reinstall side granite. See Figure 10.25.

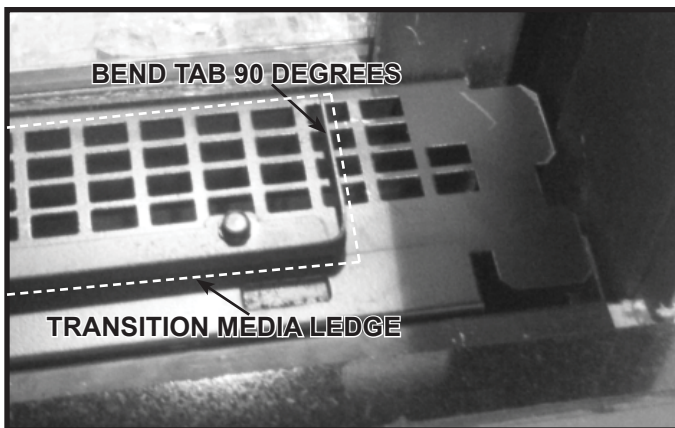

Figure 10.30 Transition Media Tray Installed

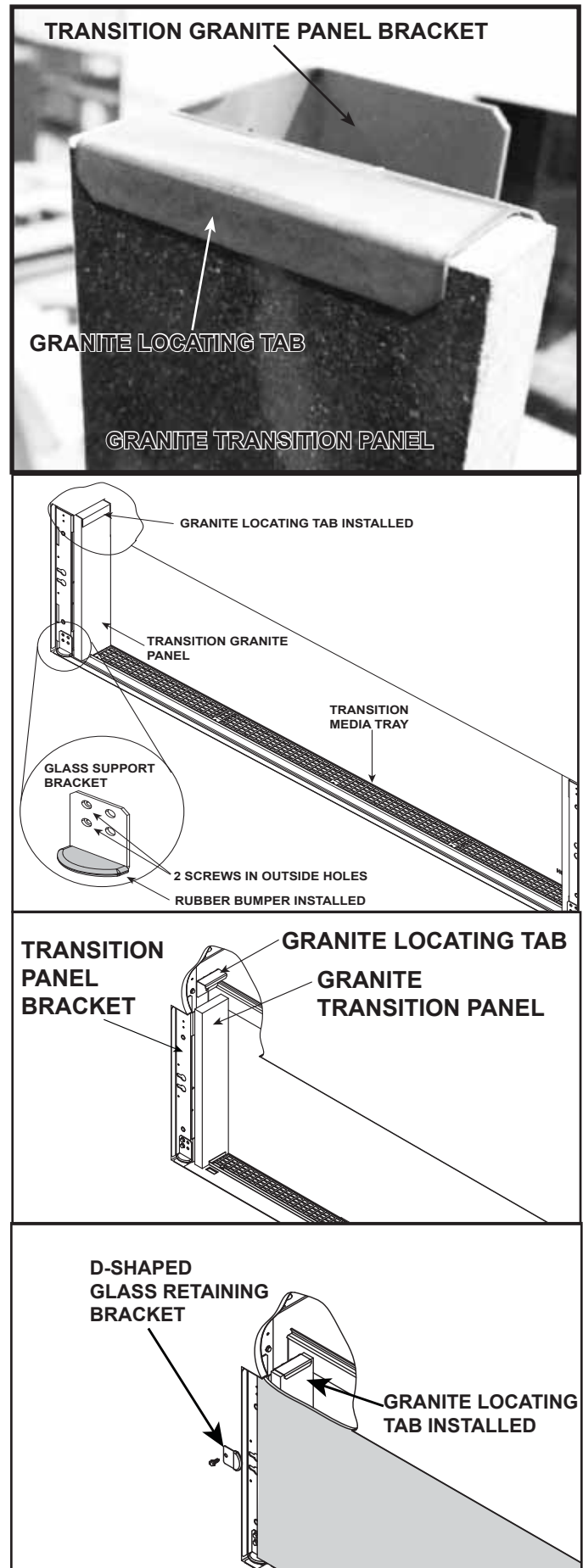

Figure 10.31. Install Transition Granite and Granite Locating Tab (Shown with Side Granite Removed)

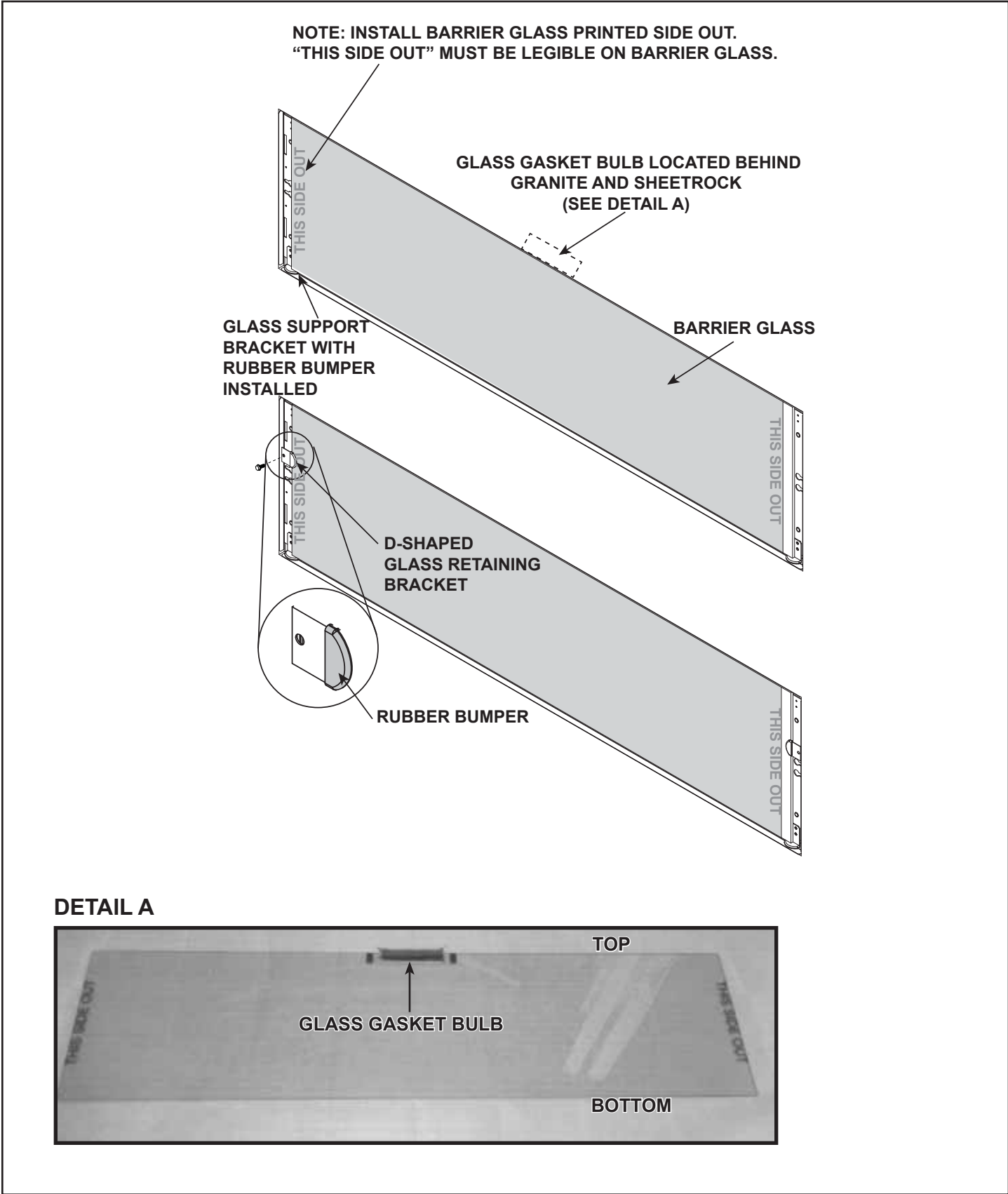
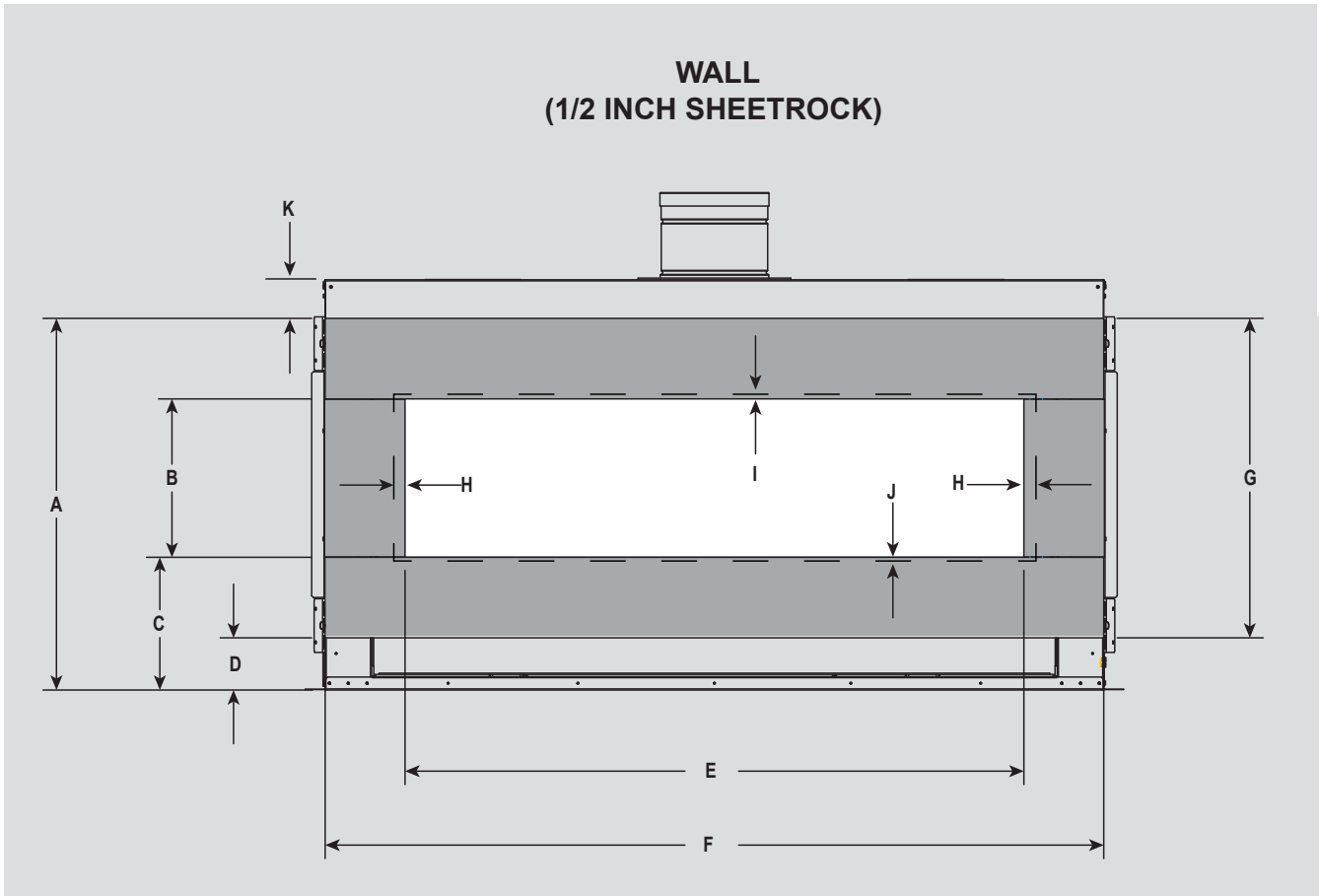



Figure 10.32. Install Barrier Glass and D-Shaped Glass Retaining Bracket (Shown with Side Granite Removed)

SERVICE PARTS

DESCRIPTION	PRIMO48	PRIMO60	PRIMO72
GRANITE KIT	PRIMO48-GR PRIMO48ST-GR	PRIMO60-GR PRIMO60ST-GR	PRIMO72-GR PRIMO72ST-GR
TRANSITION PANEL BRACKET	2310-023	2310-023	2310-023
SURROUND BARRIER GLASS	GLA2310-101	GLA2329-101	GLA2336-101
D-SHAPED GLASS RETAINING BRACKET	2310-116	2310-116	2310-116
GLASS SUPPORT BRACKET	2310-119	2310-119	2310-119
GRANITE LOCATING TAB	2310-146	2310-146	2310-146
SHOULDER BOLT	319-835	319-835	319-835
RUBBER BUMPER	383-221	383-221	383-221
GRANITE RETAINING BRACKET	2310-143	2310-143	2310-143
GRANITE SURROUND TOP/BOTTOM	SRV2310-702	SRV2329-702	SRV2336-702
TRANSITION GRANITE PANEL	SRV2310-704	SRV2310-704	SRV2310-704
GRANITE BACK PANEL (SINGLE SIDE)	SRV2310-707	SRV2329-707	SRV2336-707
GRANITE BACK PANEL (SEE THROUGH)	N/A	N/A	N/A
GRANITE SURROUND SIDE	SRV2310-709	SRV2310-709	SRV2310-709
INSIDE GRANITE SIDE PANEL (SINGLE SIDE)	SRV2310-706	SRV2310-706	SRV2310-706
INSIDE GRANITE SIDE PANEL (SEE THROUGH)	SRV2311-706	SRV2311-706	SRV2311-706

NOTE: Sheetrock (1/2 inch) may be installed up to appliance opening.



 = 1/2 INCH SHEETROCK
  = APPLIANCE OPENING

 = GRANITE SURROUND
 (Installed on top of 1/2 inch sheetrock)

Location	PRIMO48/PRIMO48ST		PRIMO60/PRIMO60ST		PRIMO72/PRIMO72ST	
	Inches	Millimeters	Inches	Millimeters	Inches	Millimeters
A	27-11/16	703	27-11/16	703	27-11/16	703
B	11-13/16	300	11-13/16	300	11-13/16	300
C	9-7/8	251	9-7/8	251	9-7/8	251
D	3-7/8	98	3-7/8	98	3-7/8	98
E	46-1/16	1170	58-1/16	1475	70-1/16	1780
F	58	1473	70	1778	82	2083
G	23-13/16	605	23-13/16	605	23-13/16	605
H	2-1/2	64	2-1/2	64	2-1/2	67
I	1-1/4	32	1-1/4	32	1-1/4	32
J	1/2	13	1/2	13	1/2	13
K	3-3/4	82	3-3/4	82	3-3/4	82

Figure 10.33 Granite Finish Dimensions

D. Mantel and Wall Projections

Combustible or Non-Combustible Mantels

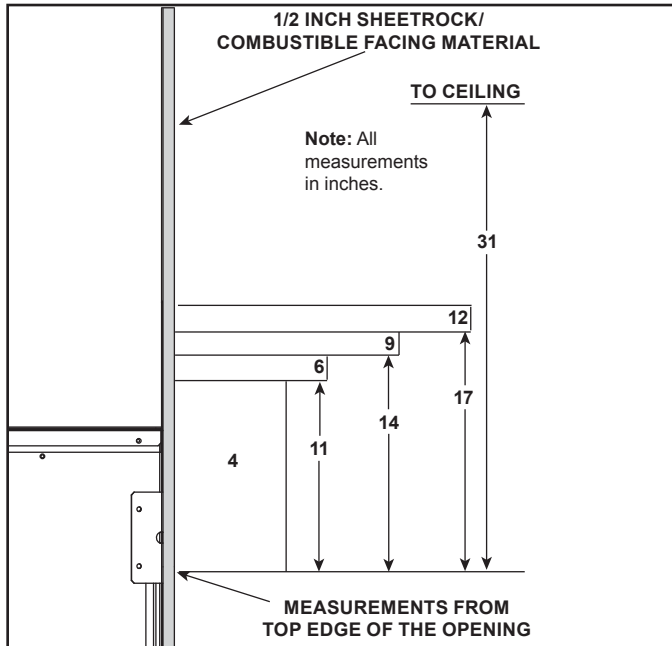

Figure 10.34 Minimum Vertical and Maximum Horizontal Dimensions of Combustibles or Non-Combustibles.

Mantel Legs Or Wall Projections Extending Past The Face Of The Fireplace (Combustible or Non-Combustible)

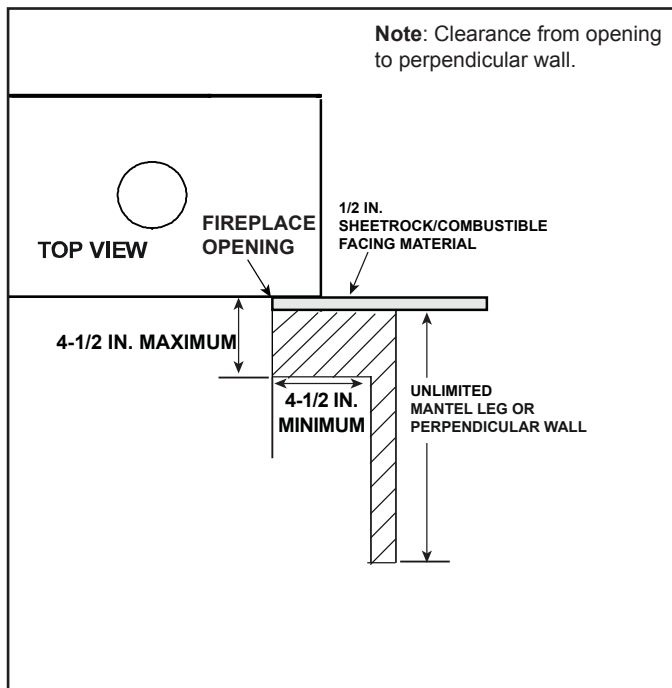

Figure 10.35 Mantel Leg or Wall Projections (Acceptable on both sides of opening)

11 Appliance Setup

A. Remove the Shipping Materials

Remove shipping materials from inside or underneath the firebox. Verify all components are with the fireplace.

B. Clean the Appliance

Clean/vacuum any sawdust that may have accumulated inside the firebox or underneath in the control cavity.

C. Install Burner Glass

Install the burner glass according to the instructions in Section 6.E.

D. Install Modern Log Set

An optional log set is available for use with the PRIMO models. Install the log set per instructions included with kit.

E. Install Media

A media kit is available for use with the PRIMO models. Install rock media according to instructions included with media kit.

F. Barrier Glass

WARNING! Risk of Injury! Handle barrier glass with care. Inspect the glass for cracks, chips or scratches.

- **DO NOT** strike, slam or scratch glass.
- **DO NOT** operate fireplace with glass removed, cracked, broken or scratched.
- Replace as a complete assembly.

CAUTION! Risk of Injury! Glass installation and removal must be performed by a qualified service technician. See chart below for barrier glass weights.

- **PRIMO60 AND PRIMO72 MODELS:** It is recommended that glass installation and removal be performed by two qualified service technicians.

CAUTION! Risk of Cuts or Abrasions. Wear protective gloves and safety glasses during installation. Sheet metal edges are sharp.

Barrier Glass Weights		
PRIMO48	PRIMO60	PRIMO72
12 lbs	14 lbs	18 lbs

WARNING! Risk of Injury! Glass is heavy. Use suction cups to handle glass.

Remove Barrier Glass - Clean Face Finish

1. Press glass suction cups firmly against glass to create a solid hold.
2. Slide glass straight up behind finishing material. See Figure 11.1.
3. Tilt bottom out as shown in Figure 11.1. Slide glass down to remove it from the appliance.
4. Set glass on prepared work surface.

Replacing Barrier Glass - Clean Face Finish

1. Press glass suction cups firmly against glass to create a solid hold.
2. Tilt glass and slide glass between finishing material and barrier glass tabs. See Figure 11.2.
3. Center the barrier glass left to right.
4. Tilt bottom in toward appliance. Set glass down into position on rubber bumpers.

NOTE: When barrier glass is installed, a vertical gap of approximately 3/8 inch is formed between the bottom of the glass and the transition media tray. This gap allows adequate air flow through the appliance.

CAUTION! Risk of Overheating! Vertical gap 3/8 inch required for proper airflow.

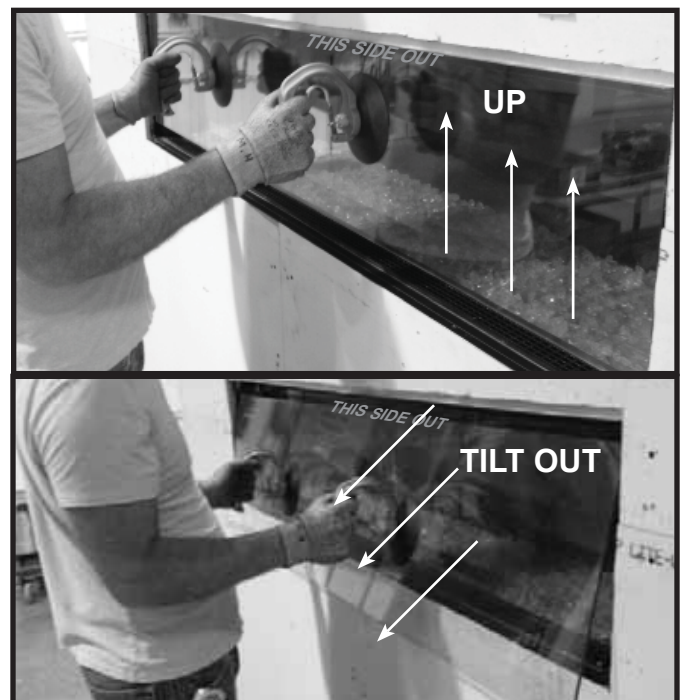

Figure 11.1. Barrier Glass - Clean Face Finish

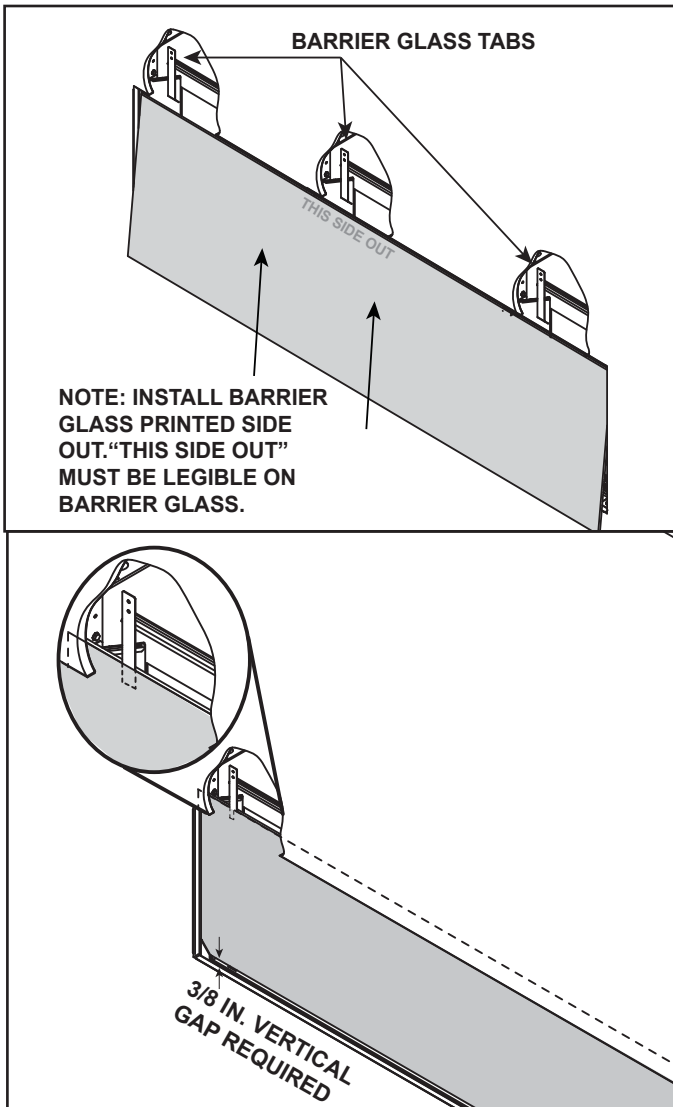

Figure 11.2. Replace Barrier Glass - Clean Face Finish
Removing Barrier Glass - Black Granite Finish

1. Slide side granite pieces inward toward center of fire-place to disengage from the key slots. See section 10.C.
2. Remove (unscrew) D-shaped retaining tabs.
3. The glass rests against the barrier glass support bracket. See Figure 11.4.
4. Use suction cups to remove barrier glass.
5. Rotate/tilt the bottom of the glass outward to remove. See Figure 11.4.
6. Set the glass on a prepared work surface.

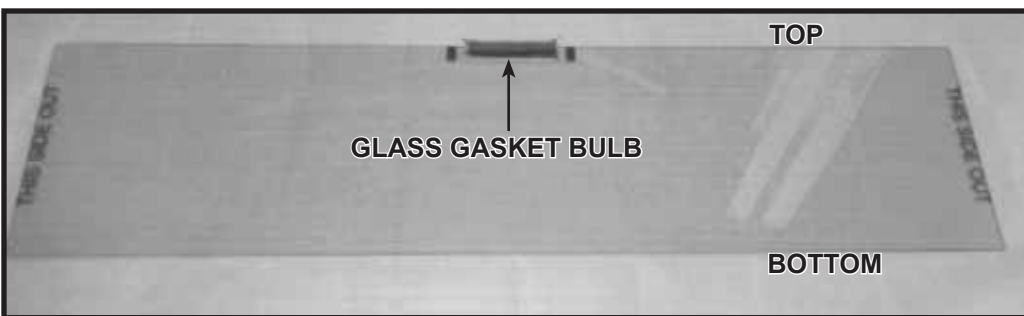

Figure 11.3 Glass Gasket Detail - Black Granite Finish

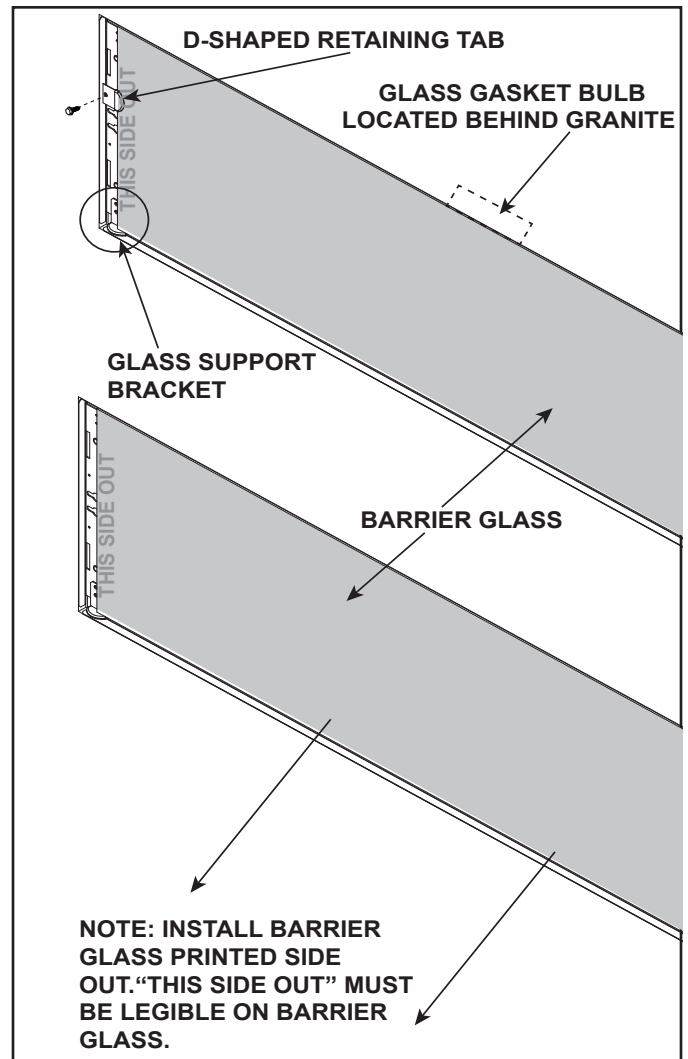

Figure 11.4 Barrier Glass - Black Granite Finish
Replacing Barrier Glass - Black Granite Finish

1. Use suction cups to pick up barrier glass.
2. Place the top edge of the barrier glass behind the top granite trim.

Note: Ensure the glass gasket is installed. The glass gasket bulb should be positioned on the outside surface of the barrier glass surround as shown in Figure 11.4. It is labeled "THIS SIDE OUT."

CAUTION! Risk of Injury! Glass gasket shall be installed on barrier glass! Hot glass will cause burns.

3. The glass rests against the barrier glass support bracket as shown in Figure 11.4.
4. Attach and tighten the D-shaped retaining tab. See Figure 11.4.

G. Firebox Glass Assembly

WARNING! Risk of Asphyxiation! Handle firebox glass assembly with care. Inspect the gasket to ensure it is undamaged and inspect the glass for cracks, chips or scratches.

CAUTION! Risk of Cuts! Wear protective gloves and safety glasses during installation. Use suction cups to handle firebox glass.

Note: If a granite surround is installed, the two side pieces need to be removed in order to access the firebox glass. See appliance installation manual.

- **PRIMO60 AND PRIMO72 MODELS:** It is recommended that glass installation and removal be performed by two qualified service technicians.

Removing Firebox Glass Assembly

1. Remove the transition media from the appliance. Lift the transition media tray out of appliance. The transition media tray fits tightly, lift carefully. See Figure 11.5.
2. Locate the glass clips that are on the upper edge of the glass frame of the appliance. See Figure 11.5.
3. Use both index fingers to release the glass clips.
4. Allow glass to tilt forward. Lift up and out. The glass will lift out of the bottom retaining lip.

Replacing Firebox Glass Assembly

1. Locate retaining lip on lower front face of firebox.

Note: Remove any media that may have fallen into the glass retaining lip.

2. Place glass assembly into retaining lip. Tilt top of glass assembly toward fireplace.
3. Assure proper left to right placement of glass and engage all four spring latches.

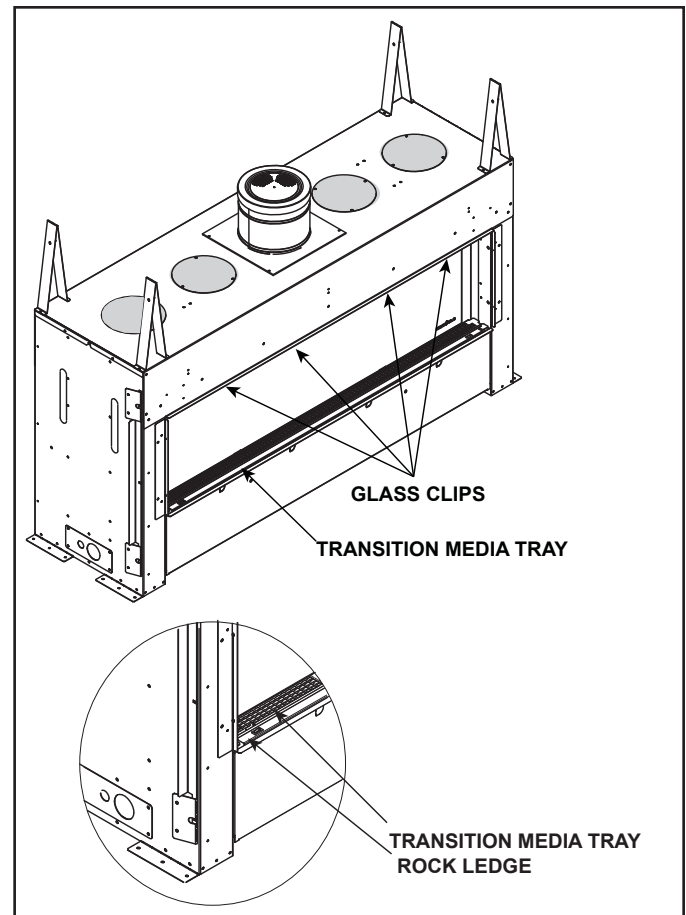

Figure 11.5 Location of Glass Clips and Transition Media Tray

Firebox Glass Weights		
PRIMO48	PRIMO60	PRIMO72
20.2 lbs	24.5 lbs	28.5 lbs

WARNING! Handle glass with care. Glass is breakable. Inspect the gasket to ensure it is undamaged and inspect the glass for cracks, chips or scratches.

- Avoid striking, scratching or slamming glass
- Avoid abrasive cleaners
- **DO NOT** clean glass while it is hot
- Replace as a complete assembly.
- Prepare a work area large enough to accommodate firebox glass assembly and barrier glass by placing a drop cloth on a flat, stable surface.

Note: Firebox glass assembly and gasketing may have residue that can stain carpeting or floor surfaces.

12 Reference Materials

A. Vent Components Diagrams

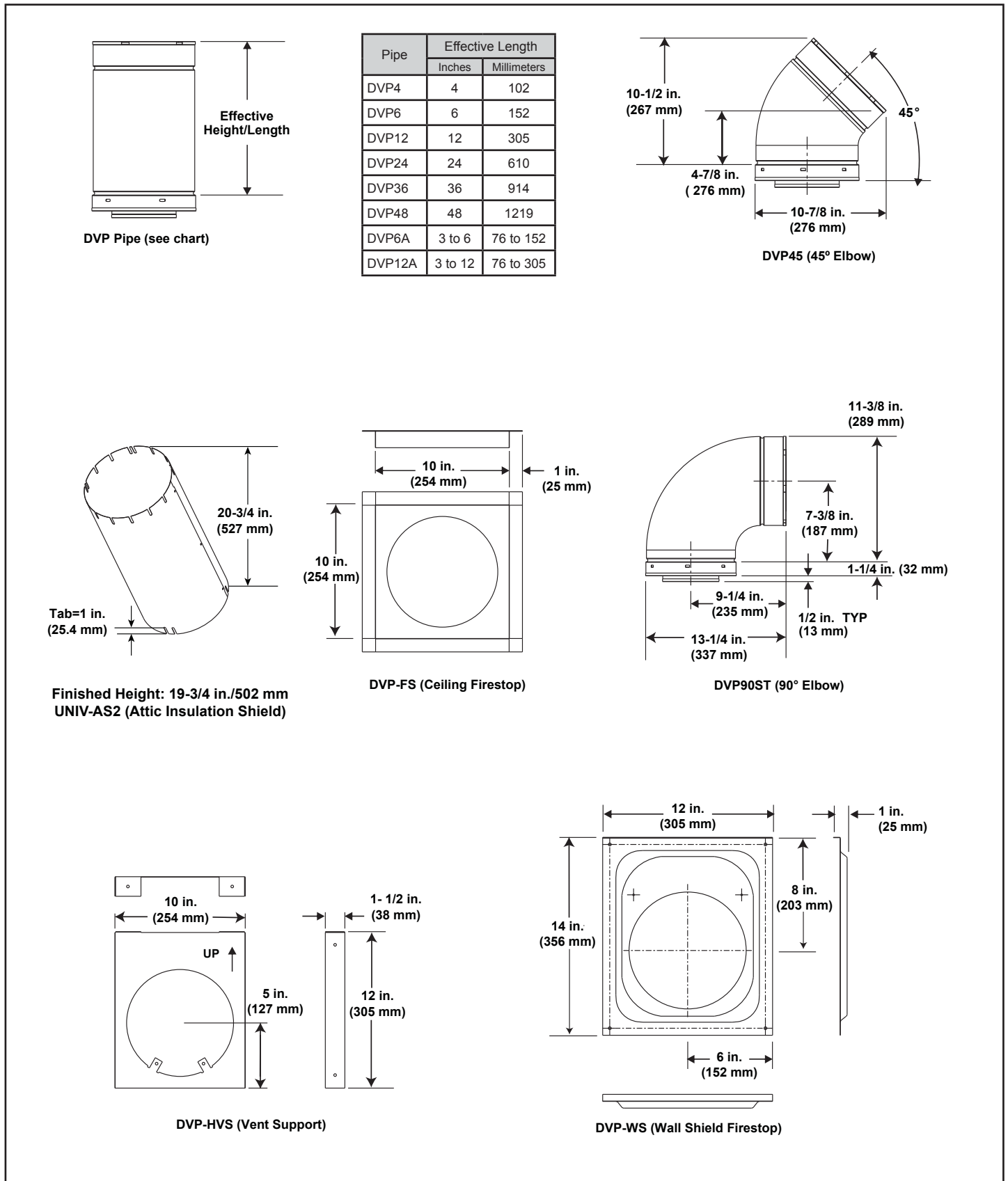
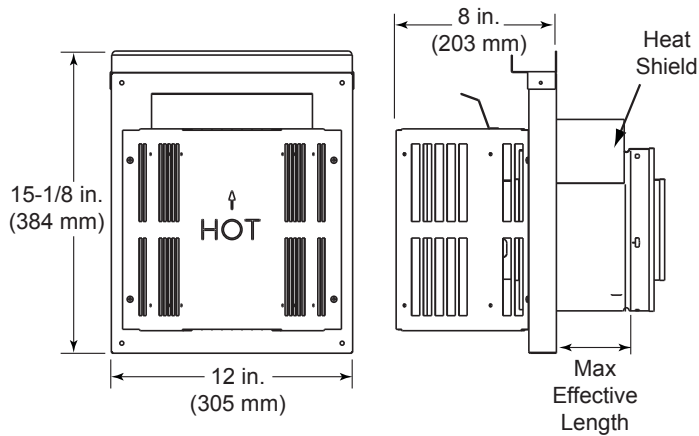

Figure 12.1 DVP Vent Components

Note: Heat shields **MUST** overlap by a minimum of 1-1/2 in. (38 mm). **The heat shield is designed to be used on a wall 4 in. to 7-1/4 in. (102 mm to 184 mm) thick.** If wall thickness is less than 4 in. (102 mm) the existing heat shields must be field trimmed. If wall thickness is greater than 7-1/4 in. (184 mm) a DVP-HSM-B will be required.



DVP-TRAP
Horizontal Termination Cap

Term Cap	Minimum Effective Length	Maximum Effective Length
Trap1	3-1/8 in.	4-5/8 in.
	79 mm	117 mm
Trap2	5-3/8 in.	9-3/8 in.
	137 mm	238 mm

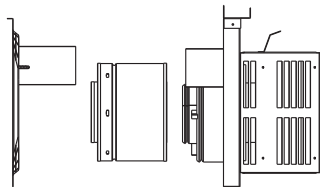

DVP-TRAP1

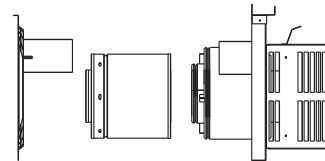

DVP-TRAP2

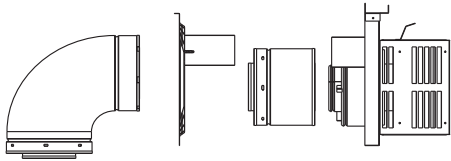

DVP-TRAPK1

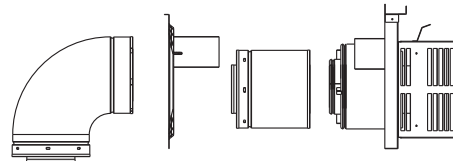

DVP-TRAPK2

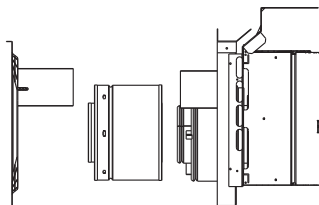

DVP-HPC1

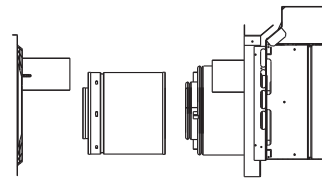

DVP-HPC2

Figure 12.2 DVP vent components

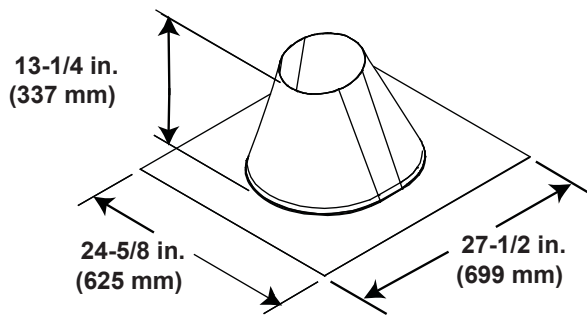

RF6
Roof Flashing

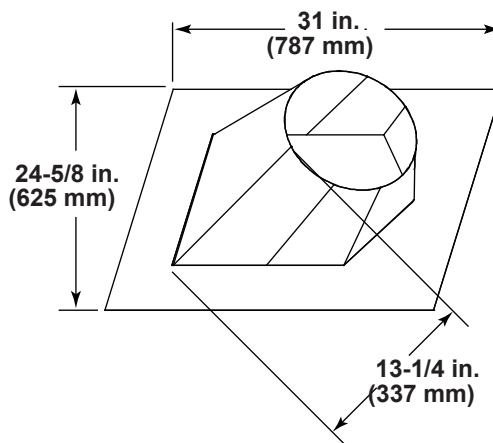

RF12
Roof Flashing

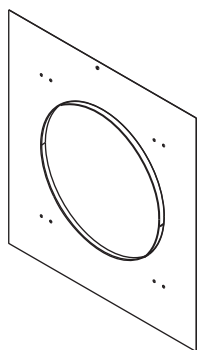

DVP-TRAPFL
Flashing

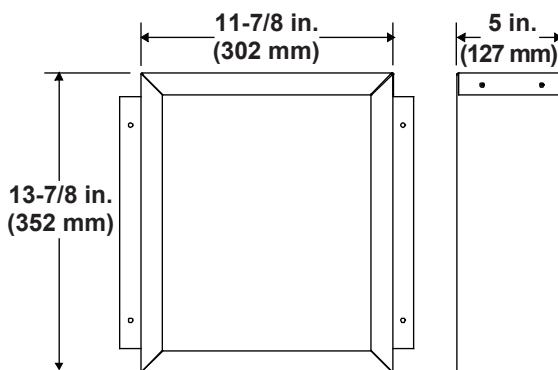

DVP-BEK2
DVP-HPC Cap Brick Extension

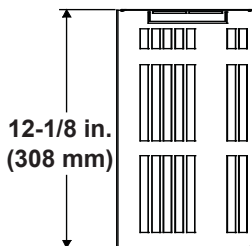
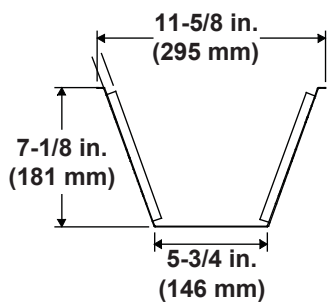

COOL-ADDM
Cap Shield

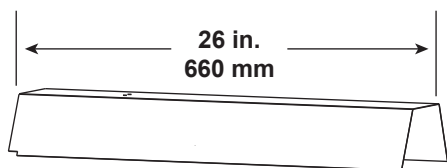
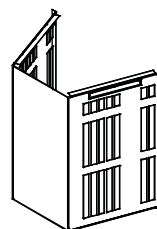

DVP-HSM-B
Extended Heat Shield

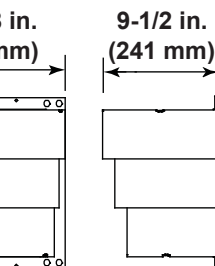
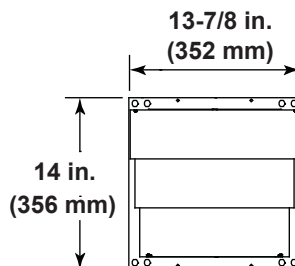

DRC-RADIUS
Cap Shield

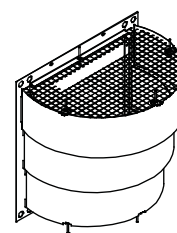

Figure 12.3 DVP Vent Components

A. Vent Components Diagrams (continued)

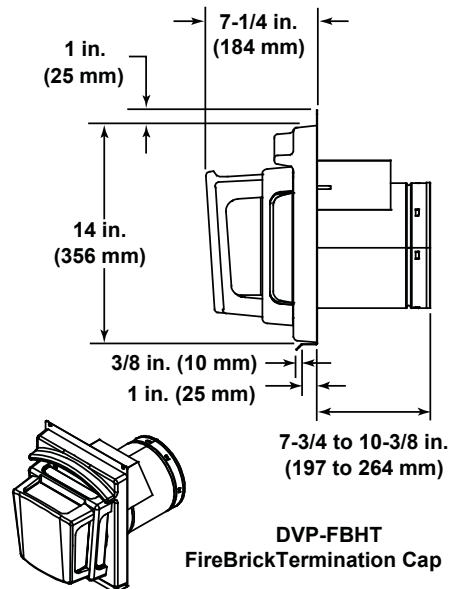
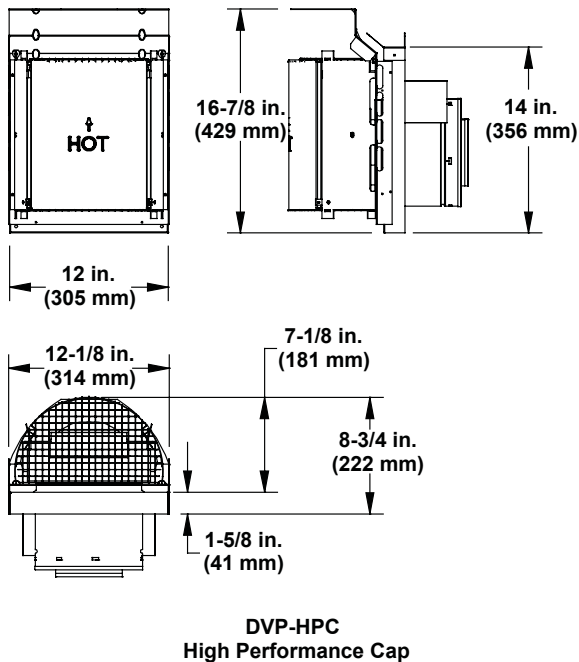
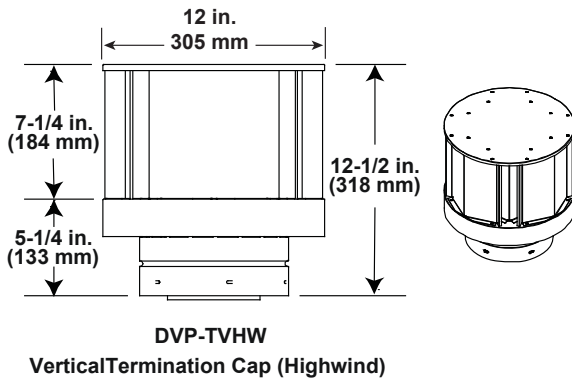
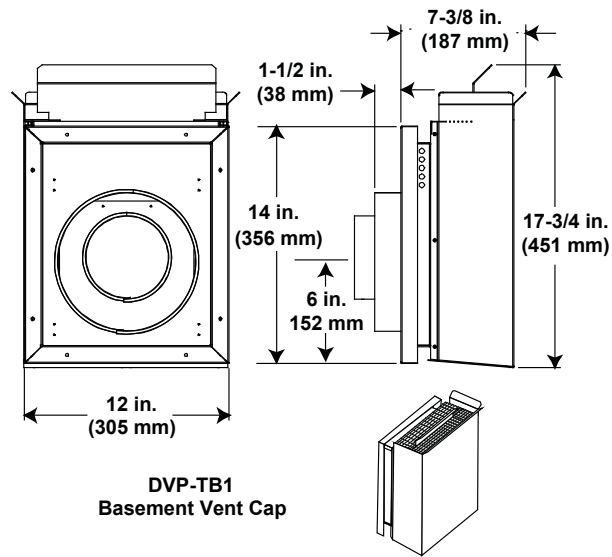
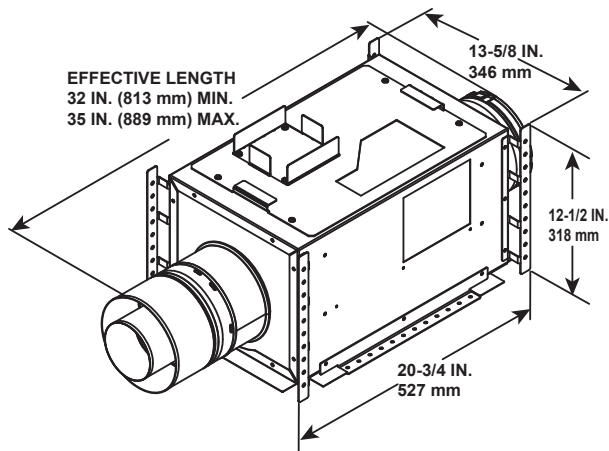

Figure 12.4 DVP Vent Components



PVI-SLP
Power Vent Inline

Optional Wire Harness	
DESCRIPTION	PART NUMBER
10 ft. PV Wire Harness	PVI-WH10
20 ft. PV Wire Harness	PVI-WH20
40 ft. PV Wire Harness	PVI-WH40
60 ft. PV Wire Harness	PVI-WH60
80 ft. PV Wire Harness	PVI-WH80
100 ft. PV Wire Harness	PVI-WH100

Note: Wire harnesses required to power the PVI-SLP connect to the appliance and are ordered separately from PVI-SLP. Contact your dealer to order.

Note: Termination caps listed in Section 12.A are approved for use with the PVI-SLP.

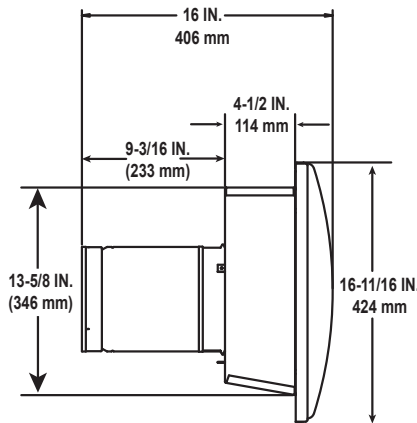
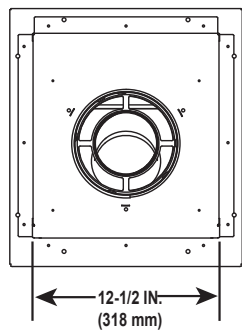

SLP-LPC
SLP Low Profile Cap

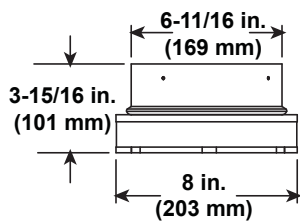
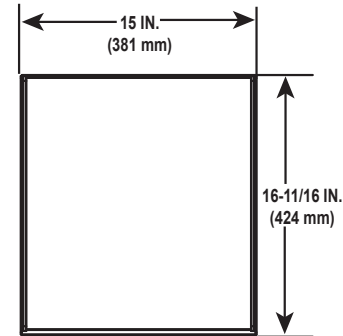

SL-2DVP
Adapter

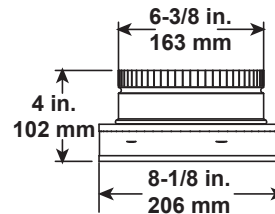
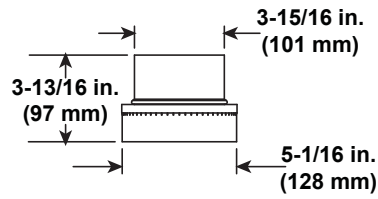

DVP-2SL
Adapter

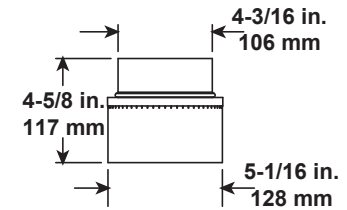
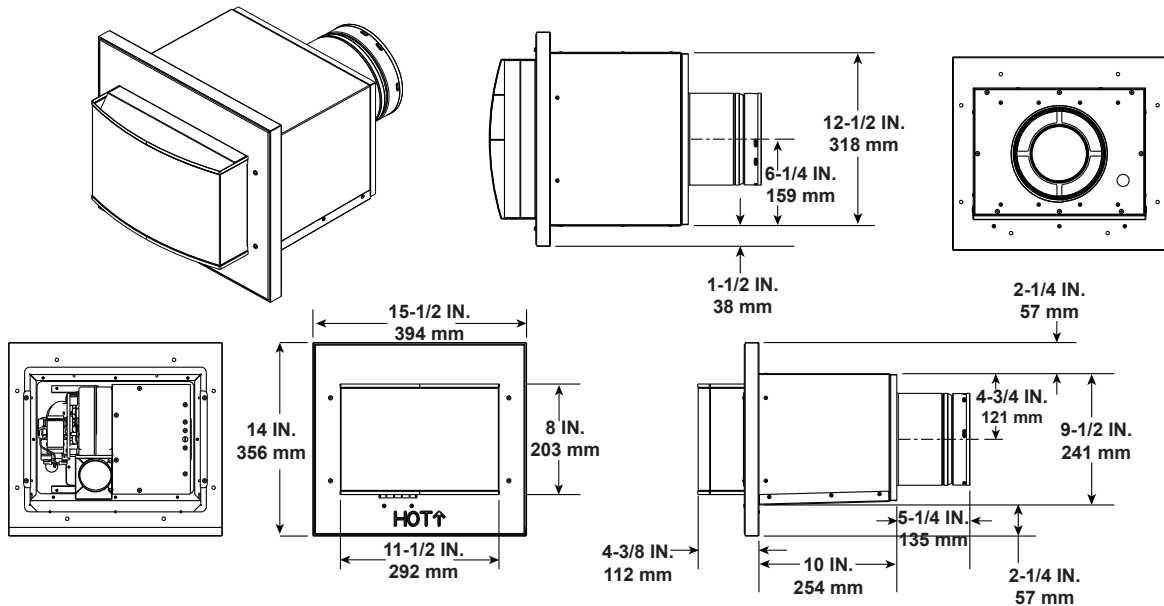

Figure 12.5 Vent Components

PVLP-SLP

Horizontally Terminated Power Vent



Optional Wire Harness	
DESCRIPTION	PART NUMBER
10 ft. PV Wire Harness	PVI-WH10
20 ft. PV Wire Harness	PVI-WH20
40 ft. PV Wire Harness	PVI-WH40
60 ft. PV Wire Harness	PVI-WH60
80 ft. PV Wire Harness	PVI-WH80
100 ft. PV Wire Harness	PVI-WH100

Note: Wire harnesses required to power the PVLP-SLP connect to the appliance and are ordered separately from PVLP-SLP. Contact your dealer to order.

Note: A PVLP-HS heat shield is available and sold separately. Use if the PVLP-SLP is installed in a high traffic area.

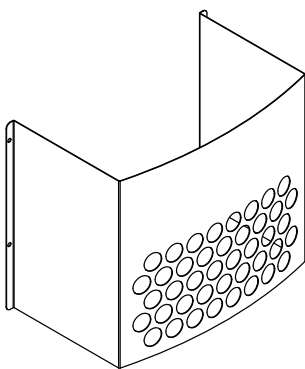

PVLP-HS
Heat Shield

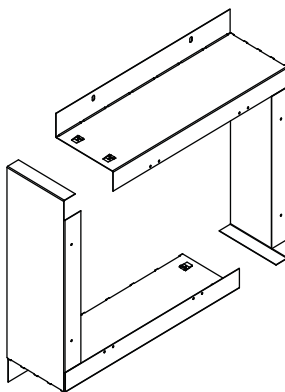

PVLP-BEK
Brick Kit

Figure 12.6 PVLP-SLP Power Vent Component

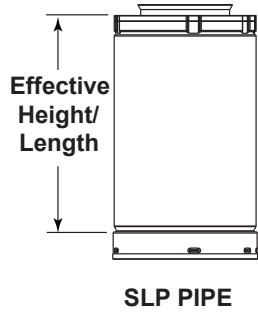
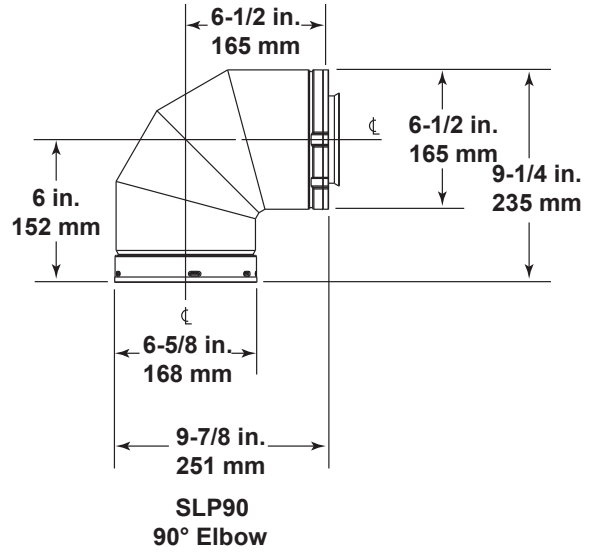
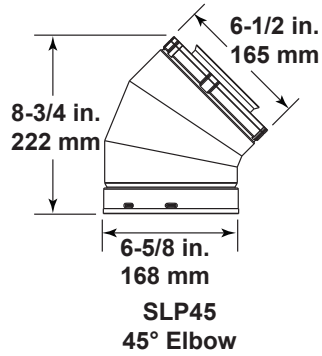

Effective Height/Length

Pipe	inches	mm
SLP4	4	102
SLP6	6	152
SLP12	12	305
SLP24	24	610
SLP36	36	914
SLP48	48	1219
SLP6A	2 - 6	51 - 152
SLP12A	2 - 12	51 - 305
SLP-FLEX-2	24	610
SLP-FLEX-3	36	914
SLP-FLEX-5	60	1524
SLP-FLEX-10	120	3048

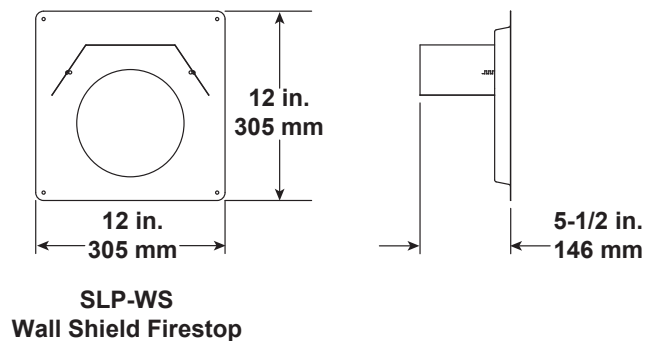
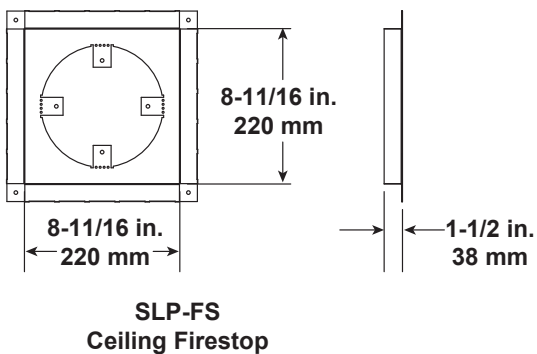
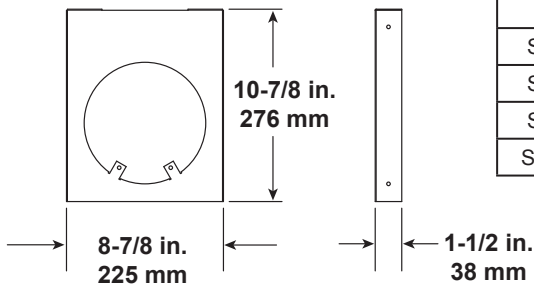
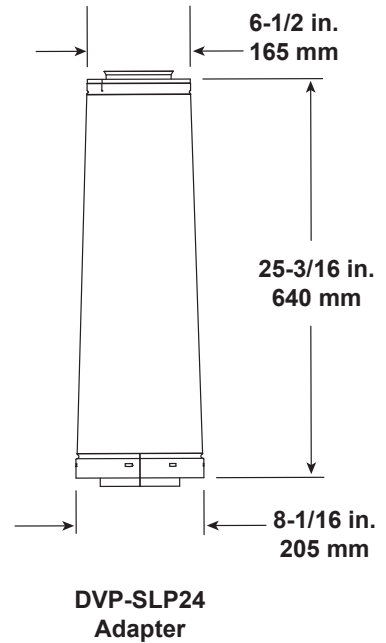
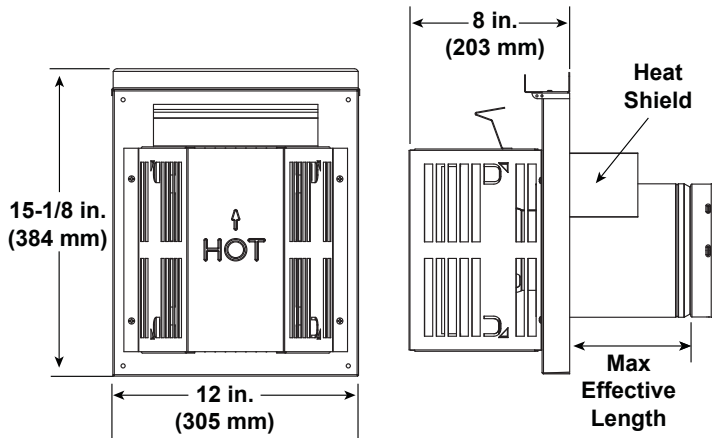

Figure 12.7 SLP Series Vent Components

Note: Heat shields MUST overlap by a minimum of 1-1/2 in. (38 mm). The heat shield is designed to be used on a wall 4 in. to 7-1/4 in. (102 mm to 184 mm) thick. If wall thickness is less than 4 in. (102 mm) the existing heat shields must be field trimmed. If wall thickness is greater than 7-1/4 in. (184 mm) a DVP-HSM-B will be required.



SLP-TRAP
Horizontal Termination Cap

Term Cap	Minimum Effective Length	Maximum Effective Length
Trap1	3-1/8 in.	4-3/4 in.
	79 mm	121 mm
Trap2	5-1/4 in.	9-1/4 in.
	133 mm	235 mm

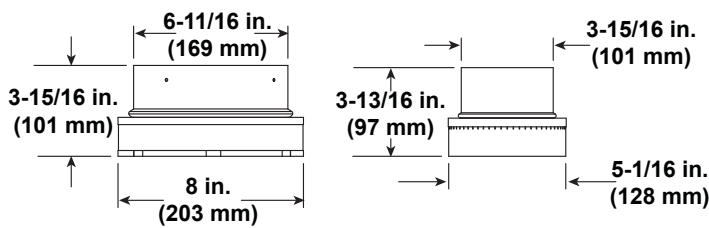

SL-2DVP
Adapter

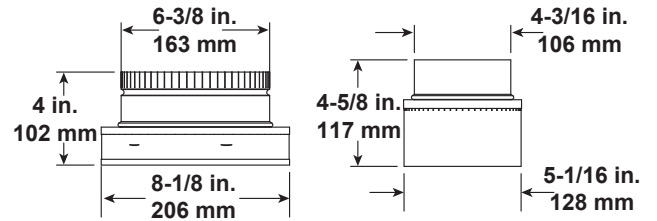

DVP-2SL
Adapter

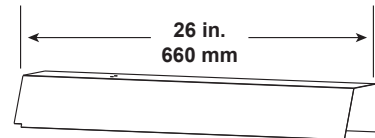

DVP-HSM-B
Extended Heat Shield

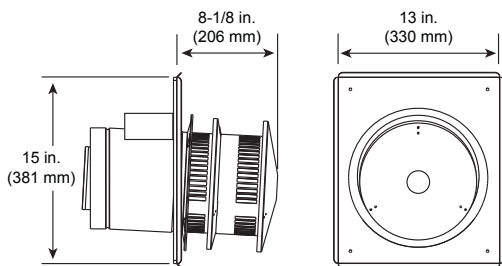

SLP-HRC-SS
Horizontal Termination Cap

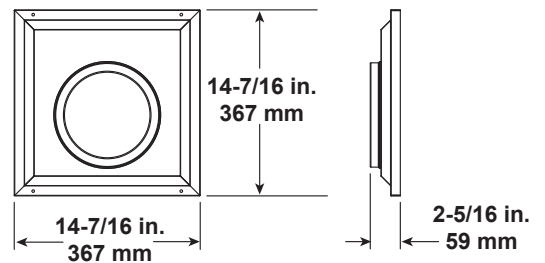

SLP-WT-BK
Wall Thimble-Black

Figure 12.8 SLP Series Vent Components

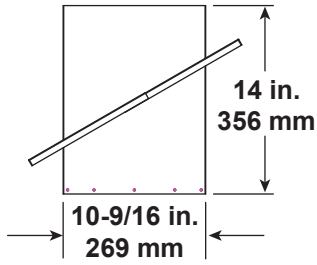

SLP-CCS-BK
Cathedral Ceiling
Support Box-Black

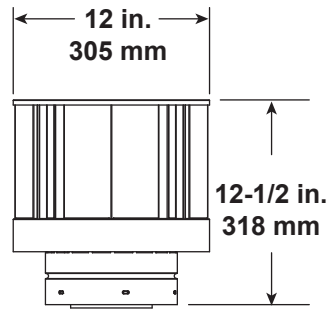

SLP-TVHW
Vertical
Termination Cap

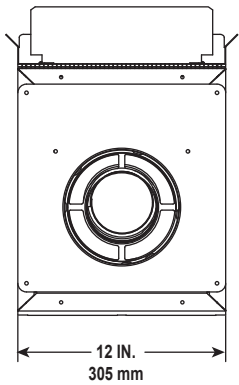

SLP-TB1
Basement Vent Cap

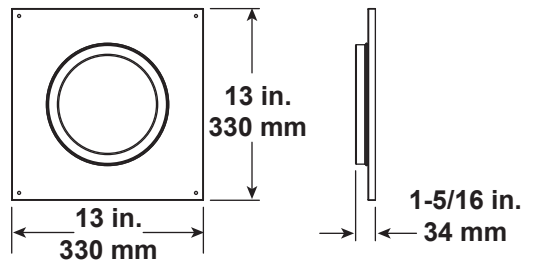
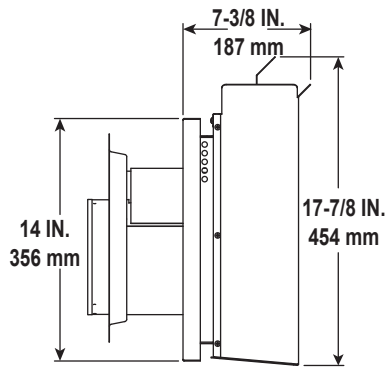

SLP-DCF-BK
Ceiling Firestop
Black

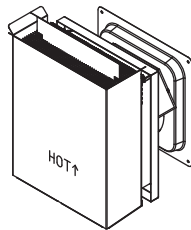

Figure 12.9 SLP Series Vent Components

B. Accessories

WARNING! Risk of Fire and Electric Shock! Use **ONLY** Hearth & Home Technologies-approved optional accessories with this appliance. Using non-listed accessories could result in a safety hazard and will void the warranty.

PowerFlow™ Heat Management System

After a qualified service technician has installed the appliance and the PowerFlow™ Heat Management System, follow the instructions included with the heat management system to operate it.

One or both of the following heat management systems must be installed:

HEAT-OUT-PRIMO: A heat management system in which the heat may be transferred outside the home/building.

HEAT-ZONE-PRIMO: A heat management system in which the heat can be transferred to another room with in the home/building.

For safety:

- Verify that the heat management fan(s) is not blocked or obstructed.
- Verify that the heat management fan(s) is operational.

Contact your dealer if you have questions.

Fire Art

Fire art accessories may be installed by a qualified service technician following the instructions included with the accessory.

Optional accessories include modern logs and multiple media options. Contact your dealer for details.

Finish Options

The PRIMO has two finishing options. Each option is explained in detail in Section 10.

Black Granite Surround (Black Granite Interior)

This option includes a four piece black granite surround and interior granite panels.

Clean Face Finish (Black Glass Interior)

This option includes interior black glass panels.

Heat & Glo, a brand of Hearth & Home Technologies
7571 215th Street West, Lakeville, MN 55044
www.heatnglo.com

Please contact your Heat & Glo dealer with any questions or concerns.
For the location of your nearest Heat & Glo dealer,
please visit www.heatnglo.com.

Printed in U.S.A. - Copyright 2015