



Tempest Torch Electronic Ignition

Owner's Manual

Natural Gas (sku 94900744) - Propane (sku 94900754)





ANSI Z21.97-2012/CSA 2.41-2012, CGA 2.17-M91 (R2009)
Outdoor Decorative Gas Appliances - Report # 028-F-83b-5

WARNING: For Outdoor Use Only

WARNING: If the information in this manual is not followed exactly, a fire or explosion may result causing property damage, personal injury or loss of life.

- Do not store or use gasoline or other flammable vapors and liquids in the vicinity of this or any other appliance.
- An LP cylinder not connected for use shall not be stored in the vicinity of this or any other appliance.
- Installation and service must be performed by a qualified installer, service agency or the gas supplier

| | |
|--|--|
|  DANGER | <p>CARBON MONOXIDE HAZARD</p> <p>This appliance can produce carbon monoxide which has no odor.</p> <p>Using it in an enclosed space can kill you.</p> <p>Never use this appliance in an enclosed space such as a camper, tent, car or home.</p> |
|  | |

DANGER

If you smell gas:

1. Shut off gas to the appliance.
2. Extinguish any open flame.
3. If odor continues, keep away from the appliance and Immediately call your gas supplier or fire department.

WARNING: Improper installation, adjustment, alteration, service or maintenance can cause injury or property damage. Read this manual thoroughly before installing or servicing this equipment. For assistance or additional information consult a qualified installer, service agency, or the gas supplier.

Installer: After installation give this manual to the homeowner and explain operation of this appliance.

\$10.00 © Copyright 2013, T.I. Part # 100-01231_000





Overview

This manual details the installation, operation, and routine maintenance for the Tempest torch.

Listing Details

This torch was tested to ANSI Z21.97-2012/CSA 2.41-2012, CGA 2.17-M91 (R2009) "Outdoor Decorative Gas Appliances".

| | | | | | | | | | | | | | | | | | | | | | | | | | | | | | | | | | | | | | |
|--|--|--|---|--------|--------|--------------|-----|-----|-------------------|----------|----------|-------------------|-------|--------|---------------------|-------|--------|---|--|-----------|-----------|--|--------|--------|--|-----|-----|--|----------|----------|--|-------|--------|--|-------|--------|-----------------------------------|
|  <p>TRAVIS INDUSTRIES HOUSE OF FIRE</p> <p>4800 Harbour Pointe Blvd. SW Mukilteo, WA 98275 tempesttorch.com</p> | <p>Tempest Torch (U.S. & Foreign Pat. Pending) Report Number: 028-G-83b-5</p> | <p>Tested & Listed By  Portland Oregon USA OMNI-Test Laboratories, Inc.</p> | Serial Number | | | | | | | | | | | | | | | | | | | | | | | | | | | | | | | | | | |
| | | | <div style="border: 1px solid black; height: 20px; width: 100%;"></div> | | | | | | | | | | | | | | | | | | | | | | | | | | | | | | | | | | |
| | <p><u>Min. Clearances to Combustible Materials*</u></p> <ul style="list-style-type: none"> • 26" from top of glass • 8" from side of glass • 2.5" from bottom of glass <p>*See manual for further details</p> | <p><u>Gas Rating</u></p> <table border="0"> <tr> <td>Input Rating (BTU/h)</td> <td>20,000</td> <td>20,000</td> </tr> <tr> <td>Orifice Size</td> <td>#50</td> <td>#55</td> </tr> <tr> <td>Burner Port Holes</td> <td>25 Holes</td> <td>49 Holes</td> </tr> <tr> <td>Manifold Pressure</td> <td>7" wc</td> <td>11" wc</td> </tr> <tr> <td>Max. Inlet Pressure</td> <td>7" wc</td> <td>11" wc</td> </tr> </table> | Input Rating (BTU/h) | 20,000 | 20,000 | Orifice Size | #50 | #55 | Burner Port Holes | 25 Holes | 49 Holes | Manifold Pressure | 7" wc | 11" wc | Max. Inlet Pressure | 7" wc | 11" wc | <table border="0"> <tr> <td></td> <td><u>NG</u></td> <td><u>LP</u></td> </tr> <tr> <td></td> <td>20,000</td> <td>20,000</td> </tr> <tr> <td></td> <td>#50</td> <td>#55</td> </tr> <tr> <td></td> <td>25 Holes</td> <td>49 Holes</td> </tr> <tr> <td></td> <td>7" wc</td> <td>11" wc</td> </tr> <tr> <td></td> <td>7" wc</td> <td>11" wc</td> </tr> </table> | | <u>NG</u> | <u>LP</u> | | 20,000 | 20,000 | | #50 | #55 | | 25 Holes | 49 Holes | | 7" wc | 11" wc | | 7" wc | 11" wc | <p>Pull Here For Label</p> |
| Input Rating (BTU/h) | 20,000 | 20,000 | | | | | | | | | | | | | | | | | | | | | | | | | | | | | | | | | | | |
| Orifice Size | #50 | #55 | | | | | | | | | | | | | | | | | | | | | | | | | | | | | | | | | | | |
| Burner Port Holes | 25 Holes | 49 Holes | | | | | | | | | | | | | | | | | | | | | | | | | | | | | | | | | | | |
| Manifold Pressure | 7" wc | 11" wc | | | | | | | | | | | | | | | | | | | | | | | | | | | | | | | | | | | |
| Max. Inlet Pressure | 7" wc | 11" wc | | | | | | | | | | | | | | | | | | | | | | | | | | | | | | | | | | | |
| | <u>NG</u> | <u>LP</u> | | | | | | | | | | | | | | | | | | | | | | | | | | | | | | | | | | | |
| | 20,000 | 20,000 | | | | | | | | | | | | | | | | | | | | | | | | | | | | | | | | | | | |
| | #50 | #55 | | | | | | | | | | | | | | | | | | | | | | | | | | | | | | | | | | | |
| | 25 Holes | 49 Holes | | | | | | | | | | | | | | | | | | | | | | | | | | | | | | | | | | | |
| | 7" wc | 11" wc | | | | | | | | | | | | | | | | | | | | | | | | | | | | | | | | | | | |
| | 7" wc | 11" wc | | | | | | | | | | | | | | | | | | | | | | | | | | | | | | | | | | | |
| <p><small>Tested to: Applicable portions of ANSI Z21.97-2012 / CSA 2.41-2012, CGA 2.17-M91 (R2009) "Outdoor Decorative Gas Fireplace", and AGA 8-96-1997, "Requirement for Gas-Fired Decorative Illuminating Appliances for Outdoor Installation". Suitable for use in elevations of 0-4500 ft (0-1370 m). Electrical Rating: 115 V, 60 Hz, 0.5 Amps</small></p> <p><small>For outdoor installation only. If stored indoors, detach and leave cylinder outdoors (if applicable). The gas supply must be turned off at the LP-gas supply cylinder when this appliance is not in use (if applicable).</small></p> <p><small>CAUTION: When using an LP cylinder, the gas pressure regulator provided with the post and base kit must be used. The regulator is set for an outlet pressure of 11" wc for LP.</small></p> <p><small>FOR YOUR SAFETY: Do not store or use gasoline or other flammable vapors and liquids in the vicinity of this or any other appliance.</small></p> <p><small>WARNING: Improper installation, adjustment, alteration, service or maintenance can cause injury or property damage. Refer to the owner's information manual provided with this appliance. For assistance or additional information consult a qualified installer, service agency or the gas supplier.</small></p> | | | 0930 | | | | | | | | | | | | | | | | | | | | | | | | | | | | | | | | | | |

Important Registration and Service Information

No other Tempest torch has the same serial number as yours. The serial number is on the safety label attached by a chain near the control panel. This serial number will be needed in case you require service of any type. To receive full warranty coverage, you will need to show evidence of the date of purchase. Mail your warranty card or visit traviswarranty.com to register your Tempest torch. If any service issues may arise, contact your dealer for details.

Introduction

Overview 2
Listing Details..... 2
Important Registration and Service Information .. 2

Safety Precautions

Safety Precautions 4

Features & Specifications

Features 5
Installation Options 5
Specifications 5
Dimensions 5

Installation

Installation Warnings..... 6
Packing List..... 6
Additional Items Required 6
Recommended Order of Installation 7
Placement Requirements..... 8
Gas Line Requirements 9
Gas Line Connection 9
Electrical Connection Requirements 9
Wiring Diagram 9
Wiring Multiple Torches to One Switch 10
Steps for Connecting the Electrical Line 11
Post Mount and Control Cover Installation..... 12
Torch Assembly 13
Optional Rain Cap..... 14
Wall Mount Kit..... 15
Post or Pier Mounted Torch 16

Operation

Before You Begin..... 17
Operating Instructions 17

Maintenance

Maintaining Your Torch 18
Winterizing The Torch..... 18
Replacement Parts 19
Troubleshooting Table 20

Warranty

Warranty 21

Index

Index 22

- ! **This appliance must be installed in accordance with all local codes, if any; if not, follow ANSI Z223.1.**
- ! **This appliance must only be used outdoors in a well-ventilated area. It may not be used in a building, garage, or other enclosed space.**
 - This appliance is not for use with solid fuel.
 - The torch must be kept clean and free of leaves and debris to insure safe operation.
 - Any hose or gas-supply line that is damaged or shows evidence of excessive abrasion or wear must be replaced prior to use of the torch.
 - If using a gas supply line to the torch, make sure it is properly located away from any walkway or in an area where it may be subject to accidental damage
 - Educate all children and adults of the dangers of the torch. Young children should be supervised when they are in the same area as the torch. Do not let children play with the torch.
 - Do not place clothing or other flammable items on or near the torch.
 - Any screen or guard removed for servicing must be replaced prior to operating the torch.
 - This unit must be installed and repaired by a qualified installer to prevent the possibility of an explosion. Your dealer will know the requirements in your area and can inform you of those people considered qualified. The torch should be inspected before use and at least annually by a qualified service person. More frequent cleaning may be required due to excessive debris from leaves, dirt, insects, etc.
 - Do not use this appliance if any part has been under water. Immediately call a qualified service technician to inspect the appliance and to replace any part of the control system and any gas control that has been under water.
 - The instructions in this manual must be strictly adhered to. Do not use makeshift methods or compromise in the installation. Improper installation will void the warranty and safety listing.
 - This appliance is approved for either natural gas (NG) or propane (LP). Burning the incorrect fuel will void the warranty and safety listing and may cause an extreme safety hazard. Direct questions about the type of fuel used to your dealer. A label is placed on the control panel to show which fuel the torch is designed for (in addition, NG units have 25 burner holes, LP units have 49 burner holes).
 - Contact your local building officials to obtain a permit and information on any installation restrictions or inspection requirements in your area.
 - If the flame becomes sooty, dark orange in color, or extremely tall, do not operate the torch. Call your dealer and arrange for proper servicing.
 - Do not operate the torch if it is not operating properly in any fashion or if you are uncertain. Call your dealer for a full explanation of your torch and what to expect.
 - Do not store or use gasoline or other flammable liquids in the vicinity of this torch.
 - Never remove, replace, modify or substitute any part of the torch unless instructions are given in this manual for routine maintenance and cleaning. A trained technician must do all other work. Do not modify or replace orifices.
 - Allow the torch to cool before carrying out any maintenance or cleaning.
 - Operate the torch according to the instructions included in this manual.
 - If the burner does not start correctly turn the gas off at the gas control valve and call your dealer for service.
 - Do not use this appliance to cook food.
 - Instruct everyone in the house how to shut gas off to the torch and at the gas main shutoff valve. The gas main shutoff valve is usually next to the gas meter or propane tank and requires a wrench to shut off.
 - Do not operate the torch during a lightning storm or a possible lightning storm.
 - Do not operate the torch during high wind conditions.
 - Do not install in or on recreational vehicles and/or boats.
 - Do not throw this manual away. This manual has important operating and maintenance instructions that you will need at a later time. Always follow the instructions in this manual.
 - **Travis Industries, Inc. grants no warranty, implied or stated, for the installation or maintenance of your torch, and assumes no responsibility of any consequential damage(s).**

Features:

- Electronic Ignition (switch turns torch on or off)
- Maximum 20,000 BTU Input
- Removable Rain Cap
- Tempered Glass (easy to remove and clean)
- Stainless Steel Construction
- Automatic Gas Shutoff Valve for Safety

Installation Options:

- For Outdoor Installation Only
- For Fixed Line Installations Only
- Wall Mount
- Post Mount
- Pier Mount

Gas Specifications:

| | NG | LP |
|---------------------|----------|----------|
| Input Rating (Btuh) | 20,000 | 20,000 |
| Orifice Size (DMS) | #50 | #55 |
| Burner Ports | 25 Holes | 49 Holes |
| Manifold Pressure | 7" wc | 11" wc |
| Max. Inlet Pressure | 7" wc | 11" wc |

Electrical Specifications:

120 Volts, 0.5 Amps (on startup), 60 watts (on startup)

Dimensions:

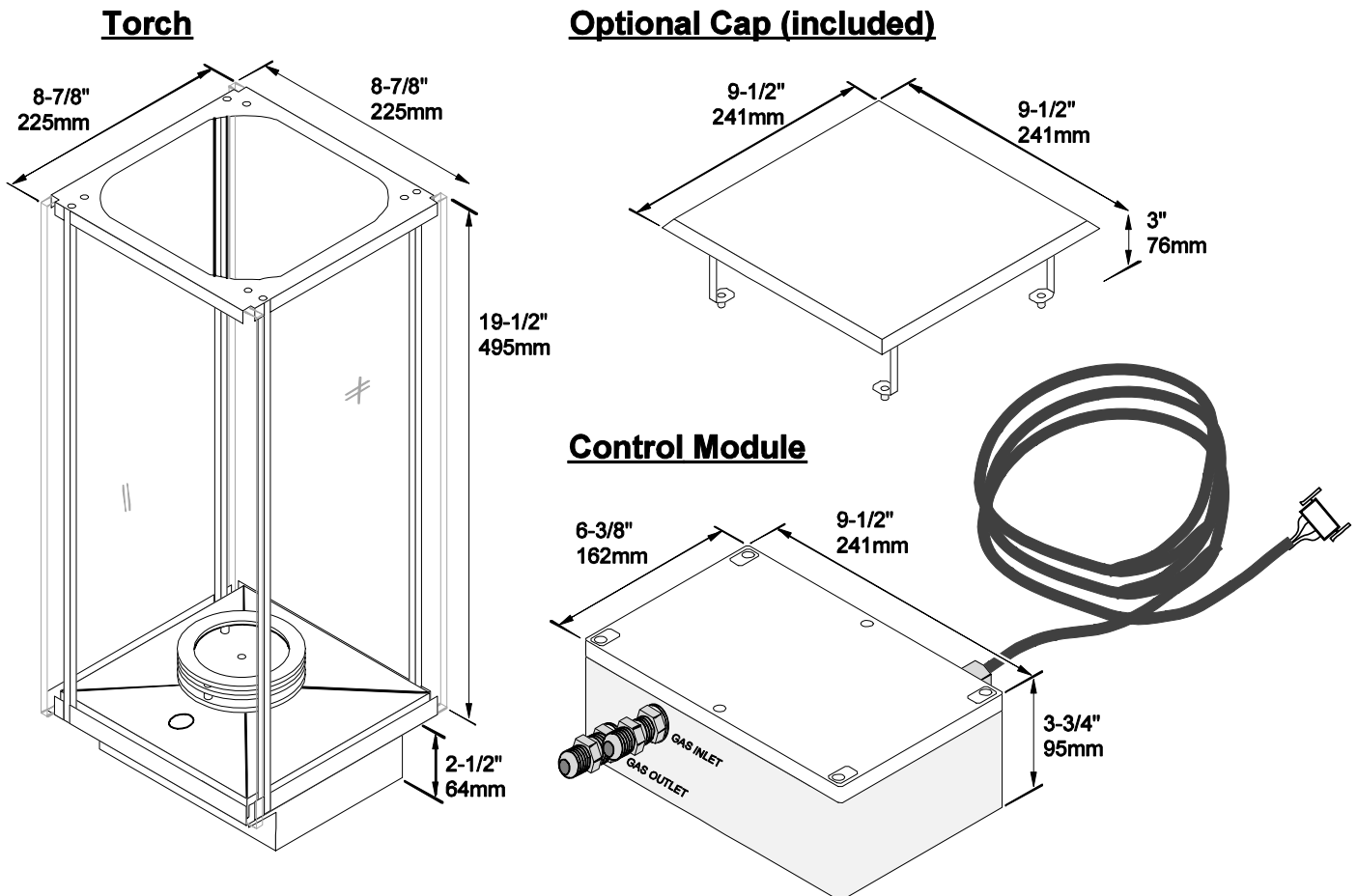

NOTE: All Clearances are measured from the glass (and glass frame).

Installation Warnings:

- ! This appliance is designed for outdoor use only, in well-ventilated areas.
- ! Failure to follow all of the requirements may result in property damage, bodily injury, or even death.
- ! This torch must be installed by a qualified installer.
- ! This appliance is designed to operate on natural gas, or propane (LP).
- ! This appliance requires a switched, 110 volt, GFCI (ground-fault interrupt circuit) protected power supply for operation.
- ! Notify your insurance company before hooking up this appliance. All relevant information on the Tempest Torch is located on page 2, *Important Information*. You can fax them page 2.
- ! The requirements listed below are divided into sections. All requirements must be met simultaneously. The order of installation is not rigid – the qualified installer should follow the procedure best suited for the installation.

Packing List

- Main Assembly
- Burner Top
- (4) Support Bars (w screws)
- Top Plate
- Rain Cap
- 5/32" Hex Wrench
- Control Cover (pre-installed)
- (4) ¼-20 x ½" Hex Head Screws
- Control Module with 12' Lead
- 12" Long ½" Flex Tube with Shutoff Valve (accepts ½" MPT)
- (4) #6 x 1" Screws (used to secure control module to wall or other structure)
- Glass (4 Pieces)
- Switch Label (place this label on the electrical switch to ease identification)
- 3/8" – ½" Flare Reducing Coupler (100-05144)

Additional Items Required

This Torch Requires One of the Following Base Assemblies:

- Wall Mount Kit
- Post Mounting Kit
- Pier Mounting Kit
- Gas Line from Control Module to Torch Head (1/2" Flex Tube Connections – maximum 12' long).

Recommended Order of Installation

1. Determine the location of torch. Make sure all clearances are met, (see page 8).
2. Determine the location of the control module. It must be located within 12' of the torch to allow connection of the low voltage wire harness. The control module may be mounted in any orientation. It may be located inside the structure, outside the structure, above or below ground level. The control module must be shielded from direct rain and if placed below ground, enclosed in an access box and protected from accidental damage from shovels or digging. Drainage must be provided for below ground installations to prevent the control module from becoming submerged in heavy rain or flood prone areas. Access to service the control module must be provided. See page 15 and 16 for example installations.
3. With the torch head and control module locations identified, prepare and mount the torch head support (pillar, post, or wall mount) and the control module. This order of installation may need to be modified due to individual installation conditions. NOTE: sections 4, 5, 6 and 7 of this page detail gas and electrical connections to the control module and between the control module and torch head.
4. **GAS SUPPLY:** The control module requires 20,000 BTU input (natural gas or LP). A shut off valve and 12 inches of flex line are provided to assist connection from the supply line to the control module. The shutoff valve accepts ½" MPT (male pipe thread). Before turning gas on to the module, leak-test all gas line connections.
5. **ELECTRICAL SUPPLY:** The electrical line must be GFCI (ground fault circuit interrupt) protected. The circuit must be routed through a switch to turn the torch on and off (see page 9). Multiple torches may be placed on a single circuit. Each torch uses approximately 0.5 amps - make sure the circuit and wiring is appropriately sized. Rout the electrical cable through the liquid-tight cord grip fitting on the side of the control module labeled "electrical in" and wire nut to the labeled power hookups inside (see page 11). If multiple torches are powered through a single switch, the control modules for each of the individual torches may be daisy-chained together using NEMA 4X liquid tight cord grips to pass the outgoing 115VAC power to the next torch installation.
6. Route the low voltage wire harness (attached to the control module) to the torch head location. Make sure to allow for enough slack on the line so it can be connected to the head when mounted. We recommend leaving the cable loose until after the torch head has been installed (step 8 below). Then remove slack from the cable and coil the extra harness length and secure . **THERE ARE SPECIFIC VOLTAGE AND RESISTANCE REQUIRMENTS FOR THE HOT WIRE IGNITER ANDTHE SUPPLIED WIRE HARNESS MAY NOT BE CUT OR LENGTHENED.** When using the Travis wall mount kit, pass the wire harness through the attaching wall directly under the gas supply line. There is a cut out provided in the wall mount kit mounting plate that will allow the wire harness to be routed along the underside of the gas line supply line and through the wall mount kit to the torch head.
7. For outside post and pillar installations route a ½" stainless steel flexible gas line from the control module "GAS OUT" connection to the torch head. A male ½" 45 degree flare fitting is provide at the control module and the torch head for this connection (you will have to provide this gas line). For wall mount applications; if using flex line to pass through the wall of a building the flex line must be enclosed in conduit for protection, or local code may require you to hard pipe the connection from the control module to the torch head.
8. Attach the torch head to the mount (wall or post mount – see page 12 or the wall mount instructions). Attach the gas line. Attach the low voltage wire harness. Leave the control covers loose to allow for leak testing access. Install the torch assembly (see page 13).
9. Bleed the gas line and start the torch by switching on the electrical power to the control module. Leak test the gas lines. Verify the torch works correctly and there are no gas leaks. Attach the control covers.
10. Give the manual to the home owner and explain the operation of the torch.

Placement Requirements

! For Outdoor Use Only. Install in well-ventilated areas.

Do Not Locate the Torch:

- In high traffic areas.
- Under or near trees, plants and buildings where debris may constantly fall into the torch. Excessive debris will require high maintenance and/or cause malfunctioning of the torch.
- In places where people, children, and pets may contact the torch. Guards or fences around the torch in these locations are recommended.
- In places where the controls beneath the torch may be submerged under water. Submerging of any part of its controls may require complete replacement of the controls.

Clearances:

- The distance from ground level to the base of the burner shall be a minimum of 7 ft. (2.1M) where installed within 2 feet (0.6M) of public walkways (e.g.: sidewalk, shared walkway between two homes, or pathway in commercial applications). Lesser clearances shall be permitted to be used only where acceptable to the authority having jurisdiction.
- Keep combustibles away from the shaded heat zone of the torch (see illustration below).

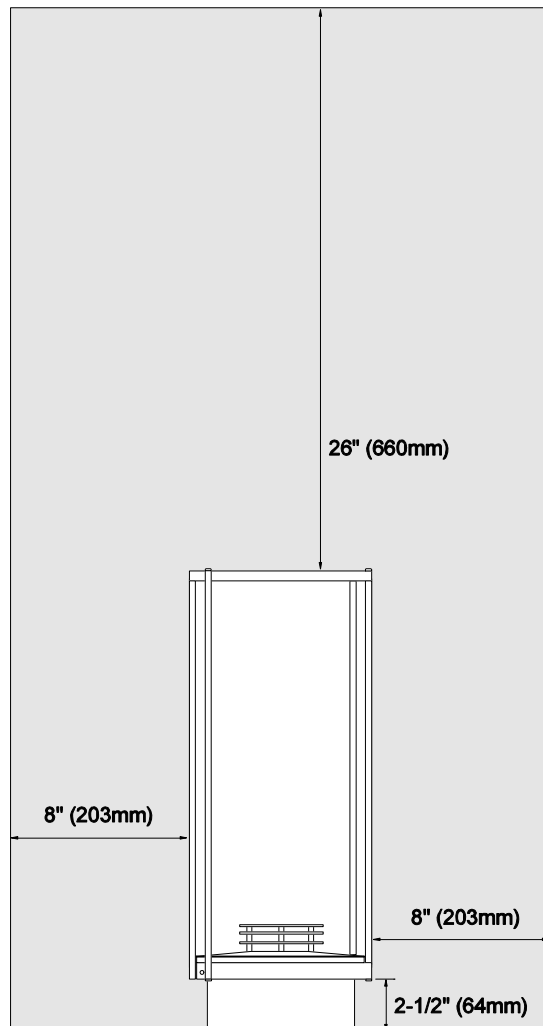

Gas Line Requirements

MASSACHUSETTS INSTALLATIONS - **WARNING:**

THIS PRODUCT MUST BE INSTALLED BY A LICENSED PLUMBER OR GAS FITTER WHEN INSTALLED WITHIN THE COMMONWEALTH OF MASSACHUSETTS.

OTHER MASSACHUSETTS CODE REQUIREMENTS:

- Flexible connector must not be longer than 36 inches.
- Shutoff valve must be a "T" handle gas cock.
- Only direct vent sealed combustion products are approved for bedrooms or bathrooms.
- Fireplace dampers must be removed or welded in the open position prior to the installation of a fireplace insert or gas log.
- A carbon monoxide (CO) detector is required in the same room as the appliance.

! The gas line must be installed in accordance with all local codes or, in the absence of local codes, with the National Fuel Gas Code, ANSI Z223.1/NFPA 54, International Fuel Gas Code, Natural Gas and Propane Installation Code, CSA B149.1, or Propane Storage and Handling Code, B149.2, as applicable. Consult your local gas supplier or propane gas dealer for code regulations and recommended procedures.

! The torch and gas control module must be disconnected from the gas supply piping during any pressure testing of that system at test pressures in excess of 1/2 psig. For pressures less than 1/2 psig, isolate the gas supply piping by closing the manual shut-off valve.

! Leak test all gas line joints and the gas control valve prior to and after starting the torch.

LP and NG Configuration

This torch is shipped either for natural gas or for propane. **The torch is not convertible from one fuel to another.** Check the sticker on the control panel to make sure the correct fuel is used. The torch has unique orifices and burners for each fuel. See the table below for details.

| | NG | LP |
|---------------------|----------|----------|
| Input Rating (Btuh) | 20,000 | 20,000 |
| Orifice Size (DMS) | #50 | #55 |
| Burner Ports | 25 Holes | 49 Holes |
| Manifold Pressure | 7" wc | 11" wc |
| Max. Inlet Pressure | 7" wc | 11" wc |

Gas Line Connection

A manual shutoff valve is required on the gas supply to the torch. It should be placed upstream of the control module. A shut-off valve is included with the torch.

Electrical Connection Requirements

- ! The appliance, when installed, must be electrically grounded in accordance with local codes, or in the absence of local codes with the National Electrical Code, ANSI/NFPA 70; or the Canadian Electrical Code, CSA C22.1
- ! The electrical line must be installed by a qualified installer and must meet all local codes. Consult your local building official for code regulations and recommended procedures.
- ! The control module electrical line must be protected by a GFCI (ground fault circuit interrupt).
- ! Use dielectric grease on the 120volt connection (wire nuts) to prevent corrosion.

Wiring Diagram

Supplied fitting accepts 14/2 or 12/2 electrical line.

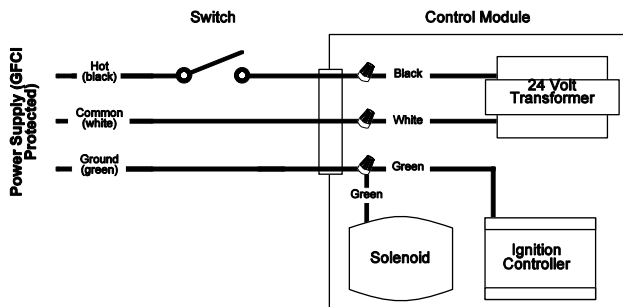

10 Installation (for qualified installers only)

Wiring Multiple Torches to One Switch

Multiple torches may be wired to a single switch. The torches are wired in parallel (see diagram below). Each torch uses 0.5 amps – make sure the circuit and wire are sized appropriately.

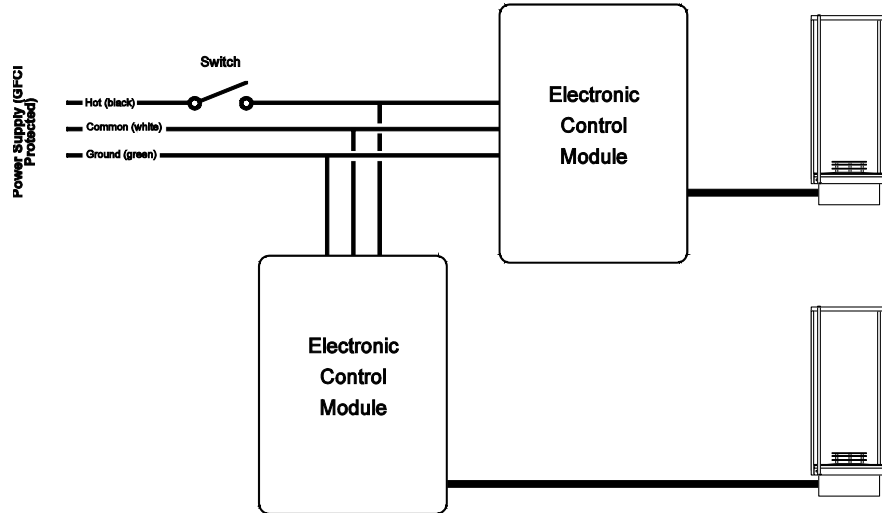

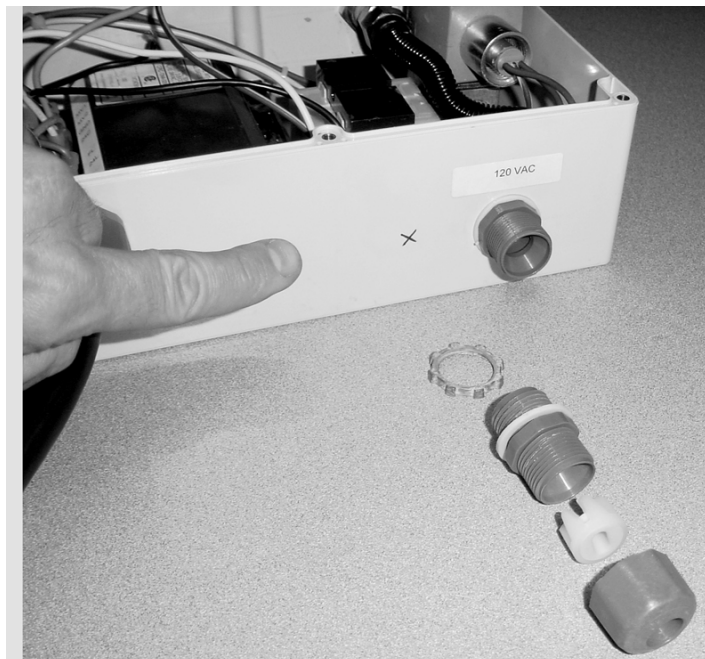

Wiring Multiple Torches in Daisy-Chain Configuration

The control module is sealed and may be used as a junction box to daisy chain one control module to another. This is especially useful when the torches are a long distance from the switch. To make an additional pass-through in the box, use a NEMA 4X liquid-tight cord grip (clamp). Drill the appropriate sized hole in the control module housing near the electric input location, making sure to not damage any internal components (see the "x" in the photo below). Remove all drill debris.

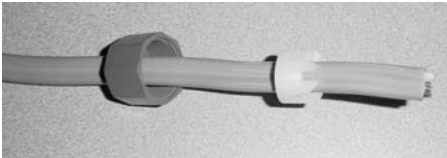
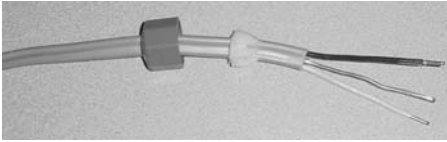
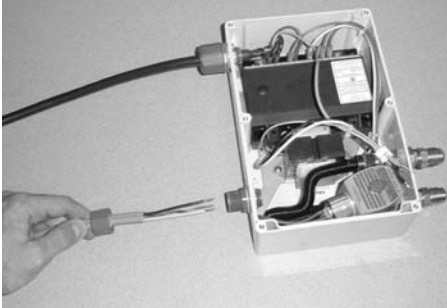

Steps for Connecting the Electrical Line

The electrical line is routed through a water-resistant connection and attached to the electrical leads inside the control module as shown below.

| | |
|---|--|
| <p>Remove the cover from the control module. Remove the connector sleeve and securing nut from the control module.</p> |  |
| <p>Slide the sleeve and securing nut over the end of the electrical line. NOTE: Supplied fitting accepts 14/2 or 12/2 electrical line.</p> |  |
| <p>Remove approximately 3" of out sheathing from the electrical line. Expose approximately 3/8" of wire for the electrical connection.</p> |  |
| <p>Route the electrical line into control module.</p> |  |
| <p>Re-attach the connector sleeve and securing nut, making sure an air-tight seal is maintained.</p> |  |
| <p>Use three wire nuts to secure the electrical lines.</p> <p>! Use dielectric grease on the 120volt connection (wire nuts) to prevent corrosion.</p> |  |

Post Mount and Control Cover Installation

A post mount and control cover are pre-attached to the torch for use with the optional post (3" round lamp post) or pier mount. If using the wall mount, use the control cover included with the wall mount kit.

- (a) Detach the control cover from the torch assembly. Keep the two thumb screws used to attach the cover.

- (b) Slide the control cover over the post.

HINT: Use low-tack tape to protect the post from scratches.

NOTE: When installing the post, make sure the post is positioned with the mounting holes 45° offset from the front. The post mount has obround holes that allow 20° of rotation (10° in each direction).

- (c) Attach the gas and electrical lines.

WARNING: Take care when handling the torch assembly to not damage the gas or electrical line.

- (d) Attach the torch to the post using the included ¼-20 screws.

- (e) Attach the control cover to the torch with the two thumb screws.

! The safety label slides into place between the control cover and the torch body.

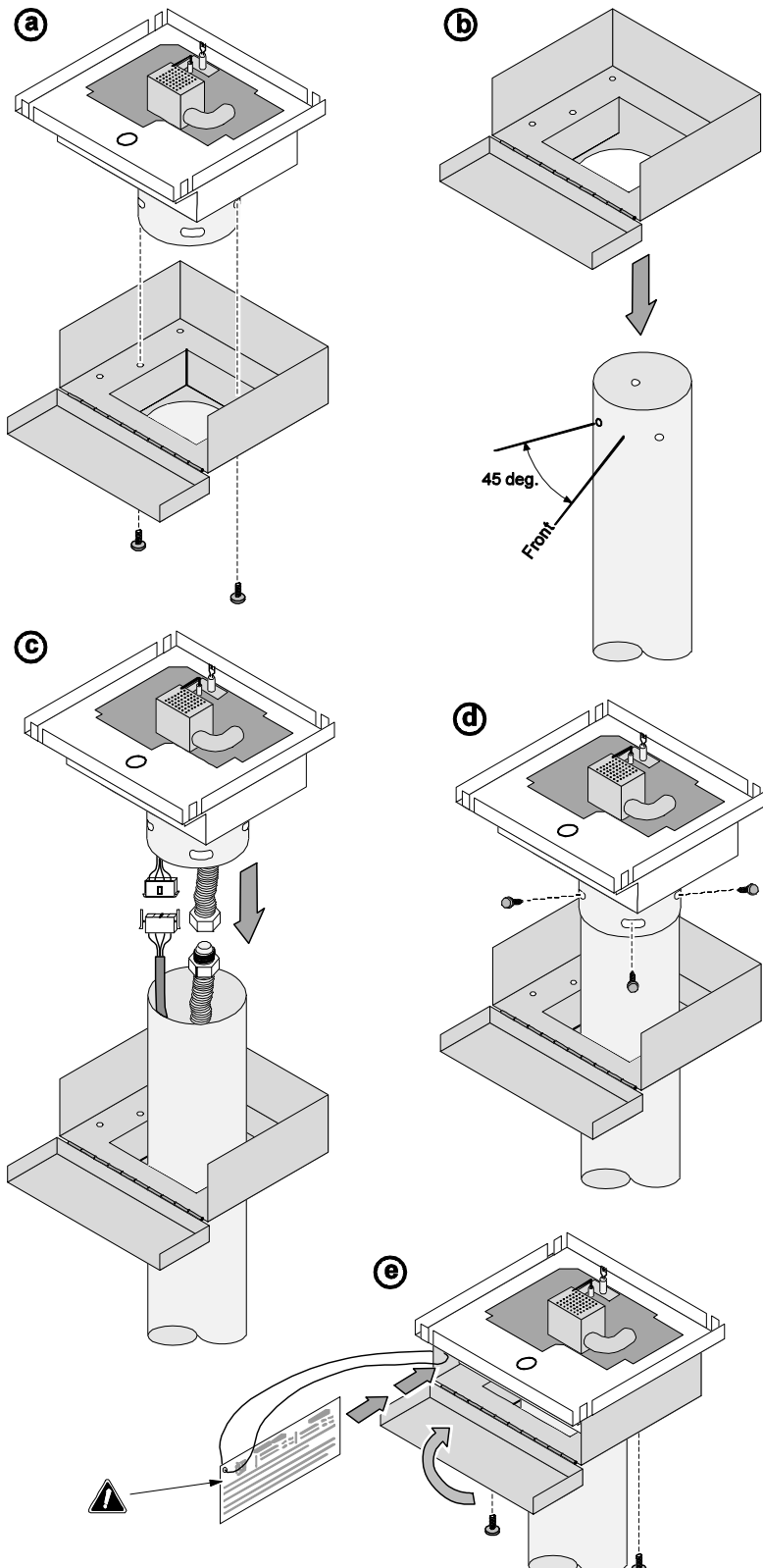

Torch Assembly

- (a) Place the burner top over the main assembly. Make sure the burner top is fully seated.

! Make sure the hotwire element lines up with the hole on the burner top.

- (b) The support bars are shipped with two screws pre-installed. Remove the screws from the support bars and attach the four bars to the main assembly. Make sure the bars are properly aligned (square to the edge of the main assembly).

- (c) Attach the top plate.

NOTE: If using the optional rain cap, you may wish to install it now before the glass is installed (see page 13).

- (d) Slide one piece of glass into place until it contacts the support bar.

! Make sure the teflon tape is at the top of the glass with the wrap-around edge facing inwards.

HINT: Make sure the glass is clean before installing and handle with soft gloves or other non-marking material (e.g. paper towel).

- (e) Use a 5/32" hex wrench to tighten the glass support bolt.

! Tighten the bolt only enough to hold the glass in place – **overtightening may break the glass.**

Repeat steps "d" and "e" for the other three pieces of glass.

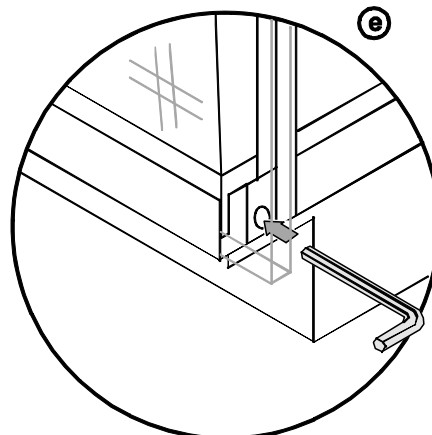
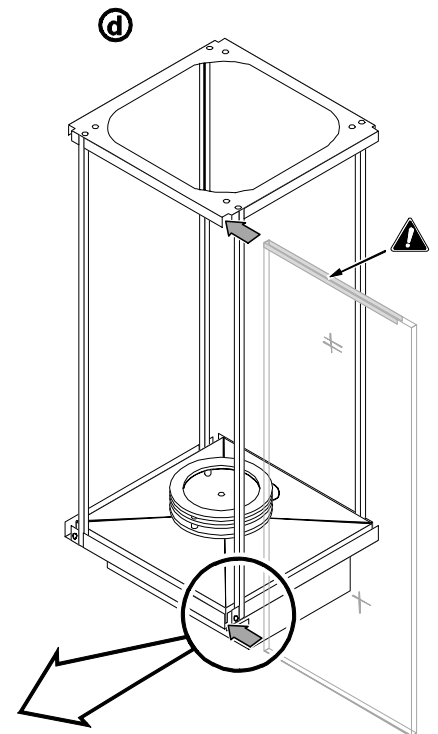
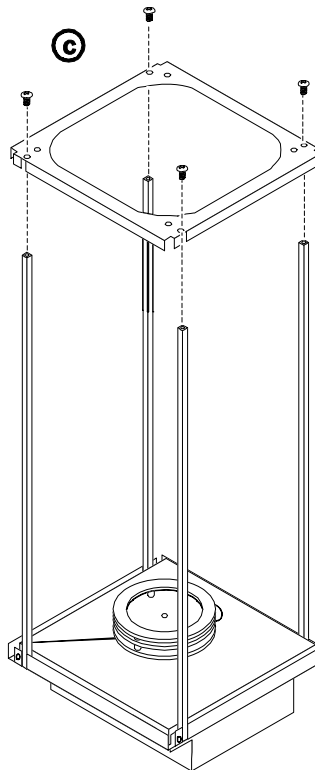
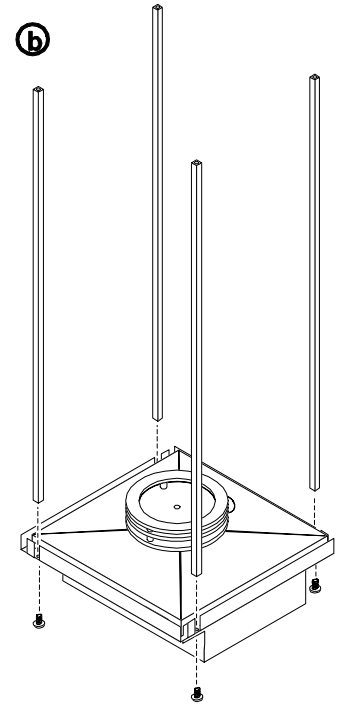
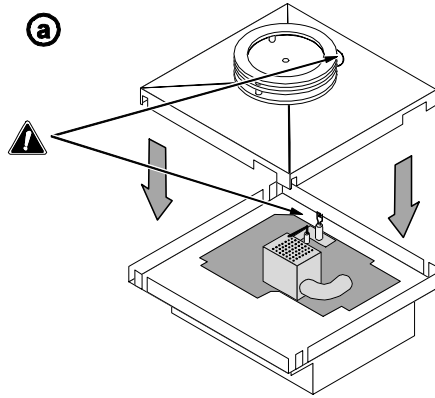

Optional Rain Cap

The optional rain cap may be installed to suit the installation location. If the torch is located in an area where rain or plant debris is prevalent, you may wish to permanently mount the rain cap to the torch with the included nuts.

Place the rain cap on top of the torch so the four studs insert through the top plate. With one or two pieces of glass removed, secure the rain cap using the included nuts (shipped pre-attached to the rain cap).

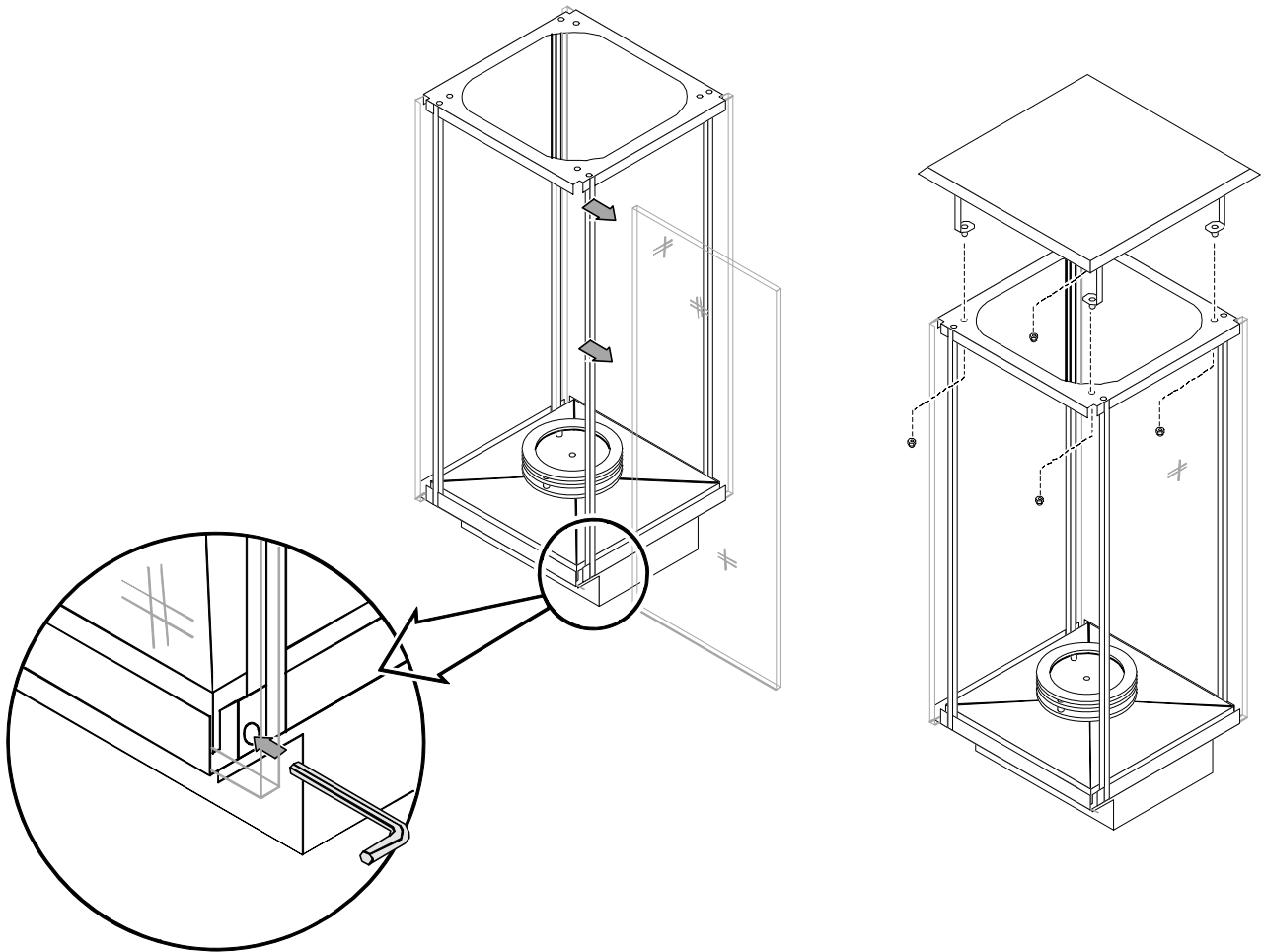

WARNING: Do not use the torch cover (sku 94800867) with electronic ignition torch. The cover will combust if in place while the torch is turned on, creating a severe safety hazard.

Wall Mount Kit

An optional wall mount kit is available for mounting the tempest torch to a wall (or other horizontal structure). See the wall mount kit for full set of assembly and installation instructions.

NOTE: The control cover and post mount are not used with the wall mount kit.

HINT: Provide approximately 18" to 24" of slack on the control wire from the point it enters the wall mount. This allows for the wall mount to be installed with sufficient wire length.

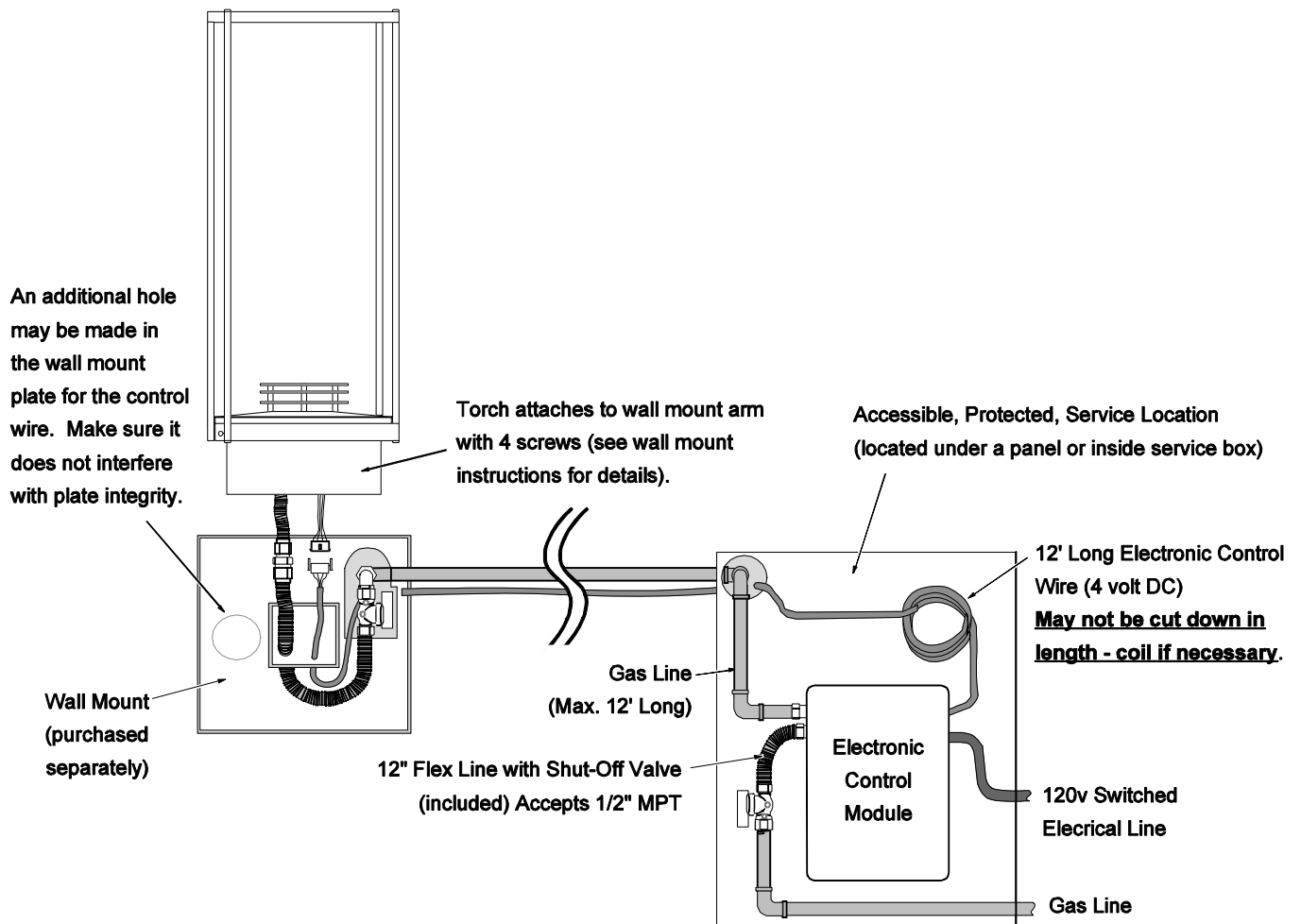

Post or Pier Mounted Torch

The tempest torch may be mounted to a 3" diameter post using the included post mount. This post may be surface mounted on a deck or similar platform with the optional post base kit. If the post is placed in a remote location, it may be sunk into the ground using concrete or other suitable means. See the post or post base kit for assembly and installation instructions.

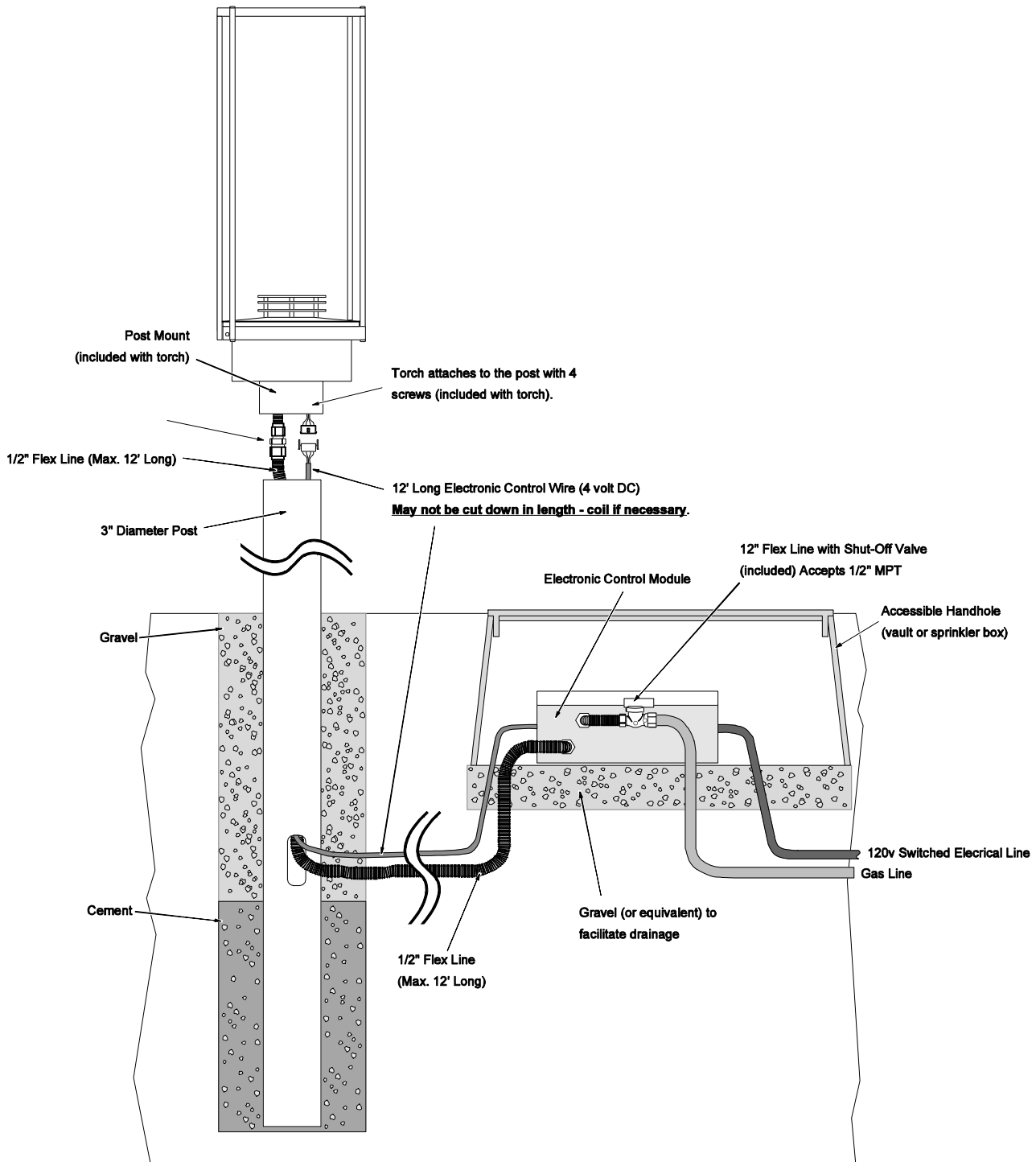

Before You Begin

- ! Read this entire manual before you use your new torch, especially the section "Safety Precautions" on page 4. Failure to follow the instructions may result in property damage, bodily injury, or even death.
- ! Remove any cover from the torch prior to operation (the optional stainless-steel rain cap may be left in place).
- ! Inspect the torch to make sure it is free of debris or objects that may have fallen into the torch prior to operation.
- ! Inspect the torch, burner, and supply lines for any damage prior to operation. The burner must be replaced prior to the appliance being put into operation if it is evident that the burner is damaged. Use only Travis Industries replacement burners.
- ! It may be difficult to see the burner operating in direct sunlight.
- ! **WARNING: Do not use the torch cover** (sku 94800867) with electronic ignition torch. The cover will combust if in place while the torch is turned on, creating a severe safety hazard.

Operating Instructions

WARNING: This gas torch is automated, it runs off of an electric ignition system and may not be lit with a lighter or matches.

How your torch works

Ignition

When you switch the torch on, electrical power is supplied to the control module, starting the ignition sequence. During ignition the hotwire will glow red (the glow wire is visible behind the burner rings on the torch). Gas is then turned on to the torch. The torch will ignite and the flame sensor will signal the control module that the torch is lit and the hotwire will then turn off.

NOTE: In rare cases, the torch will fail to light. In these cases the torch will wait 15 seconds, then re-start the 9-second ignition sequence. The control module will try to re-start the torch a total of 3 times. If it fails to light after three tries, the torch will then shut-off. To re-start, turn the switch off, wait 3 seconds, then turn the switch on.

Torch in Operation

The torch, once lit, will stay lit until power to the torch is turned off. If gas flow is interrupted, or if wind blows-out the flame, the torch will start the ignition sequence.

Multiple Torches

Each torch operates independently. If you install multiple torches on one power switch and need to turn one of the torches off, shut the gas off to the specific torch. Shutting one torch off will not affect the others.

Safety Circuit

Each torch has a built in safety circuit that only allows gas to flow during the ignition sequence and when the torch is lit. This prevents gas build-up. The safety circuit relies upon a flame sensor to keep the gas valve open. If the flame goes out the control module will shut the gas off then try to relight the torch. Your torch can not be operated manually, if a problem persists consult the trouble shooting guide (pg 20) and call a qualified service technician if needed.

Torch Operation Options

Your torch is operated from an electrical circuit similar to an exterior light. You can set up one or many torches on a single power supply. Torches may be set up and operated from any system that a house or exterior light could be operated from. Some examples are:

- Wall switch
- Timer
- Smart home control system
- Remote control

Maintaining Your Torch

! **Failure to inspect and maintain may lead to malfunctioning of the appliance and potentially dangerous situations.**

- Inspect Torch prior to each use.
- Keep torch clean, remove any debris that collects in or on Torch. Inspect for spiders and insects, they may clog burner ports or air inlets and need be removed before using.
- Have the appliance inspected by a qualified service technician annually.
- The stainless steel burner top will discolor – this is normal.

Your Tempest torch is designed to be cleaned and maintained easily. The most common maintenance that your torch will require is glass cleaning. This is done by loosening the glass retaining screws. Each piece of glass will have its own retainer. Hold the glass by the exposed edge and slide horizontally out of its tracks, the glass should slide easily if its retainer screw is loose.

Clean with glass cleaner or warm soapy water. The glass on your Tempest is tempered and designed for safety. If it breaks it will shatter into small square pieces similar to a car windshield. It is special glass and if you break one or need to replace a piece use only 3/16" thick tempered glass supplied by your Tempest Torch dealer.

To inspect for or clean debris out of the inside of your torch remove one piece of glass. This will provide access to the inside of your torch. Once your glass piece is out remove the pyramid shaped piece with the rings on the top by lifting it straight up, once you are clear of the burner elements turn it sideways and remove through the glass opening. This will provide you a clear view of all the torch components, visually check for and remove all foreign objects, vegetation, bugs, debris. When reassembling make sure you orient the Pyramid plate correctly, the burner elements that stick up through this plate are delicate. Once oriented, slide the plate straight down onto the burner assembly making sure the edges are seated all the way down.

Winterizing The Torch.

In areas where the torch may not be used in winter, or for an extended period of time, you may wish to shut off gas to the torch. This will insure the torch is not accidentally turned on or started with debris or snow inside the torch.

WARNING: Do not use the torch cover (sku 94800867) with electronic ignition torch. The cover will combust if in place while the torch is turned on, creating a severe safety hazard.

Replacement Parts

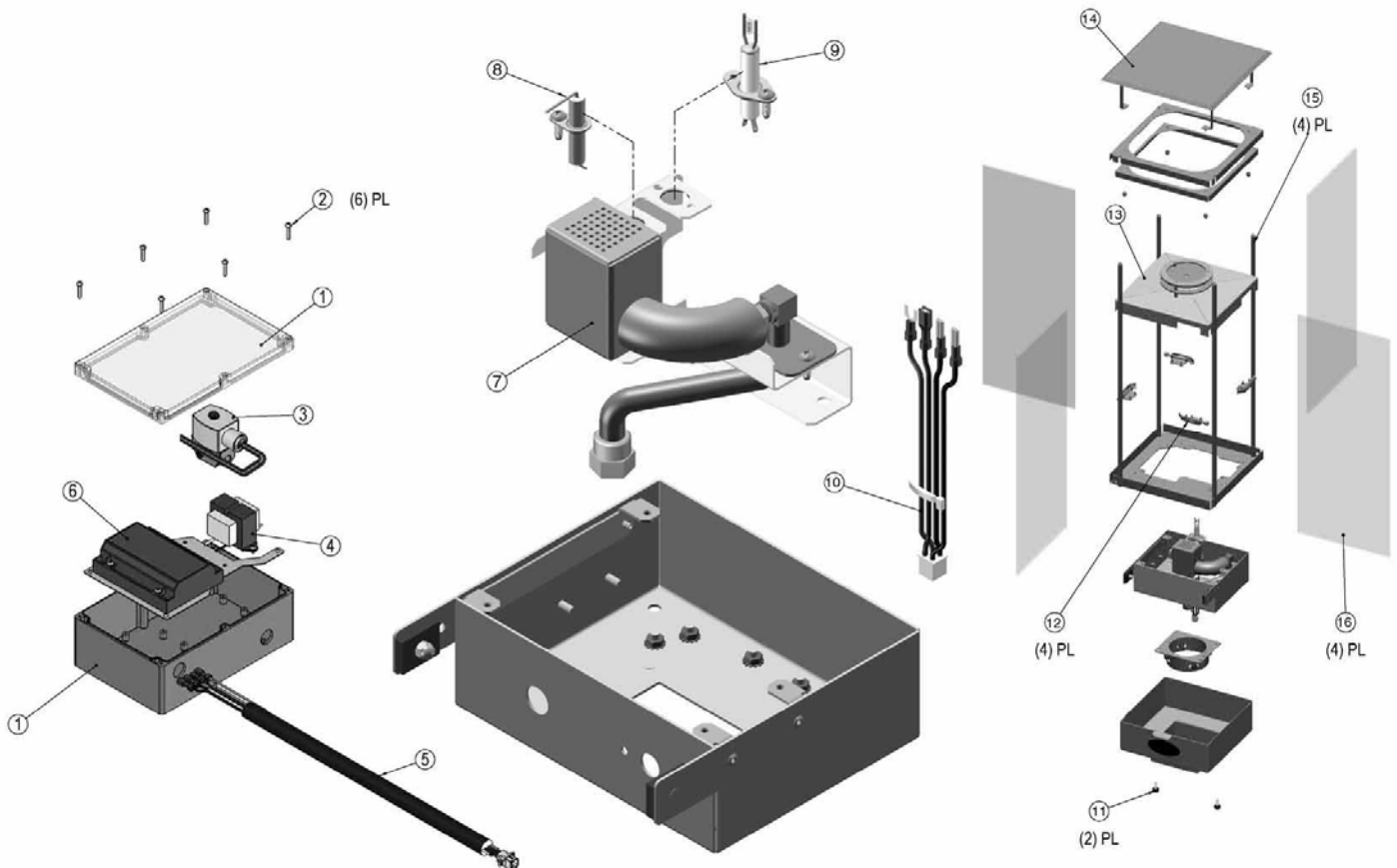

| Part # | Description | Diagram # |
|-----------|---------------------------------|-----------|
| 250-01798 | WATERTIGHT ENCLOSURE BOX ONLY | 1 |
| 250-01800 | SCW, PHMS M4 x 20mm PK OF 6# | 2 |
| 250-01794 | VALVE ASSY, TEMPEST ELEC NG/LP | 3 |
| 250-01792 | TRANSFORMER, TEMPEST EL LP/NG | 4 |
| 250-01793 | WIRE HRNS, MAIN - CONTROL BOX | 5 |
| 250-01795 | CONTROL MODULE, TEMPEST | 6 |
| 250-01783 | BRN SYSTEM ASSY, TMP(EI) LP | 7 |
| 250-01784 | BRN SYSTEM ASSY, TMP(EI) NG | 7 |
| 250-01785 | FLAME SENSOR, TEMPEST | 8 |
| 250-01786 | ELECTRODE (HOTWIRE), TEMPEST | 9 |
| 250-01780 | WIRE HRNS, MAIN-HEAD(TEMP) EL | 10 |
| 250-01799 | THUMB SCREW, TEMPEST TORCH | 11 |
| 250-01445 | GLASS RETAINER (TEMPEST) 1 EACH | 12 |
| 250-01790 | FLAME SPREADER w/PYRMD- NG | 13 |
| 250-01791 | FLAME SPREADER w/PYRMD - LP | 13 |
| 250-01256 | RAIN CAP ASS'Y, TEMPEST | 14 |
| 250-01257 | VERTICLE ROD w/SCRWS, TEMPEST | 15 |
| 250-01251 | GLASS - TEMPEST | 16 |
| 250-01787 | STOVE PACK, TEMPEST ELCTRC IGN | |
| 250-01789 | BALL VALVE, (SHUT-OFF) TEMPEST | |
| 250-01796 | CORD GRIP, WIRE HARNESS | |
| 250-01797 | CORD GRIP PWR IN TEMP ELEC | |
| 250-01909 | FUSE, BLADE -FAST ACTING -5PK | |

Replacement parts can be obtained from your Tempest torch retailer (see www.tempesttorch.com).

Troubleshooting Table

| Problem: | Possible Cause: | Don't Call for Service Until You: |
|--|--|--|
| Torch Does Not Light and Hotwire does not Glow Red | Electrical Power Off | Verify power is on and check circuit breaker or GFCI. |
| Torch Does Not Light and Hotwire Glows Red | Gas is Off | Turn Gas On (check shut-off valve) |
| Torch Lights During Ignition Sequence then Goes Out During Normal Operation | Dirty Air Channel or Burner | Remove glass and clean soot from pyramid plate, burner, and any air channels. If problem persists, contact dealer for service. |
| Flames are too short (under 6") | The gas supply pressure to the appliance is too low. | Depleted LP cylinder. Gas supply lines or gas regulators do not have enough capacity. This maybe due to other appliances in the house using up the available capacity, e.g. pool heaters, furnaces, hot water tanks, etc. |
| Flames are not Spiral | Torch was just turned on | It takes 5 to 10 minutes for the torch to start up and the flame to form a spiral. |
| | Windy Condition | Wind will influence the flame shape |
| Glass is Sooting | Burner or burner orifice may be dirty or blocked | Contact your dealer for details on removing any debris (spider webs, etc.) from the burner and orifice area. |
| | Windy Condition | Wind will influence the flame quality and, if persistent, may lead to sooting on the glass. |
| Torch makes Clicking Sounds | Glass is moving inside the glass frame and the stainless steel parts are expanding and contracting with heat | THIS IS NORMAL |

To register your TRAVIS INDUSTRIES, INC. 1 Year Limited Warranty, complete the enclosed Warranty card and mail it within **ten (10)** days of the appliance purchase date to: TRAVIS INDUSTRIES, INC., 4800 Harbour Pointe Blvd. SW, Mukilteo, WA 98275. TRAVIS INDUSTRIES, INC. warrants this gas appliance (appliance is defined as the equipment manufactured by Travis Industries, Inc.) to be defect-free in material and workmanship to the original purchaser from the date of purchase as follows:

Check with your dealer in advance for any costs to you when arranging a warranty call. Mileage or service charges are not covered by this warranty. This charge can vary from store to store.

90 Day Coverage: PARTS & LABOR

Burner Assembly:

Burner, Venturi, Flame Spreader, Orifice, Gas valve

Glass:

Glass (breakage from thermal shock only)

Accessories:

Portable base (including post and tank cover), wall mount bracket, in-ground post, and pier post

One-Way Freight Allowance:

One-way freight allowance on pre-authorized repair done at factory is covered.

Electrical Components:

Flame Sensor, Transformer, Wire Harness, Control Module, Igniter

Exclusions: *Paint and Finish*

Year 1 Coverage: PARTS & LABOR

Burner Assembly:

Burner, Venturi, Flame Spreader, Orifice, Gas valve

Glass:

Glass (breakage from thermal shock only)

Accessories:

Portable base (including post and tank cover), wall mount bracket, in-ground post, and pier post

One-Way Freight Allowance:

One-way freight allowance on pre-authorized repair done at factory is covered.

Exclusions: *Paint and Finish, Electrical Components*

CONDITIONS & EXCLUSIONS

1. This new gas appliance must be installed by a qualified gas appliance technician. It must be installed, operated, and maintained at all times in accordance with the instructions in the Owner's Manual. Any alteration, willful abuse, accident, neglect, alteration, misapplication or misuse of the product shall nullify this warranty.
2. This warranty is nontransferable, and is made to the ORIGINAL purchaser, provided that the purchase was made through an authorized TRAVIS dealer.
3. Discoloration and some minor expansion, contraction, or movement of certain parts and resulting noise, is normal and not a defect and, therefore, not covered under warranty. The installer must ensure the appliance is burning as per the rating tag at the time of installation. Over-firing (operation above the listed BTU rate) of this appliance can cause serious damage and will nullify this warranty.
4. This warranty does not cover damage to the finish, such as scratches, dents, discoloration, rust or other weather damage, after purchase.
5. Travis Industries will not be responsible for inadequate performance caused by environmental conditions such as nearby trees, buildings, roof tops, wind, hills or mountains or other influences from mechanical systems such as fans, etc.
6. This Warranty is void if:
 - a. The unit has been operated in atmospheres contaminated by chlorine, fluorine or other damaging chemicals.
 - b. The unit is subject to submersion in water.
7. Exclusions to this 1 Year Warranty include: injury, loss of use, damage, failure to function due to accident, negligence, misuse, improper installation, alteration or adjustment of the manufacturer's settings of components, lack of proper and regular maintenance, damage incurred while the appliance is in transit, alteration, or act of God.
8. This 1 Year warranty excludes damage caused by normal wear and tear, such as discoloration. Also excluded is damage to the unit caused by abuse, improper installation, modification of the unit, drilling of the orifices, or the use of fuel other than that for which the unit is configured. Units are shipped for either natural gas or propane. Confirm fuel configuration with your installer.
9. Damage to stainless steel surfaces caused by fingerprints, scratches, melted items, or other external sources left on the stainless steel from the use of cleaners is not covered in this warranty.
10. TRAVIS INDUSTRIES, INC. is free of liability for any damages caused by the appliance, as well as inconvenience expenses and materials. Incidental or consequential damages are not covered by this warranty. In some states, the exclusion of incidental or consequential damage may not apply.
11. This warranty does not cover any loss or damage incurred by the use or removal of any component or apparatus to or from the gas appliance without the express written permission of TRAVIS INDUSTRIES, INC. and bearing a TRAVIS INDUSTRIES, INC. label of approval.
12. Any statement or representation of TRAVIS products and their performance contained in TRAVIS advertising, packaging literature, or printed material is not part of this 1 year warranty.
13. This warranty is automatically voided if the appliance's serial number has been removed or altered in any way.
14. No dealer, distributor, or similar person has the authority to represent or warrant TRAVIS products beyond the terms contained within this warranty. TRAVIS INDUSTRIES, INC. assumes no liability for such warranties or representations.
15. Travis Industries will not cover the cost of the removal or re-installation.
16. If for any reason any section of this warranty is declared invalid, the balance of the warranty remains in effect and all other clauses shall remain in effect.
17. THIS 1 YEAR WARRANTY IS THE ONLY WARRANTY SUPPLIED BY TRAVIS INDUSTRIES, INC., THE MANUFACTURER OF THE APPLIANCE. ALL OTHER WARRANTIES, WHETHER EXPRESS OR IMPLIED, ARE HEREBY EXPRESSLY DISCLAIMED AND PURCHASER'S RECOURSE IS EXPRESSLY LIMITED TO THE WARRANTIES SET FORTH HEREIN.

IF WARRANTY SERVICE IS NEEDED:

1. If you discover a problem that you believe is covered by this warranty, you **MUST REPORT** it to your TRAVIS dealer **WITHIN 30 DAYS**, giving them proof of purchase, the purchase date, and the model name and serial number.
2. Travis Industries has the option of either repairing or replacing the defective component.
3. If your dealer is unable to repair your appliance's defect, he may process a warranty claim through TRAVIS INDUSTRIES, INC., including the name of the dealership where you purchased the appliance, a copy of your receipt showing the date of the appliance's purchase, and the serial number on your appliance. At that time, you may be asked to ship your appliance, freight charges prepaid, to TRAVIS INDUSTRIES, INC. TRAVIS INDUSTRIES, INC., at its option, will repair or replace, free of charge, your TRAVIS appliance if it is found to be defective in material or workmanship within the time frame stated within this 1 year warranty. TRAVIS INDUSTRIES, INC. will return your appliance, freight charges prepaid by TRAVIS INDUSTRIES, INC., to your regional distributor, or dealership.

| | |
|--|----|
| Additional Items Required | 6 |
| Before You Begin | 17 |
| Dimensions | 5 |
| Electrical Connection Requirements..... | 9 |
| Features | 5 |
| Gas Line Connection..... | 9 |
| Gas Line Requirements | 9 |
| Important Registration and Service Information | 2 |
| Installation Options..... | 5 |
| Installation Warnings..... | 6 |
| Listing Details..... | 2 |
| Maintaining Your Torch | 18 |
| Operating Instructions..... | 17 |
| Optional Rain Cap..... | 14 |
| Overview | 2 |
| Packing List..... | 6 |
| Placement Requirements..... | 8 |
| Post Mount and Control Cover Installation | 12 |
| Post or Pier Mounted Torch | 16 |
| Recommended Order of Installation | 7 |
| Replacement Parts..... | 19 |
| Safety Precautions | 4 |
| Specifications | 5 |
| Steps for Connecting the Electrical Line | 11 |
| Torch Assembly | 13 |
| Troubleshooting Table | 20 |
| Wall Mount Kit..... | 15 |
| Warranty..... | 21 |
| Winterizing The Torch..... | 18 |
| Wiring Diagram | 9 |
| Wiring Multiple Torches to One Switch..... | 10 |